

Sustainability-Orienting Design Support for Farm Machinery Design

A thesis submitted in partial fulfillment of the
requirements for the Degree of
Doctor of Philosophy

By
Sharmistha Banerjee



Department of Design,
Indian Institute of Technology Guwahati

Assam, India 781039

April 2021

Sustainability-Orienting Design Support for Farm Machinery Design

A thesis submitted in partial fulfillment of the requirements for the Degree of
Doctor of Philosophy

By
Sharmistha Banerjee

Roll No. 136105012

Under the Supervision of
Prof. Ravi Mokashi Punekar



Department of Design,
Indian Institute of Technology Guwahati

Assam, India 781039

April 2021

DECLARATION

It is certified that the work contained in this thesis entitled "Sustainability-Orienting Design Support for Farm Machinery Design". It has been carried out by me, a student in the Department of Design, Indian Institute of Technology Guwahati under the guidance of Prof. Ravi Mokashi Puneekar for the award of Doctor of Philosophy and that this work has not been submitted elsewhere for a degree.

Date: 20th April 2021

Sharmistha Banerjee

Sharmistha Banerjee

Department of Design

Indian Institute of Technology Guwahati

Guwahati 781 039

Assam, India



CERTIFICATE

The research work presented in this thesis entitled “Sustainability-Orienting Design Support for Farm Machinery Design” has been carried out under my supervision and is a bonafide work of Ms. Sharmistha Banerjee. This work submitted for the degree of Doctor of Philosophy is original and has not been submitted for any other degree or diploma to this institute or to any other institute or university. She has also fulfilled all the requirements including mandatory coursework as per the rules and regulations for the award of the degree of Doctor of Philosophy of Indian Institute of Technology Guwahati.

Date: 29.04.2021

Ravi Mokashi Punekar

Ravi Mokashi Punekar

Professor, Department of Design

Indian Institute of Technology Guwahati

Guwahati 781 039

Assam, India

Dedication

My parents who taught and enabled me to look further ahead each day.

My husband who supported me to walk further ahead each day.

And my daughter.



Acknowledgement

At this juncture, where I am on the finish line of my doctoral work, I feel obliged to one and all who became part of this journey. The biggest support in this journey is my supervisor, Prof. Ravi Mokashi Punekar, who constantly encouraged, challenged and supported me to raise the bar. My doctoral committee members, Dr. Sougata Karmarkar, Dr. Debayan Dhar and Dr. Shrikrishna N. Joshi, gave me very insightful feedback and helped me achieve finesse in my research work. Dr. Prasad Bokil, who also was part of my doctoral committee at the beginning of the journey, helped me channelize my thought process during many of our formal and informal interactions.

This thesis would not have been feasible without the support of the iDE-B and CIMMYT team, who were instrumental in the case study, which forms the backbone of the theoretical knowledge generated. I want to express my heartfelt thanks to the iDE-B team comprising Boudewijn Sterk, Conor Riggs, Md. Badrul Alam, Asma Khan, Imran Nizami, Ranjan Das, Samar Singh, Chetan Kannadaka Shivarama, Kevin Robbins, Ahad Abdullah and other support staff for their valuable inputs and support during the project.

I want to express gratitude to the following experts for their valuable inputs during the case study: Engr. Md. Shoeb Hassan, Chief Scientific Officer & Head, FMP Engineering Division, BARI, Gazipur; Engr. Md. Ayub Hossain, Ph.D., Post Doc, FIEB, Principal Scientific Officer, BARI, Gazipur; Engr. Muhammad Arshadul Hoque, Senior Scientific Officer, BARI, Gazipur; Engr. Kowshik Kumar Saha, Scientific Officer, BARI, Gazipur; Timothy J. Krupnik, Ph.D., Cropping Systems Agronomist, CIMMYT; Mahesh Kumar Gathala, Ph.D., Scientist - Cropping Systems Agronomist, CIMMYT; Md. Abdul Momin, Ph.D., Cropping Systems Agronomist, CIMMYT; Md. Shahjahan, Ph.D., Cropping Systems Agronomist, GCAP, (Ex. Seed Specialist, FAO), CIMMYT; Md. Mohi Uddin, Ph.D., Cropping Systems Agronomist, CIMMYT-Bangladesh; Md. Enamul Haque, Ph.D., Adjunct Associate Professor - Murdoch University, Australia & Team Leader, Conservation Agriculture Project, iDE-B; Subrata Kumar Chakrabarty, Program Manager (CSISA-MI), CIMMYT; Md. Shahidull Islam, Technical Officer, Global Conservation Agriculture Program, CIMMYT.

A special thanks to Mr. Oli Hujur of Janata Engineering and his team for explaining and demonstrating the machine and supporting during the mockup and prototyping process and to all the farmers, LSPs, operators and dealers who shared their valuable time and knowledge with us.

Mr. Partha Sarathi helped me in coordinating and conducting the evaluation phase of the research. I am thankful to Mr. Partha and all other students and professionals who participated in the evaluation process. I am thankful to Dr. Zhang Jun, Associate Professor, School of Design, Hunan University for getting me in touch with Chinese participants who helped in the evaluation and validation of the results.

I am deeply grateful to all my friends and colleagues, especially Pankaj Upadhyay, Sheetal Gokhale and Dr. Shakuntala Acharya at IIT Guwahati for their constant support and motivation during the journey.

Sharmistha Banerjee

Abstract

United Nations (UN) Sustainable Development Goals (SDGs) has set zero hunger, food security, and sustainable agriculture as key sustainability goals to be achieved by the global community. To achieve the same, it is critical to look into avenues for advancing agricultural growth while balancing its impact on the environment and the agroecosystem's overall socio-economic context. The agroecosystem consists of physical, social, economic, and political systems. Agricultural machinery (AM) is an essential input in the agroecosystem with a significant influence on the agroecosystem's environmental and socio-economic sustainability. Hence, the design of AM should consider sustainability as the driving factor.

This thesis focuses on sustainable agricultural mechanization (SAM) development for small farms in developing countries. Statistics show that developing countries are dominated by farm holdings less than 2 hectares in size. The sustainability of these farms is crucial for the sustainability of agriculture in these countries. Mechanization of these farms is the need of the day considering the rising cost and shortage of labor. Studies show that mechanization increases farm power availability, cropping intensity, and food grain production while saving time, labor, production costs, post-harvest losses, seeds, and fertilizers. Thus, mechanization offers the possibility of increasing farmers' income. Due to the lack of economies of scale, it is not feasible for these farmers to own AM. Their AM needs are also very different from that of large, heavily mechanized farms. Thus, these small farms need the development of AM that can be hired as per need, i.e., a product-service combination offering. Also, the context demands that the said AM-based product-service system (PSS) offer support infrastructure and product-services (for allied processes) so that the farmers can cost-effectively adopt it. Thus, the context calls for AM and its allied service ecosystem's design as a sustainable PSS (S.PSS).

Several studies on AM using a lifecycle assessment (LCA) approach are available. They compare the environmental effects of AM due to its production, distribution, use, and disposal. Though the environmental dimension is an important pillar to achieve sustainability, the LCA approach can only control the production side. It can help select materials, energy sources, and processes that have a lower environmental impact by improving production technologies, system life, consuming lower resources, reducing transportation impact, producing lesser volumes of waste and toxic wastes, and improving biocompatibility. It uses possible usage scenarios to estimate the environmental impact of the consumption and end-of-life phase. These can be very deviant from the real-life scenario. Hence, it cannot guarantee environmental performance beyond the production phase. LCA tools are suited to compare design alternatives and do not offer much to identify key sustainability issues arising from consumption behavior. Hence, they cannot perform a strategic analysis of consumption behavior and generate design guidelines that bring forth sustainable consumption. It also fails to capture the socio-ethical and economic dimensions of sustainability. Documented evidence connects social and economic unsustainability with the introduction of well-intentioned AM into the agroecosystem in due course of time. Thus, only an LCA approach is insufficient for the design of AM. Shifting the lifecycle design (LCD) approach to design for sustainability (DfS) on all three dimensions implies that a designer's focus has to change from designing only AM to design of AM with its associated service ecosystem. Researchers and the Food and Agricultural Organization (FAO) of the UN have a broad outline for SAM's design following a PSS approach. However, there are no detailed sustainability-oriented design or assessment supports available to aid a designer in the complex challenge.

This thesis presents a framework (D-SAM, Design for Sustainable Agricultural Mechanization) and a set of guidelines (G-SAM, Guidelines for Sustainable Agricultural Mechanization) for the

sustainability-oriented design of SAM along with its associated service ecosystem following an S.PSS design approach. D-SAM helps in

- ♦ strategic analysis, including a sustainability assessment and priority setting,
- ♦ ideation process,
- ♦ design and engineering of the product, service, and system, and
- ♦ the sustainability improvement or worsening assessment of the redesigned SAM offer.

D-SAM is built on top of an existing S.PSS design methodology (MSDS, Methodology for System Design for Sustainability) combined with the merits of a lifecycle-based product design toolkit (ICS toolkit). The framework's sustainability metrics (G-SAM) are developed using a literature review from the design domain, the impact study of AM, and sustainability assessment tools from agriculture. The sustainability assessment tools used from the agriculture domain are indicator-based assessment tools with a wide range of scope definitions for varied target groups, thus having a varied selection of indicators, aggregation, and weighing methods. The indicators from these tools have been regrouped and adapted to suit the context of AM. G-SAM helps in the sustainability assessment of the existing scenario, sustainability priority setting for the design, and the ideation process. It puts forward three perspectives for assessment and design in front of the designer: 1. S.PSS design; 2. Design for a sustainable agricultural outcome; and 3. Environmentally sustainable product design. G-SAM provides open-ended ideation cues to guide, educate, and inform a designer during the design process. The assessment is conducted using rapid sustainability assessment (RSA) indicators. G-SAM integrates the analysis and design ideation phase in its construct as designers perform analysis and ideation simultaneously.

The thesis follows a Design Science Research (DSR) approach. DSR follows the iterative design-and-development process to build a practical intervention for a real-life problem while building theory simultaneously from the learnings. In the thesis, DSR stages of research, analysis, synthesis, and evaluation are iterated twice. The D-SAM framework I is built through literature research and applying the existing methodologies to a case study design of a two wheeled power tiller (2WT)-based bed planter (BP) for Bangladesh. D-SAM framework II and G-SAM are built as a revision of the framework I by using a literature review of indicator-based sustainability assessment tools from varied agricultural domains. It is then evaluated by students and professionals from India and China.

The evaluation of G-SAM showed that it helped strengthen the analysis and design process, reduced factual errors and misunderstandings, and enhanced student designers' learning experience. The professionals also found the guidelines helpful as it broadened their analysis and ideation. It is compatible with little data, as is the case at the fuzzy front-end of the design process. It aids in RSA and the generation of a large pool of design ideas. Interdependencies between indicators and trade-offs become more visible. It was rated useful in field data collection and for conducting participatory design. Transdisciplinary knowledge hybridization is another crucial contribution of G-SAM. It captures systemic knowledge, which aided the designer in better defining goals. Various functions like monitoring, communication, learning, and management can be achieved using G-SAM.

D-SAM and G-SAM are designed for AM consisting of several sub-assemblies and a significant amount of embodied material and energy. The AM should be expensive for individual consumption and have only sparse utilization in individual ownership. A custom-hiring-based consumption in these cases offers a higher usage density and cost-effective consumption. The limitation of D-SAM and G-SAM is the amount of time required to use it. However, considering the depth of analysis and ideation required for the given context, the time requirement is similar to other such tools. In its current form, G-SAM is

more geared towards soil-based agricultural systems and needs further development to accommodate other forms of agriculture like aquaculture, greenhouse farming, and hydroponics.

Keywords: Sustainable agricultural mechanization, sustainable product-service system design, design for sustainability, agricultural machinery design, smallholder farms, developing countries.



Table of Contents

Abstract	i
List of Abbreviations	vi
List of Figures	vii
List of Tables	xi
1. Introduction	1
1.1. Thesis structure.....	4
2. Agricultural mechanization and sustainability	6
2.1. The agricultural scenario in developing countries of the world.....	6
2.2. Farm power and farm mechanization.....	21
2.3. Challenges for smallholders to access mechanization.....	27
2.4. Design challenges of mechanizing smallholder operations.....	27
2.5. Thesis problem definition.....	29
2.6. Research objectives and research questions.....	29
2.7. Scope of the thesis.....	30
3. Research methodology	31
3.1. Design Science Research methodology.....	31
3.2. The rationale for selection of DSR	32
3.3. Research stages of thesis	32
4. Sustainability-orienting design approaches	36
4.1. Evolution of sustainability approaches within the domain of Design.....	36
4.2. Product innovation - life cycle-based assessment and design approach for SAM.....	41
4.3. PSS innovation - Satisfaction-based approach for SAM.....	49
4.4. The rationale for selecting S.PSS as the design for sustainability approach	52
4.5. Sustainability-orienting design approaches from agricultural practices.....	52
4.6. Conclusion	55
5. Case Study: Sustainability-oriented design of a bed planter	56
5.1. About the case study	57
5.2. Assessment of the efficacy and sufficiency of MSDS methodology and ICS toolkit on a SAM case.....	58
5.3. Conclusion	81
6. D-SAM, a sustainability-oriented design methodology for agricultural machinery and its associated service ecosystem design	84
6.1. D-SAM Framework I.....	85
6.2. Refining D-SAM Framework I and development of G-SAM.....	89
6.3. G-SAM.....	101
6.4. D-SAM - A methodology for sustainability-oriented design of agricultural mechanization	123
7. Evaluation and validation	127
7.1. Evaluation criteria.....	127
7.2. Evaluation and validation methodology	130

7.3. Results and analysis	134
7.4. Validation	141
7.5. Conclusion	142
8. Conclusion	143
8.1. Key research findings.....	143
8.2. Thesis contributions	144
8.3. Limitations.....	148
8.4. Future research.....	149
9. Publications	150
Appendix 1.....	151
Appendix 2.....	155
Appendix 3.....	158
Appendix 4.....	162
Appendix 5.....	219
Appendix 6.....	224
Appendix 7.....	231
Appendix 8.....	239
Appendix 9.....	249
10. Bibliography	257

Appendices

Appendix 1: Distribution of smallholdings across the globe

Appendix 2: Research in the context of LCA applied to AM

Appendix 3: S.PSS design supports

Appendix 4: Application of MSDS methodology and ICS toolkit to re-design a 2WT based BP

Appendix 5: Nineteen indicator-based sustainability assessment methods from agriculture

Appendix 6: Literature used to generate the list of critical features, diagnostic criteria, rapid sustainability assessment indicators and design guidelines for the environmental dimension

Appendix 7: Initial categorization of the economic and social dimension's critical features, diagnostic criteria and rapid sustainability assessment indicators

Appendix 8: G-SAM Evaluation strategy 1 data

Appendix 9: G-SAM Evaluation strategy 2 data

List of Abbreviations

Abbreviation	Full-Form
2WT	Two-wheeled power tiller
AM	Agricultural machinery
BARI	Bangladesh Agricultural Research Institute
BP	Bed Planter
CF	Critical Feature
CIMMYT	International Maize and Wheat Improvement Centre
CSISA-MI	Cereal Systems Initiative for South Asia - Mechanization and Irrigation
D-BP	Dongfang 2WT based BP
DC	Diagnostic Criteria
D-SAM	Design for Sustainable Agricultural Mechanization
DfS	Design for Sustainability
DSR	Design Science Research
FAO	Food and Agricultural Organization
FGD	Focus group discussions
G-SAM	Guidelines for Sustainable Agricultural Mechanization
iDE-B	International Development Enterprise Bangladesh
JE	Janata Engineering
LCA	Life Cycle Assessment
LCD	Life Cycle Design
LSP	Local Service Provider
MSDS	Methodology for System Design for Sustainability
PSS	Product-service system
RSA	Rapid Sustainability Assessment
S-BP	Sifang 2WT based BP
S.PSS	Sustainable Product-Service System
SAC	Sustainable Agriculture Criteria
SAM	Sustainable Agricultural Mechanization
G-SAM	Guidelines for Sustainable Agricultural Mechanization
SDGs	Sustainable Development Goals
UN	United Nations
UNEP	United Nations Environment Program

List of Figures

Figure 2.1. FAO's smallholder data portrait - Average farm size (ha). Source: (FAO, 2015).....	9
Figure 2.2. FAO's smallholder data portrait - % of households using motorized equipment. Source: (FAO, 2015).....	10
Figure 2.3. FAO's smallholder data portrait - Value of food production per hectare (const. 2009 Int. \$). Source: (FAO, 2015).....	11
Figure 2.4. FAO's smallholder data portrait - Fertilizer per hectare (kg). Source: (FAO, 2015).....	11
Figure 2.5. FAO's smallholder data portrait - Seeds per hectare (kg). Source: (FAO, 2015).....	12
Figure 2.6. India Input Survey (2011-12) - Farmyard manure (kg) per Ha. Source - (Agriculture Census Division, 2011-12)	12
Figure 2.7. India Input Survey (2011-12) - Fertilizer (kg) per Ha. Source - (Agriculture Census Division, 2011-12)	13
Figure 2.8. Family labor-days supplied on-farm over a day (person-days) per hectare. Source: (FAO, 2015).....	14
Figure 2.9. Estimated yield gaps for major crops (cereals, roots and tubers, pulses, sugar crops, oil crops, and vegetables), by region, 2005. Source - (FAO, 2015).....	14
Figure 2.10. Hired Labor vs Family Labor -days supplied over a day (person-days) per hectare. Source: (FAO, 2015).....	15
Figure 2.11. Relationship between productivity and family workers (Author's calculation using data from Source: (FAO, 2015)).	15
Figure 2.12. Proportion of labor in all agricultural activities that are supplied by women. Source - (FAO, 2011).....	16
Figure 2.13. Mechanical equipment use by female- and male-headed households. Source - (FAO, 2011)	16
Figure 2.14. Years of education of the household head. (FAO, 2015).....	18
Figure 2.15. % of expenditure for inputs on the value of production. (FAO, 2015).....	19
Figure 2.16. % of credit beneficiary households. Indian data - (Agriculture Census Division, 2011-12), Other data - (FAO, 2015).....	19
Figure 2.17. % of agricultural production sold - (FAO, 2015).....	20
Figure 3.1. Framework and Context of DSR as represented by (Venable, 2006).....	31
Figure 3.2. Diagrammatic representation of the research stages of the thesis.....	35
Figure 4.1. Evolution of DfS approach.....	39
Figure 4.2. ICS toolkit screenshot showcasing a sample screen demonstrating how to evaluate and identify environmental concerns in existing products.	48
Figure 4.3. ICS toolkit screenshot showcasing design cues for ideation on the parameter <i>use extension/intensification</i>	48
Figure 4.4. ICS toolkit screenshot showcasing " <i>simplified evaluation</i> " of new concept vs. existing product.	49
Figure 4.5. ICS toolkit screenshot showcasing a visual representation of " <i>simplified evaluation</i> " of new concept vs. existing product using a radar diagram.....	49
Figure 4.6. Analysis of the nature of S.PSS supports that deals with the proposal of a design framework, methodology, guidelines, or tool.....	50
Figure 4.7. Analysis of the target sector for which the S.PSS support is developed.....	51
Figure 5.1. A BARI designed BP, reverse-engineered by Mr. Oli Hujjur of JE.....	57
Figure 5.2. Beds and furrows built by the redesigned BP.	57
Figure 5.3. BP parts and their functions.....	58
Figure 5.4. The expert and grassroots stakeholders who participated in the project data collection. ...	59
Figure 5.5. The flowchart shows the MSDS stages and processes, gaps, and the redesigned sustainability-oriented design approach for SAM achieved by filling the gaps. (adapted from published paper (Banerjee and Punekar, 2020))	61

Figure 5.6. Market definition of the BP PSS co-designed by all stakeholders.	64
Figure 5.7. Sample environmental sustainability analysis and priority setting using the ICS toolkit. ..	65
Figure 5.8. Socio-ethical sustainability analysis and priority setting using the SDO toolkit - checklist existing system.	66
Figure 5.9. Vertical and horizontal systems for the case.	67
Figure 5.10. Identification of pathways to navigate through short-term and long-term viable sustainability objectives.	67
Figure 5.11. Redesigned Stage 1: Strategic Analysis.	70
Figure 5.12. Generating sustainability-oriented ideas using the SDO toolkit - orient the concept.	71
Figure 5.13. Generating sustainability-oriented ideas using the ICS toolkit – eco-ideas board (a sample).	72
Figure 5.14. Sample of idea generation using the SAC ideas board.	72
Figure 5.15. Sample polar ideas.	73
Figure 5.16. PSS concept 1 considering local manufacturing and assembly of BP.	73
Figure 5.17. Sample polarities diagram.	73
Figure 5.18. Redesigned Stage 2: Exploring opportunities.	74
Figure 5.19. Stakeholders of the final PSS.	76
Figure 5.20. Energy flows between the stakeholders in the final PSS.	76
Figure 5.21. Offering diagram for the final PSS.	77
Figure 5.22. Redesigned Stage 3: Designing system concepts.	77
Figure 5.23. Visualizing the expected sustainability improvements alongside the priority for each criterion using radar diagrams for the final PSS.	78
Figure 5.24. BP prototype for testing the functional aspects of the design.	79
Figure 5.25. CAD model of the final BP design.	79
Figure 5.26. ICS Toolkit - simplified evaluation: Radar diagram for environmental dimension	80
Figure 5.27. The new Stage 4: Product designing and engineering.	80
Figure 5.28. Redesigned Stage 5: System designing and engineering.	81
Figure 6.1. D-SAM framework I for a sustainability-oriented design methodology of agricultural mechanization	85
Figure 6.2. The terminology used in the thesis for the hierarchical levels for sustainability assessment and those used by other researchers (adapted from (de Olde, E.M. et al., 2016)).(Bausch et al., 2014; Bélanger et al., 2012; de Boer and Cornelissen, 2002; Guerci et al., 2013; Haas et al., 2000; van Calker et al., 2007).	91
Figure 6.3. G-SAM's indicator formulation process, as derived from MESMIS approach (López-Ridaura, 2002).	92
Figure 6.4. Deriving the framework to develop G-SAM.	93
Figure 6.5. Sample from G-SAM for the environmental dimension.	96
Figure 6.6. Task flow for deriving the environmental dimension of G-SAM.	97
Figure 6.7. Task flow for deriving the economic and social dimension of SAM.	98
Figure 6.8. A sample of the initial critical features, diagnostic and sub-diagnostic criteria, and RSA indicators drawn and grouped into categories.	99
Figure 6.9. Snapshot of G-SAM and flowchart for using it.	101
Figure 6.10. Structure of G-SAM.	102
Figure 6.11. D-SAM - A methodology for sustainability-oriented design of agricultural mechanization	124
Figure 7.1. WM group's feature segregation into three dimensions of sustainability.	134
Figure 7.2. TS groups' rating method categorizes design ideas on the degree of fulfillment of sustainability criteria on each dimension.	135
Figure A4. 1. Strategic analysis – (1.1) Project promoter analysis and definition of intervention context, (1.2) Reference context analysis. Source: (Vezzoli et al., 2014).	162

Figure A4. 2. System Map of Stakeholders.....	163
Figure A4. 3. System Map of Energy Flows between Stakeholders.....	165
Figure A4. 4. Shows the difficulty of comprehending the number of possible combinations for setting the plowing depth of the rotary blades (1) and, based on that, adjusting seedbox box inclination (2). Then the chain tensions need to be adjusted appropriately (3).....	166
Figure A4. 5. The bed shaper cone can be set for different bed sizes.	166
Figure A4. 6. Depending on plowing depth, the furrow opener depth hole needs to be selected.....	166
Figure A4. 7. The furrow opener can be set anywhere in the given slot.....	166
Figure A4. 8. Counterweight in the front to ease lifting the BP (Source: CIMMYT).	166
Figure A4. 9. Turning BP at the end of one line on the field.....	167
Figure A4. 10. Tons of adjustments and awkward postures needed to achieve the same.	168
Figure A4. 11. A section of the means-end analysis.....	171
Figure A4. 12. Functions are mapped according to the six types of values listed in the means-end analysis.....	171
Figure A4. 13. Strategic analysis – (1.3) Product analysis	173
Figure A4. 14. 180° Apart rotary blades arrangement on the shaft.....	174
Figure A4. 15. 120° Apart rotary blades arrangement on the shaft.....	174
Figure A4. 16. 1: Large rotary blades; 2: Small rotary blades; 3: Tip to tip distance between the blades = cutting width of the blades.....	174
Figure A4. 17. 4: The larger blades tend to bend or break at this point.	174
Figure A4. 18. BARI recommended bed dimensions.....	175
Figure A4. 19. Scrapper.....	175
Figure A4. 20. Scrapper fixed to the BP.	176
Figure A4. 21. Bed Shaper (Label 5).	176
Figure A4. 22. 6 - Seed metering plate 7 - Seed metering plate holder 8 - Seed dispensing from the seedbox occurs from this opening.....	177
Figure A4. 23. Deformed delivery tube.	177
Figure A4. 24. Chain sprocket tension adjustment mechanism for seed meter.	177
Figure A4. 25. Seed from chamber 1 to 2 is supposed to be manually transferred. Chamber 1 acts as the storage, while chamber 2 is meant for metering and dispensing.....	177
Figure A4. 26. Strategic analysis – (1.4) System carrying structure analysis. Source: (Vezzoli et al., 2014).	180
Figure A4. 27. Types of rotary blades.	180
Figure A4. 28. The large and small blade, used in the current BP.	180
Figure A4. 29. General types of precision seed metering devices.	181
Figure A4. 30. Types of plate seed meters.	181
Figure A4. 31. General types of mass flow seed metering devices.	181
Figure A4. 32. Common types of furrow opening devices.	181
Figure A4. 33. J-type and Gamma-type flail blades used in Happy Seeder. Source - (Jat et al., 2013).182	182
Figure A4. 34. Flails and flail shaft. Source - (Jat et al., 2013)	182
Figure A4. 35. Strategic analysis – (1.5) Analysis of cases of excellence for sustainability. Source: (Vezzoli et al., 2014).	184
Figure A4. 36. Strategic analysis – (1.6) Analyze sustainability & determine priorities for design intervention in view of sustainability. Source: (Vezzoli et al., 2014).	184
Figure A4. 37. Exploring opportunities – (2.1) Generating sustainability-oriented ideas, (2.2) Outline a design-oriented sustainability scenario. Source: (Vezzoli et al., 2014).	193
Figure A4. 38. Sample polarities ideas.....	207
Figure A4. 39. PSS concept 2.	207
Figure A4. 40. PSS concept 3.	208
Figure A4. 41. PSS concept 4.	208

Figure A4. 42. Designing system concepts - (3.1) Selecting clusters and single ideas, (3.2) Developing system concepts, (3.3) Environmental, socio-ethical and economic sustainability. Source: (Vezzoli et al., 2014).....210

Figure A4. 43. Product designing and engineering - (4.1) designing and engineering the product concept and (4.2) environmental, socio – ethical, and economic assessment.211

Figure A4. 44. BP parts.....212

Figure A4. 45. System designing and engineering - (5.1) Detailed system design, (5.2) Environmental, socio-ethical, and economic assessment. Source: (Vezzoli et al., 2014).215



List of Tables

Table 1.1. Dimensions and levels for assessing agricultural sustainability in the thesis. Source - (Hayati et al., 2010; Zhen and Routray, 2003)	2
Table 2.1. Distribution of smallholdings across the globe (Lowder et al., 2016).	7
Table 2.2. Estimated number of operational holdings by educational status, an all India summary (Agriculture Census Division, 2011-12).....	17
Table 2.3. Distribution of Operational Holder (%) in different Age Groups with Average Age (years) (Agriculture Census Division, 2011-12).....	18
Table 2.4. Estimated number of AM used by operational holding as on 15 th October 2001 by size groups in India (Agricultural Census, Input Survey, 2001-02).....	21
Table 3.1. Elaboration of the DSR process steps (Geerts, 2011; Peffers et al., 2007).....	32
Table 4.1. Sustainability-orienting design approaches classified into innovation levels. Source - (Ceschin and Gaziulusoy, 2016).....	40
Table 4.2. List of LCA and LCD tools (adapted from (Rossi et al., 2016))......	42
Table 4.3. Categorizing the literature based on the aim of the study.	45
Table 4.4. Categorizing the literature based on geography under investigation and farm size.	45
Table 4.5. Literature review: key concepts from existing sustainability-oriented analysis and design guidelines for AM. (from published paper (Banerjee and Punekar, 2020)).....	54
Table 5.1. Summary of the data collection methodology, the stakeholders involved, and the advantages and challenges faced.	59
Table 5.2. Processes in Stage 1: Strategic Analysis, results of using the processes and tools in it, gaps identified and proposed addition.....	62
Table 5.3. Sustainable Agriculture Criteria (SAC) checklist	68
Table 5.4. Summary of priorities set for the project.	69
Table 5.5. Processes in Stage 2: Exploring opportunities, results of using the processes and tools in it, gaps identified, and proposed addition.	70
Table 5.6. Processes in Stage 3: Designing system concepts, results of using the processes and tools in it, gaps identified, and proposed addition.	74
Table 5.7. Processes in Stage 4: Product designing and engineering, results of using the processes and tools in it, gaps identified and proposed addition.	78
Table 5.8. Processes in Stage 5: System designing and engineering, results of using the processes and tools in it, gaps identified and proposed addition.	80
Table 6.1. A conceptual framework for a sustainability-oriented design methodology of agricultural mechanization.	86
Table 6.2. Indicator-based sustainability assessment methods from agriculture	90
Table 6.3. Framework to develop G-SAM.....	93
Table 6.4. Categorization of the economic and social dimension critical features at three levels: system, service, and product.	99
Table 6.5. G-SAM – Environmental Dimension.....	103
Table 6.6. G-SAM – Economic Dimension.....	111
Table 6.7. G-SAM – Social Dimension.....	116
Table 6.8. SAM design methodology – SAM Framework.....	124
Table 7.1. Critical success factors for the implementation of integrated sustainability assessment tools adapted from de Mey et al. (2011) and additions from other authors who have designed assessment and design supports for DfS in the context of S.PSS.....	129
Table 7.2. Counts of the variables from the analysis and ideation report for both problem statements and phases of the experiment.	136
Table 7.3. Results of the Independent-Samples T-Test.	136

Table 7.4. Results of the Paired-Samples T-Test (With all the data combined irrespective of problem statement group).....	137
Table 7.5. Results of the Paired-Samples T-Test (For the problem statement group WM).....	137
Table 7.6. Results of the Paired-Samples T-Test (For the problem statement group TS).....	138
Table A1. 1. Distribution of smallholdings across the globe (adapted from (Lowder et al., 2016)).	151
Table A2. 1. Categorizing the literature based on aim of the study.....	155
Table A2. 2. Categorizing the literature based on geography under investigation and farm size.	156
Table A3. 1. S.PSS research that deals with the proposal of a design framework, methodology, guidelines, or tool.	158
Table A4. 1. Seed rate, seed spacing, and seed depth for various crops per BARI recommendation. .	176
Table A4. 2. Fertilizer (basal quantities) recommendations from BARI.....	178
Table A4. 3. Analysis of existing products using the ICS toolkit on the environmental dimension and defining the product design priorities.	178
Table A4. 4. SDO Toolkit Checklist - Existing context analysis from an environmental, socio-ethical, and economic perspective and priority setting.	184
Table A4. 5. Case assessment using the SAC checklist.	189
Table A4. 6. Ideas generated by all stakeholders using the SDO toolkit - orient the concept on all three dimensions of sustainability.....	193
Table A4. 7. Idea generation using ICS toolkit ideas board.	196
Table A4. 8. Ideas generated using the SAC ideas board.....	202
Table A4. 9. Other ideas generated from the engineering, ergonomics and human-centered requirements identified during research and not mentioned in Table A4. 7 above.....	204
Table A4. 10. The key features in BP design that can bring forth the environmental sustainability improvements.	213
Table A4. 11. The key features in the PSS design that can bring forth the sustainability improvements.	215
Table A5. 1. Comparison of nineteen indicator-based sustainability assessment methods from agriculture based on their aim, target group, and sustainable agriculture definition.	219
Table A7. 1. Initial categorization of the economic dimension's critical features, diagnostic criteria and rapid sustainability assessment indicators from agriculture domain.	231
Table A7. 2. Initial categorization of the social dimension's critical features, diagnostic criteria, and rapid sustainability assessment indicators from agriculture domain.	235
Table A8. 1. Participant details	240
Table A8. 2. Phase 1: Results of designing for SAM without any guidelines.....	240
Table A8. 3. Phase 2: Results of designing SAM with G-SAM.	241
Table A8. 4. Summary of evaluation of the G-SAM toolkit by the student designers.	242
Table A8. 5. Evaluation sheet raw data.....	242
Table A9. 1. G-SAM evaluation sheet raw data.....	250

1. Introduction

The Population Division of the Department of Economic and Social Affairs of the UN Secretariat (2019) projected that the global population would increase from the 2019 level of 7.7 billion to 9.7 billion by 2050 and 10.9 billion by 2100. Thus, producing and supplying quality, safe, and nutritious food in adequate quantities to this growing population will be a challenge for us. Scientific and engineering advancement has led to intensification in agricultural production and improved productivity. However, the intensification has also drastically increased the ecological footprint of agriculture due to intensified use of inputs like fertilizers, pesticides, water, and land (Bockstaller et al., 2009). Data shows that the global greenhouse gas emissions in agriculture have increased from 4.6 million gigagrams of CO₂ equivalents in 1995 to 5.3 million gigagrams in 2016. Food production has increased from 77 billion USD to 129 billion USD in the same period. (FAO Statistics, 2018). The Global Assessment of Soil Degradation, commissioned by the UN Environment Program (UNEP), estimated that 22.5% of agricultural land, pastures, forests, and woodland are degraded since the middle of the 20th century (Gibbs and Salmon, 2015). Thus, the need for studying and practicing agricultural sustainability has cropped up. Achieving sustainability in agricultural systems is also key to global sustainable development.

One of the key challenges in the sustainability studies domain is the agreement on the definition of sustainability. For example, Hayati (2017) reports that between 1984 and 2016, 44 definitions of sustainable agriculture can be found in the literature. In the context of agriculture, Zhen and Routray (2003) and Hayati et al. (2010) report that three dimensions and various levels have been used to assess sustainability (Table 1.1). The normative dimension consists of majorly three levels, ecological, economic, and social. The second dimension is spatial, consisting of the levels, local, regional, and national. The third dimension is temporal, defined by the long-term and short-term levels. Hayati (2017) classified these 44 concepts and definitions of sustainable agriculture as catering to the ideas of sustainability as an ideology, a set of strategies, a means for setting goals to achieve, or the ability to continue surviving. However, most of these definitions account for all the three normative sustainability levels (hereafter, referred to as dimensions): environmental, economic, and social. The FAO Council (1989) defined sustainable agriculture as *“the management and conservation of the natural resource base, and the orientation of technological and institutional change in such a manner as to ensure the attainment and continued satisfaction of human needs for present and future generations. Such sustainable development (in the agriculture, forestry and fisheries sectors) conserves land, water, plant and animal genetic resources, is environmentally non-degrading, technically appropriate, economically viable and socially acceptable”*. Thus, the key goals of sustainable agriculture are to seek:

- ♦ Ways of incorporating natural processes (like nutrient cycles, pest and predator relationships) within the production system.
- ♦ Minimization in the use of non-renewable and off-farm inputs.
- ♦ Equitable and fair access to means of production and opportunities.
- ♦ Means to move towards socially just agricultural development.
- ♦ Enhancement in the degree of self-reliance amongst the farmers and rural households.
- ♦ Long-term sustainable production volumes.
- ♦ A production that uses processes like integrated farm management and conservation of resources (water, soil, nutrients/ energy/ etc.) and at the same time is profitable and efficient. (Pretty et al., 2011).

Table 1.1. Dimensions and levels for assessing agricultural sustainability in the thesis. Source - ([Hayati et al., 2010](#); [Zhen and Routray, 2003](#))

Dimension	Level	This Thesis
Normative	•Ecological aspects •Economic aspects •Social aspects	Considers environmental, economic, and social aspects concurrently.
Spatial	•Local •Regional •National	Considers small farms of developing countries.
Temporal	•Long-term •Short-term	Balances the short-term oriented economic and agronomic indicators with the long-term oriented economic, social, environmental, and agronomic indicators.

Several researchers and agencies working in sustainable agricultural practices have proposed various sustainability assessment supports (methodology/ methods/ guidelines/ tools) that cater to different target groups, needs, and goals. However, there are no supports that aid in the design process. The assessment supports can be categorized into monetary, biophysical, or indicator-based support families. The sustainability assessment supports based on indicators and composite indices have become central to the Sustainable Development debate since it: *“...can provide crucial guidance for decision-making in a variety of ways. They can translate physical and social science knowledge into manageable units of information that can facilitate the decision-making process. They can help to measure and calibrate progress towards Sustainable Development goals. They can provide an early warning, sounding the alarm in time to prevent economic, social and environmental damage. They are also important tools to communicate ideas, thoughts and values because as one authority said, We measure what we value, and value what we measure.”* ([United Nations, 2001](#)).

Farm power and mechanization are essential agricultural inputs to enhance labor and land productivity and help meet the SDGs of ending poverty and hunger, as set by the UN ([Sims and Kienzle, 2016](#)). Mechanization saves time and farm labor, reduces drudgery, optimizes crop production costs in the long run, and reduces post-harvest losses ([Clarke, 2000](#); [Clarke and Bishop, 2002](#); [Reid, 2011](#); [Sims and Kienzle, 2016](#)). Mechanization brings in 15-20% savings in seeds and fertilizers, time and labor requirement declines by 20-30%, and productivity increases by 10-15% ([Pandey, 2008](#)). Thus, agricultural output data collected over the years shows that farm power availability and food grain productivity are directly related. An increase in productivity can also result in a farm income boost. Studies on farm mechanization assessment using an LCD perspective (environmental dimension) are present. However, there are no sustainability-oriented design or assessment supports available to design and develop SAM considering the three sustainability dimensions concurrently.

[Sims and Kienzle \(2017\)](#) describe SAM *“as mechanization that is economically feasible, environmentally sensitive and socially acceptable.”* Food and Agricultural Organization of the UN (FAO) ([2016b](#)) describes SAM as: *“Sustainable agricultural mechanization covers all levels of farming and processing technologies, from simple and basic hand tools to more sophisticated and motorized equipment. It eases and reduces hard labor, relieves labor shortages, improves productivity and timeliness of agricultural operations, improves the efficient use of resources, enhances market access and contributes to mitigating climate-related hazards. Sustainable mechanization considers technological, economic, social, environmental and cultural aspects when contributing to the sustainable development of the food and agricultural sector.”* Thus, it suggests that the farm mechanization design process should follow a system-oriented design approach that connects the *“technical, economical and engineering aspects”* of machinery design with the allied service ecosystem. The allied service ecosystem should contain *“linkages and inter-dependencies with other sectors”* which will together offer a holistic view of conducting agriculture. Thus, the sustainability-oriented design process entails the need for supports that can aid in assessment and design, considering all the three dimensions of sustainability concurrently, the entire life cycle of the AM and the entire agricultural value chain around it.

Researchers ([Baudron et al., 2015](#); [Bezruk et al., 2014](#); [Brinks and Kool, 2006](#); [Corti et al., 2015](#); [Gathorne-Hardy, 2016](#); [Hendrickson et al., 2008](#); [Jongebreur and Speelman, 1997](#); [Romanelli and Milan, 2012](#); [Sims and Kienzle, 2015, 2016, 2017](#); [Sims et al., 2016](#); [Sims and Kienzle, 2006](#); [Sims and Kienzle, 2009](#); [Sims et al., 2012](#); [Veisi, 2012](#); [Vieri and Sarri, 2010](#); [Ziout and Azab, 2015](#)), as well as [FAO \(2016b\)](#), provide a broad outline for the design for SAM. However, there are no detailed sustainability-oriented design or assessment supports available to aid a designer in the complex challenge of

- ♦ connecting the “*technical, economical and engineering aspects*” of machinery design with the allied service ecosystem
- ♦ establishing the “*linkages and inter-dependencies with other sectors*”
- ♦ to offer a holistic view of conducting agriculture.

Thus, the thesis aims to formulate sustainability-oriented design support for SAM's assessment and design, considering all three sustainability dimensions concurrently. It balances short-term oriented economic and agronomic indicators with the long-term oriented economic, social, environmental, and agronomic indicators. It specifically considers the context of small farms (less than 2 hectares) of developing countries to develop the design support. The rationale for the context selection is:

- ♦ [FAO, International Fund for Agricultural Development and World Food Program \(2015\)](#) stress the need for focusing on the management of small farms, i.e., farms less than 2 hectares in size, to fight the global battle against hunger and malnutrition.
- ♦ The UN's SDG (2.3) targets to double the agricultural productivity and incomes of the smallholders of developing countries to eradicate poverty and hunger by 2030.
- ♦ The data also shows that 74% of the landholdings in developing countries is less than 1 hectare and 12% in the 1-2-hectare range ([Lowder et al., 2016](#)).
- ♦ Two-thirds of the developing countries' rural population (~2 billion people) live in 475 million small farm households ([Nagayets, 2005](#)).

The thesis uses a DSR methodology to formulate the design support. DSR aids in theory-building by solution or technology invention using naturalistic and artificial evaluation methods ([Venable, 2006](#)). Following the DSR methodology's spirit, the research work presented in the thesis targets to design, develop, and test a solution (*BP*) to a real-world problem (*bed planting in small farms of South Bangladesh*) following an iterative design process. During this process, a theoretical framework (*D-SAM and G-SAM*) for designing interventions for the same class of problems (*SAM for small farms of developing countries*) is devised. Evaluation and validation of this theoretical framework shows that it can be used for a broader set of scenarios in the same class of problems (*tested further on other SAM for small farms of developing countries*).

The key contributions of the thesis are:

- ♦ The development of a sustainability-oriented design for SAM methodology called as D-SAM. It helps in
 - ♦ strategic analysis, including a sustainability assessment of the existing scenario and sustainability priority setting for the design,
 - ♦ ideation process,
 - ♦ design and engineering of the product, service, and system, and
 - ♦ the sustainability improvement or worsening assessment of the redesigned SAM offer.
- ♦ The development of a sustainability-oriented design for SAM guideline called as G-SAM. It helps in the sustainability assessment of the existing scenario, sustainability priority setting for the

design, and the ideation process. It puts forward three perspectives for assessment and design in front of the designer: 1. S.PSS design; 2. Design for a sustainable agricultural outcome; and 3. Environmentally sustainable product design. G-SAM provides open-ended ideation cues to guide, educate, and inform a designer during the design process. The assessment is conducted using rapid sustainability assessment indicators.

1.1. Thesis structure

[Chapter 2. Agricultural Mechanization and Sustainability](#) presents the agricultural scenario in developing countries of the world. It argues how farm power and mechanization are essential for agricultural intensification in the small farms of the developing countries but face unaddressed design and sustainability challenges. Thus, the context for designing SAM is set. The chapter concludes with the thesis research objectives, questions, and scope.

[Chapter 3. Research Methodology](#) details the research methodology, the rationale for selecting it, and the thesis's research stages. The thesis uses the approach of DSR as developed by ([Peffers et al., 2006](#)) and improvised by ([Gleasure et al., 2012](#); [Reubens, 2016](#)).

[Chapter 4. Sustainability-Orienting Design Approaches](#) sets the stage for identifying and analyzing various DfS approaches, identifying the existing design supports applicable for the sustainability-oriented design of SAM, and the rationale for selecting the most applicable ones. The design supports investigated are either design methodology, methods, guidelines, or tools. The study of various DfS approaches reveals that a S.PSS design approach that connects the “*technical, economical and engineering aspects*” of machinery design with the allied service ecosystem will be the most suitable. However, the machinery's LCD is also argued to be of high importance to ensure environment-friendly performance. Thus, the chapter concludes with selecting an LCD toolkit and an S.PSS design methodology for further efficacy evaluation for SAM's sustainability-oriented design.

[Chapter 5. Case Study: Sustainability-oriented design of a Bed Planter](#) presents the application of the selected LCD toolkit and S.PSS design methodology on a SAM design context to check for their efficacy and sufficiency. The SAM design context selected is a redesign exercise for a BP for Bangladesh's small farms. The chapter concludes with the identification of three gap areas in the existing sustainability-orienting design methodologies. One was the lack of product design focus since the S.PSS design methodology focused on service and system design. Stages and processes were added to the base methodology to fill the product design gap. Second, it lacked any metrics for evaluating sustainability in agriculture as one is a generic S.PSS methodology and the other a generic product design toolkit. They are not designed considering the SAM design context. Thus, a Sustainable Agriculture Criteria (SAC) checklist, designed in consultation with stakeholders from various agricultural knowledge domains and literature research, is also drafted here. Thirdly, the scenario demanded special attention to participatory design, considering highly educated stakeholders like engineers and scientists and illiterate or semi-literate stakeholders like farmers and local service providers (LSPs) designing together. The chapter suggests the inclusion of participatory design methodology, for both assessment and design, in the base methodology processes.

[Chapter 6. D-SAM, a sustainability-oriented design methodology for agricultural machinery and its associated service ecosystem design](#) theorizes a sustainability-oriented design methodology, called D-SAM, for designing SAM for small farms of developing countries. A set of guidelines, called G-SAM, is theorized in this chapter for rapid sustainability assessment and providing design cues. G-SAM aids in sustainability assessment and design by combining three different perspectives: 1. Sustainable

product-service system design, 2. Design for a sustainable agricultural outcome, and 3. Environment-friendly product design.

[Chapter 7. Evaluation and validation](#) presents an evaluation methodology, criteria, and the evaluation results of using G – SAM for the design of SAM for different contexts. G-SAM is validated through eight SAM case studies from two developing countries by professionals and students.

[Chapter 8. Conclusion](#) concludes the thesis's key research findings, highlights the major contributions and limitations of the research. It concludes with a discussion on the scope for future research in the given domain.



2. Agricultural mechanization and sustainability

UN has set food security and sustainable agriculture as the top priorities for development on the global front ([United Nations, 2012](#)). The Global Food Security Index uses three core issues to measure food security in 113 countries ([The Economist Intelligence Unit, 2018](#)). The three indexes are *affordability, availability, and quality and safety*. While looking for avenues for boosting agricultural growth to achieve food security sustainably, it is essential to be wary of the environmental and socio-economic impact of the growth-boosting activities. The developing countries across the globe, where this balancing act is a significant challenge, are the focus of this thesis. Thus, this chapter first describes the agricultural scenario in developing countries and situates its challenges. Next, it steers the readers towards challenges specifically related to the domain of farm power and mechanization. Next, it presents the context behind the problem tackled in this thesis: the sustainability-oriented design of AM for small farms of developing countries. The final section presents the research objectives and the research questions answered in the thesis.

Problem identification and motivation
Definition of: Research Problem context Justification for the need of a solution Research objective Research questions

2.1. The agricultural scenario in developing countries of the world

The Oxford dictionary defines agriculture as “the science or practice of farming, including cultivation of the soil for the growing of crops and the rearing of animals to provide food, wool, and other products.” According to FAOSTAT ([2018](#)), 45% of the global population lives in rural areas. A large number of them engage in various agricultural and allied activities. The share of employment in agriculture is going down globally, 41.3% in 1995 to 26.7% in 2016. However, the share of the same in developing countries is still very high. For example, the average share of employment in agriculture in the African continent is 53.2%. In India, half of the population is engaged in the agricultural sector. Agriculture accounts for 13.7% of the GDP of India and 11% of its exports. In many developing countries, the share of agriculture in the national GDP is between 20 - 60% ([The World Bank Group, 2020a](#)). A unique characteristic of farms in many developing countries is their small size. The challenges of making smallholder farms economically viable for sustainable development is one of the key issues ([Bisht et al., 2020](#)). FAO, International Fund for Agricultural Development and World Food Program ([2015](#)) stress the need for focusing on the management of small farms, i.e., farms less than 2 hectares in size, to fight the global battle against hunger and malnutrition. The SDG 2.3 also targets smallholders and states - “By 2030, double the agricultural productivity and incomes of small-scale food producers, in particular women, indigenous peoples, family farmers, pastoralists and fishers, including through secure and equal access to land, other productive resources and inputs, knowledge, financial services, markets and opportunities for value addition and non-farm employment”. ([FAO, 2016c](#)). Indicators 2.3.1 ([FAO, 2016c](#)) and 2.3.2 ([FAO, 2016d](#)) together measure the SDG 2.3 target.

The SDG 2.3.1 states - “Indicator 2.3.1 - Volume of production per labor unit by classes of farming / pastoral / forestry enterprise size: This indicator refers to the value of production per labor unit operated by small scale producers in the farming, pastoral and forestry sectors. Data will be produced by classes of enterprise size. The indicator will measure progress towards SDG Target 2.3”. ([FAO, 2016c](#))

The SDG 2.3.2 states - “Indicator 2.3.2 Average income of small-scale food producers, by sex and indigenous status: The indicator refers to the average income of small-scale food producers employed in the farming, pastoral and forestry sectors. Data will be disaggregated sex and indigenous status. This indicator will measure progress towards SDG Target 2.3”. ([FAO, 2016d](#))

It is imperative to have a universally acceptable definition of smallholder farms to operationalize and measure progress towards the SDG target 2.3. However, there is no universal definition of smallholder farms. The term is used to denote various concepts like “small-scale agriculture”, “family farms”, “subsistence farm”, “resource-poor farm”, “low-income farm”, “low-input farm” or “low-technology farm” (Heidhues and Brüntrup, 2003). However, a large part of the literature defines small farms as those with less than 2 hectares in the operated area (Khalil et al., 2017). According to GRAIN (2014), out of 122 countries across the globe whose national statistical authorities have a definition of smallholders, 71 use farm size as the definition criteria. The threshold size of the smallholding, however, varies from less than 1 hectare to even values greater than 10 hectares in certain geographies. Also, agro-ecology and demographic conditions, economics, and technology penetration play a role in farm size distribution and characterization. For example, two hectares of land in a semi-arid region are not equivalent in terms of productivity to the same size of land in a well-irrigated fertile land. Thus, the threshold value of 2 hectares is not considered as a piece of meaningful information for cross-analysis across geographies (Rapsomanikis, 2015). The other definitions use the threshold and typology of labor, the management structure of the holding, market participation, and economic size to classify smallholders (Khalil et al., 2017).

2.1.1. Smallholdings

A study amongst 14 developing countries in Asia shows that 85% of the operational holdings are less than 2 hectares in size (Asia and Pacific Commission on Agricultural Statistics, 2010). The average landholdings in Asia and the Pacific region are amongst the smallest in the world (World Programme for the Census of Agriculture (WCA), 2010). In India, the number of small and marginal farmers is estimated to be close to 126 million, and they together own about 74.4 million hectares of land, an average of 0.6 hectares per farmer (Bisht et al., 2020). India also owns 24% of the world’s agricultural holdings (Lowder et al., 2016). In Nepal, farmers holding land below 1 hectare account for 40% of the total cultivated land (Khalil et al., 2017). The average size of a smallholder farm in Viet Nam is 0.32 hectares, and in Bangladesh, it is 0.24 hectares (Rapsomanikis, 2015). In China, 98% of farms are smaller than 2 hectares, and China accounts for 35% of the world’s agricultural holdings (Lowder et al., 2016). Appendix 1 shows the percentage of small agricultural holdings from across the globe (for countries whose data is available) along with information on the income group, region, and economic development classification of the countries. Table 2.1 below summarizes the countrywide data in three groups based on income, region, and economic classification. The data clearly shows that countries with lower-middle-income and low-income have a high percentage of holdings less than 1 hectare in size. For the upper-middle-income group, the percentage of holdings smaller than 1 hectare is vast, but these holdings together constitute only a minuscule fraction of the total operated area. The data also shows that developing countries have 74% of their holdings less than 1 hectare and 12% in 1-2-hectare range.

Table 2.1. Distribution of smallholdings across the globe (Lowder et al., 2016).

Country Groups	Total no. of countries	No. of countries for which data is available	Total holdings (~ million)	Total area (~ million ha)	Agricultural holdings <1 ha		Agricultural holdings 1-2 ha	
					%	% of Operated Area	%	% of Operated Area
Income-based grouping								
High-income	83	47	26	744	35	0.5	17	1
Upper-middle-income	56	28	241	724	84	1	7	1.3
Lower-middle-income	50	17	160	244	62	15	18	16
Low-income	29	11	26	28	62	19	21	19

Region-based grouping								
East Asia and Pacific	38	16	244	215	86	4	8	5
Europe and Central Asia	58	34	24	256	34	1	18	2
Latin America and The Caribbean	43	22	12	562	18	0.2	10	0.3
The Middle East and North Africa	21	11	13	43	59	5	11	5
North America	3	2	2	447	0	0	0.3	0
Sub-Saharan Africa	48	15	27	33	58	16	21	17
South Asia	8	3	130	182	62	18	19	19
Economic classification-based grouping								
Developed Economies	36	35	24	699	34	0.5	16	1
Developing Economies	157	65	427	1037	74	4.7	12	5
Emerging Economies	17	3	2	5	51	9.2	23	12

Smallholding is a relative concept and depends on aspects like the agro-ecological context and the socio-economic context ([Lowder et al., 2016](#)). Thus, a small farm from Latin America and the Caribbean is a large farm by definition in Asia or Sub-Saharan Africa. Although there is no clear-cut definition of small farms, a close look at the SDG indicators 2.3.1 and 2.3.2 points out that they aim to look at all those farmers who are at a disadvantageous position due to the size of their holding and availability of other resources and opportunities which comes along with it. Small-sized holdings possess several challenges due to lower access to inputs (machinery, seeds, fertilizers, technology, labor, credit), markets, and opportunities. This thesis focusses on smallholdings where mechanization cannot be introduced on an ownership-based model (elaborated in [2.2.6](#) and [2.3](#)). The mechanization of such holdings finds better economic viability and density of use when used on a custom-hiring format. Hence, the small farms in this thesis deal with concepts like “small-scale agriculture”, “family farms”, “subsistence farm”, “resource-poor farm”, “low-income farm”, “low-input farm” or “low-technology farm” ([Heidhues and Brüntrup, 2003](#)).

2.1.2. Characteristics and challenges of smallholdings in developing countries

This section summarizes the characteristics and challenges of smallholdings in developing countries and helps to contextualize mechanization.

2.1.2.1. Shrinking size

Out of the 66 low, lower-middle, and upper-middle-income countries whose data is available, 55 countries report that the average size of their agricultural holdings has reduced from 1960 to 2000 ([Lowder et al., 2016](#)). That can be attributed to various reasons. For example, as per the Agricultural Census of Government of India 2010-11, the average size of the landholdings for all operational classes have declined from 2.82 hectares in 1970-71 to 1.16 hectare in 2010-2011 ([Government of India, 2014a](#)). Factors like an increase in demand for industrialization, urbanization, housing, and infrastructure is leading to the conversion of agricultural land into non-agricultural use in India. In the case of Russia, the average farm size has decreased since liberalization and land reforms ([Sedik and Lerman, 2008](#)). Also, changes in farm size are dependent on the rural population and the rate of urbanization and urban migration. It is estimated that Asia will soon reach a turning point in its farm size decrease trend due to this population dynamics while African countries will see further decrease in farm size for many years to come ([Masters et al., 2013](#)). Thus, to achieve an acceleration in agricultural growth, the focus has to lie on increasing productivity and reducing wastage. Data shows that farm mechanization increases the availability of farm power, which in turn helps in increasing cropping intensity. It also

saves time and farm labor, reduces crop production costs in the long run and post-harvest losses. Mechanization brings in 15-20% savings in seeds and fertilizers, time and labor requirement declines by 20-30%, and productivity increases by 10-15% (Pandey, 2008). Agricultural output data collected over the years, thus, shows that farm power availability and food grain productivity are directly related. An increase in productivity can also result in a farm income boost. Thus, given the fact that farm sizes in the developing countries cannot be expanded and might shrink further in many cases, appropriate mechanization along with other technological improvements in inputs along with economic and policy-level interventions can boost the productivity and income following the SDGs.

2.1.2.2. Lower levels of mechanization

FAO's data portrait of smallholder farms (FAO, 2015), currently mapping 19 countries, presents a systematic and standardized data set on the profile of smallholder farms. Figure 2.1 shows the average small farm's size as compared to other farms in these countries. As shown in Figure 2.2, these smallholder farms mostly have low levels of mechanization. Most of the farm activities are achieved through manual labor, family labor, or hired. Apart from the FAO's data portrait of the 19 countries, other sources report that the level of mechanization in India is about 40-50%, in China, it is at 57% and in Brazil at 75% (Renpu, 2014). The percentage of farms less than 1 hectare in India, China, and Brazil is 63%, 93%, and 11% respectively while those in the range of 1-2-hectares are 19%, 5%, and 10% respectively.

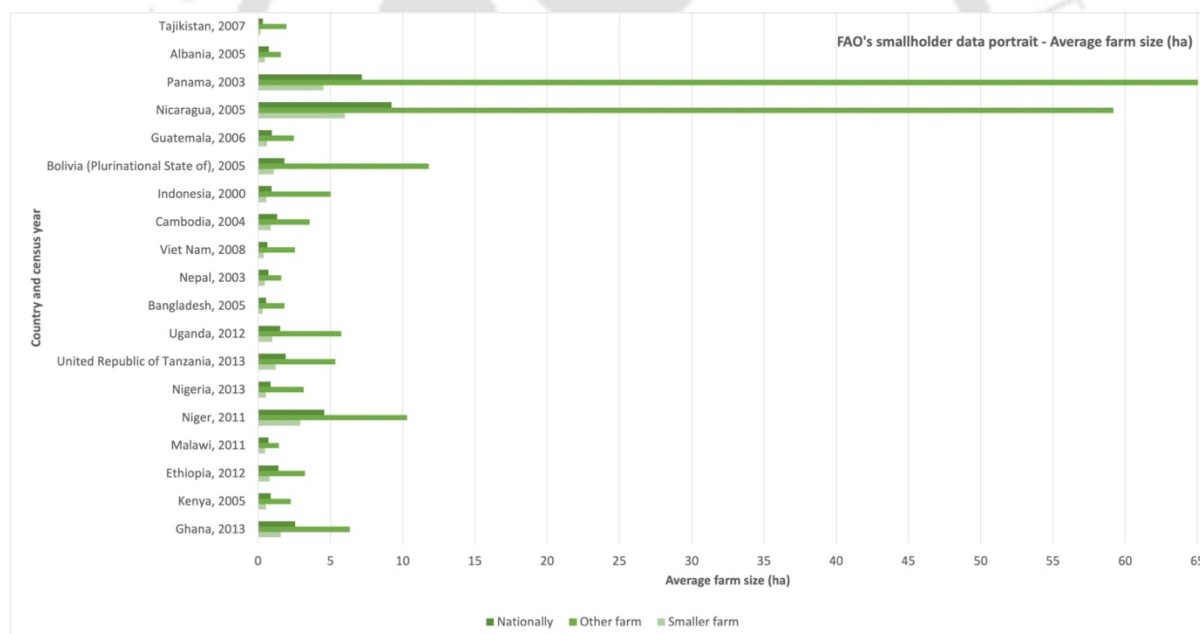

Figure 2.1. FAO's smallholder data portrait - Average farm size (ha). Source: (FAO, 2015)

2.1.2.3. Dynamics of the local economy, infrastructure, and connectivity to markets

Not all smallholder farms across different countries and also within the same country are similar. The status and nature of small farms are dependent on the economic status of the country and the region as well as the availability of infrastructure and proximity to markets (Masters et al., 2013; Rapsomanikis, 2015). (Reardon, 2013) According to studies in Asia, small farms located closer to the urban areas or ones well connected to them show a decrease in transaction costs and improvement in capital availability. As per estimates, about 50-70% of Asia's food production is commercialized, implying is sold to the urban markets through intermediaries. This has increased the access of these farms to all sorts of agri-inputs like credit facilities, agri-tech in terms of improved seeds, fertilizers, pesticides, AM, and cold storage facilities. In these contexts, there has been a sharp increase in the use

of AM through a custom-hiring model. Also, the input suppliers in these contexts have been able to combine innovations from public sources with theirs to produce locally adapted technologies (Pray, 2013). On the other hand, smallholders in the hinterlands of the same countries have not yet benefited from these (Reardon, 2013). However, the production in these smallholder farms contributes to a great extent to meet the food demands of the rural families cultivating them.

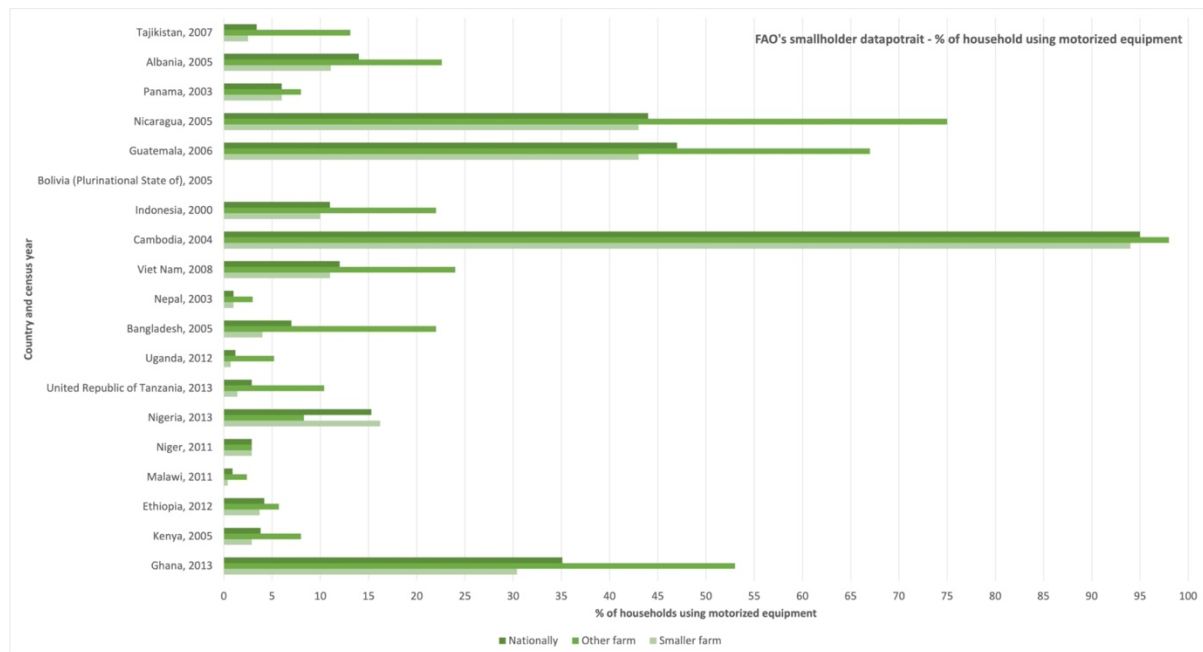

Figure 2.2. FAO's smallholder data portrait - % of households using motorized equipment. Source: (FAO, 2015)

2.1.2.4. Contribution to food production

As per estimates of several organizations and researchers, smallholder farms contribute to 70-80% of the world's total food production (ETC Group, 2009; FAO, 2014; Wolfenson, 2013). Some more conservative calculations put the value at 30-34% (Herrero et al., 2017; Ricciardi et al., 2018; Samberg et al., 2016). India's smallholders together cultivate 33% of its land and produce 41% of the country's food grains (Singh et al., 2002). For the smallholders of Kenya, Tanzania, and Nepal, the percentage for their respective countries is 63, 69, and 70 (FAO, 2015). Smallholders are also the key players in the conservation of crop diversity (Altieri, 2008; Badstue et al., 2005; Conway, 2011). They also produce more food per hectare than larger farms (FAO, 2015; Horrigan et al., 2002; Naylor et al., 2005). Figure 2.3 below shows data comparing small vs other farms from the FAO's smallholder data portrait on the value of food production per hectare (const. 2009 Int. \$) (FAO, 2015). It presents evidence that small farms have higher productivity than their larger counterparts. Smallholders also tend to diversify their production to mitigate risks and meet their food requirements (Pope and Prescott, 1980). However, in the wake of increasing commercialization, specialized production picks up in response to market prices and demand (Pingali and Rosegrant, 1995).

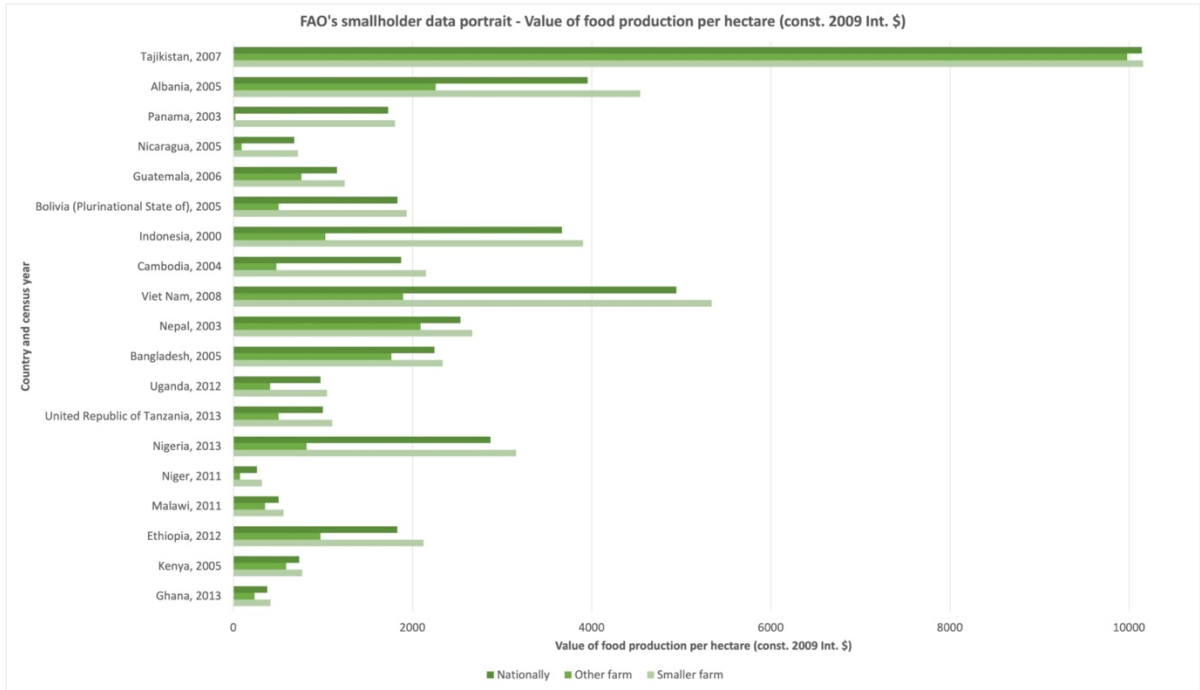

Figure 2.3. FAO's smallholder data portrait - Value of food production per hectare (const. 2009 Int. \$). Source: (FAO, 2015)

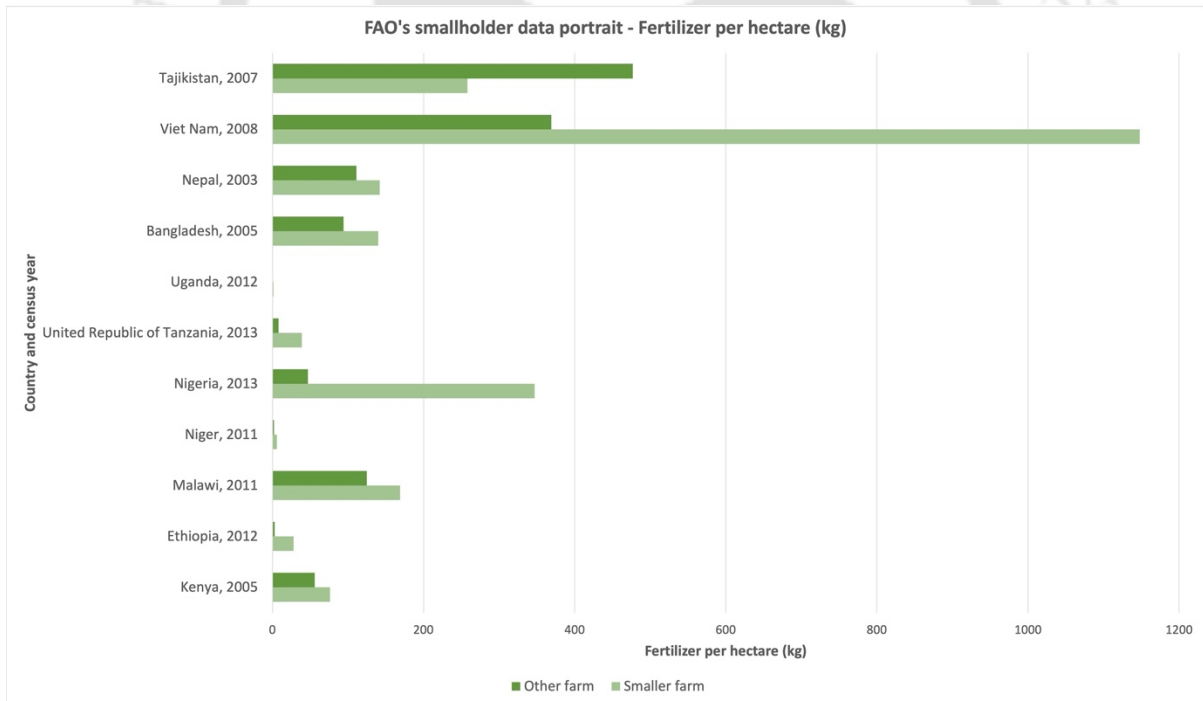

Figure 2.4. FAO's smallholder data portrait - Fertilizer per hectare (kg). Source: (FAO, 2015)

2.1.2.5. Input usage pattern

Inputs like fertilizers and seeds which are crucial to production intensification are used in much larger volumes by smallholders than larger farmers in a given country. Figure 2.4 and Figure 2.5 show FAO's smallholder data on the same. This is not an indication of a higher access to these inputs for the smallholders in the given country. For example, Kenyan farmers on average (national) use 72 kg of fertilizers per hectare, while European farmers use 130 kg per hectare. The data implies that within the

country, there is a huge gap between small and other farm holders. Small farms in Kenya use an average of 76 kg per hectare of fertilizers while other farms use 56 kg per hectare only. Indian agricultural data (Figure 2.6 and Figure 2.7) also shows that its marginal and small farms use way much more chemical fertilizers and farmyard manure than its larger farms. This strategy of increased input use might be seen as a substitute for the volume of land they own (Rapsomanikis, 2015). Fertilizers can substantially increase yields by enriching the soil when combined with improved seeds. However, this increased use in fertilizers can put the water resources at risk, increase soil salinity, and impact the health of the people.

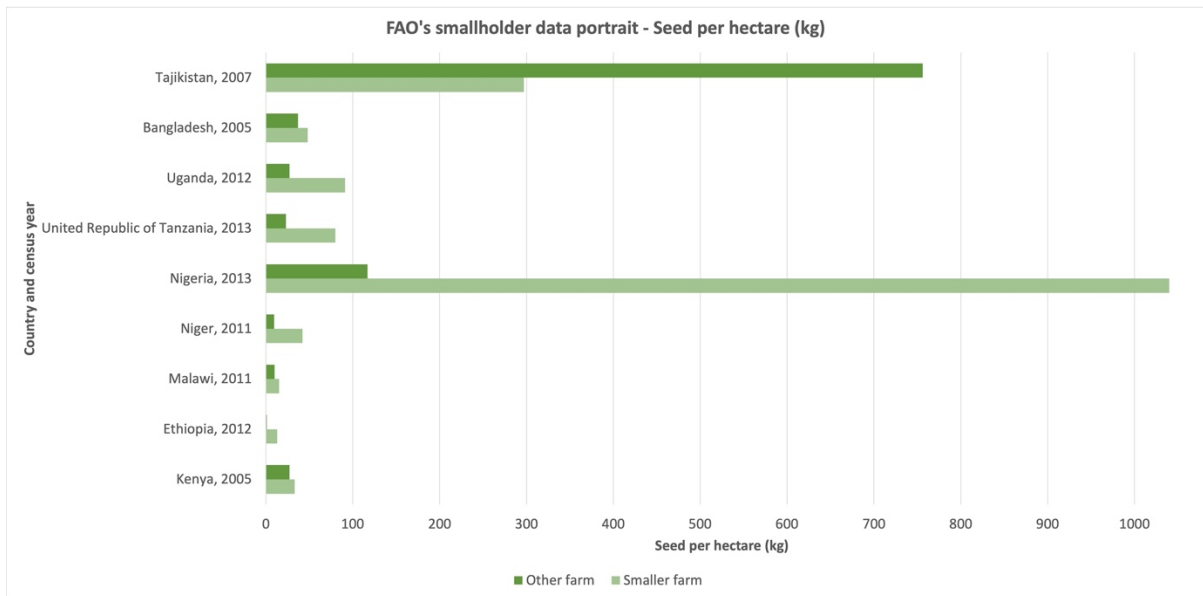

Figure 2.5. FAO's smallholder data portrait - Seeds per hectare (kg). Source: (FAO, 2015)

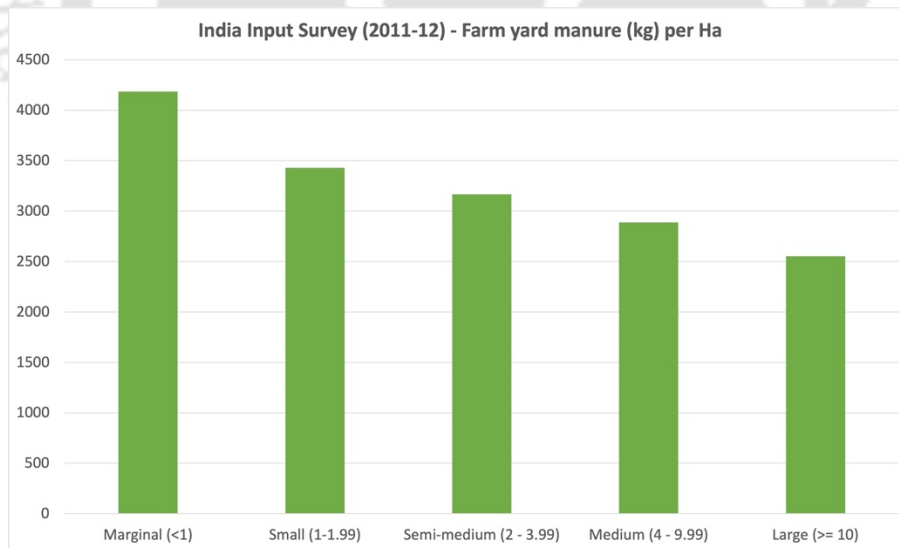

Figure 2.6. India Input Survey (2011-12) - Farmyard manure (kg) per Ha. Source - (Agriculture Census Division, 2011-12)

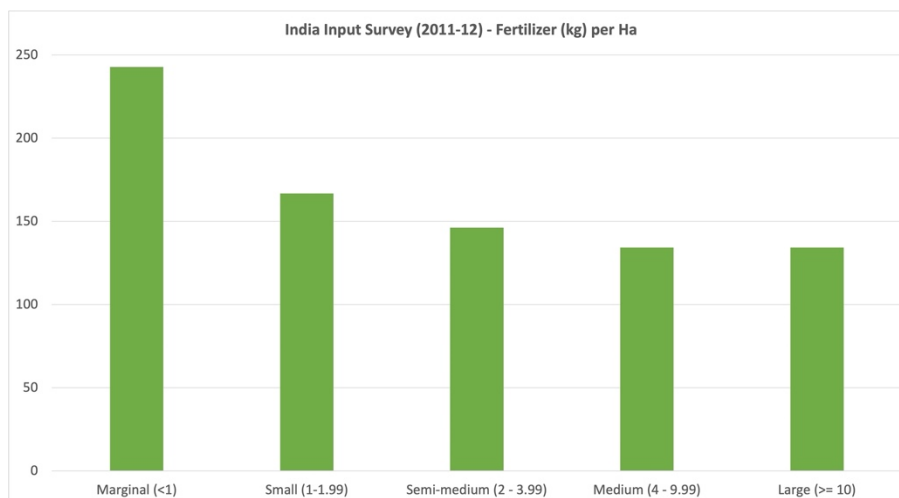

Figure 2.7. India Input Survey (2011-12) - Fertilizer (kg) per Ha. Source - ([Agriculture Census Division, 2011-12](#))

2.1.2.6. An inverse relationship between farm size and productivity

Another interesting aspect observed across the globe is, small farms have higher productivity than their larger counterparts (within the same country). This inverse relationship between farm size and productivity is represented in [Figure 2.3](#) with examples from 19 developing countries. The inverse relationship, amongst several factors, can be attributed to labor and the fact that they use higher inputs per hectare ([Lamb, 2003](#)). The labor-management in small farms is easier than in larger farms as a large part of the labor is comprised of family members ([Figure 2.8](#)), their motivation for work is higher ([Example - Cheng et al., 2019](#); [Larson et al., 2012](#); [Rapsomanikis, 2015](#)). However, according to global estimates, the productivity growth of smallholders has slowed down. The gap between the smallholders' yield and technical potential yields reflects suboptimal use of inputs and insufficient adoption of productivity-enhancing technologies. In 2005, the yield gap was estimated to be around 11% in East Asia and as high as 76% in Sub-Saharan Africa ([FAO, 2015](#)). [Figure 2.9](#) summarizes the yield gap estimates from various developing regions of the world. Thus, policies directed to aid smallholders to enhance their productivity is crucial to achieving food security. The differences in yields per hectare vary significantly across geographies due to agro-climatic conditions, cropping intensity, crop-mix, input use, capital availability, market access, knowledge access, and degree of adoption of modern technologies ([Rapsomanikis, 2015](#)). ([Mimeo et al., 2011](#)) Also, the study reveals that the farm size advantage to the productivity of small farms erodes over time as their productivity increase is slower than that of larger farms. Data from Mexico from 2002 and 2007 shows that the loss in strength of the inverse relationship was around 25%. The primary cause of the erosion is due to transformation in food supply chains requiring smallholders to learn new managerial skills, meet food safety, certification and quality demands, adopt new technologies (which are scarcely developed for smallholders) and secure capital and storage facilities. Data from India also shows that the productivity per hectare decreases as the size of farm increases from marginal (<1 ha), small (1 - 1.99 ha) to semi-medium (2-3.99 ha) but thereafter starts increasing with the increase in farm size ([Ranganathan, 2015](#)). The economies of scale work against the smallholders in securing the resources as mentioned above.

2.1.2.7. Family farms

Small farms are also family farms. Family farms have varying definitions across countries and contexts. The majority of these definitions imply that the role of family labor is significant, and the family manages the farm operations ([Garner and de la O Campos, 2014](#)). Small farms do employ hired labor but mostly rely on family labor, as is evident from data presented in [Figure 2.10](#). Small farms use more labor than capital to produce food. The hired labor is mostly seasonal like employed during the sowing or harvesting season. Due to the extensive involvement of family labor, the productivity of the

small farms is higher (Figure 2.11). (Rapsomanikis, 2015) Also, family farms are said to overuse family labor, more than the level that will bring profit-maximization. This can be attributed to the lack of alternative well-paid job opportunities in rural areas. Due to low income from farm activities, many smallholder farmers and their family members work off the farm as well (FAO, 2015). For example, out of the 2.7 million Nepalese smallholder households, 2.25 million reports working in off-farm jobs like carpenters, bricklaying, blacksmithing, or self-employment activities like retailing, wholesaling, rice mill owners. Also, around 47% work in the agricultural sector as hired labor on a seasonal basis. (Kayastha et al., 1999). This helps in building income resilience for the smallholders (Rapsomanikis, 2015) and also provides them access to credit at times (Shepherd and Kayunze, 2011).

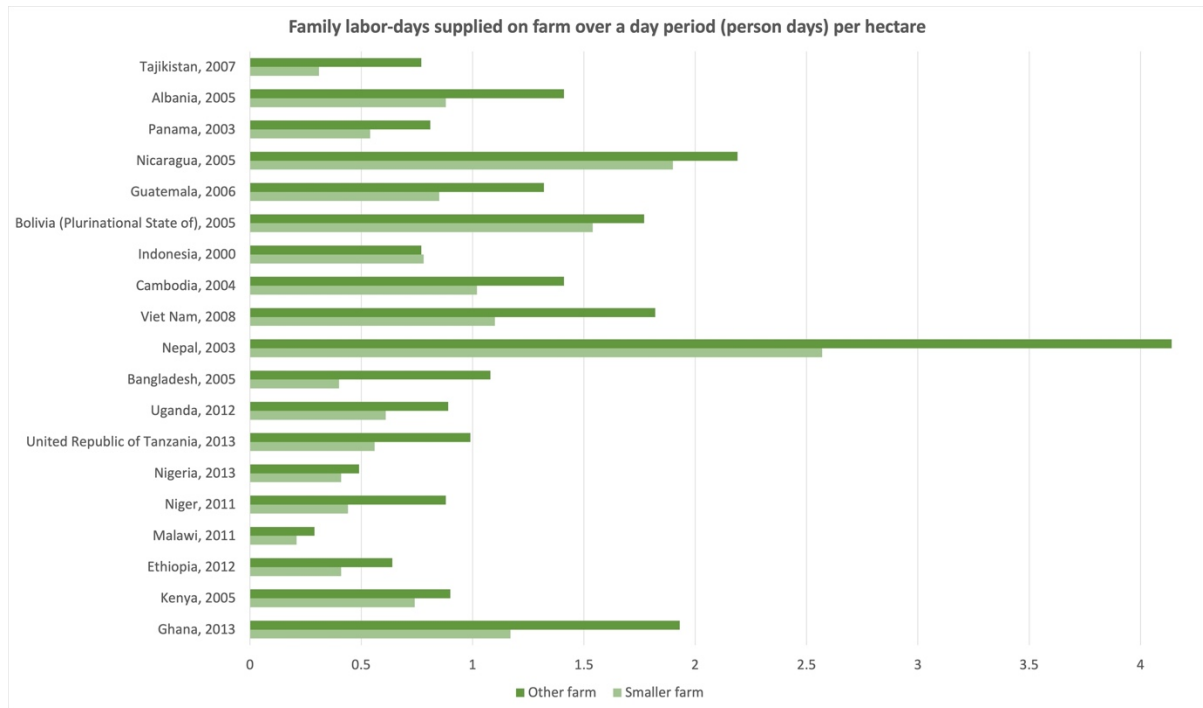

Figure 2.8. Family labor-days supplied on-farm over a day (person-days) per hectare. Source: (FAO, 2015)

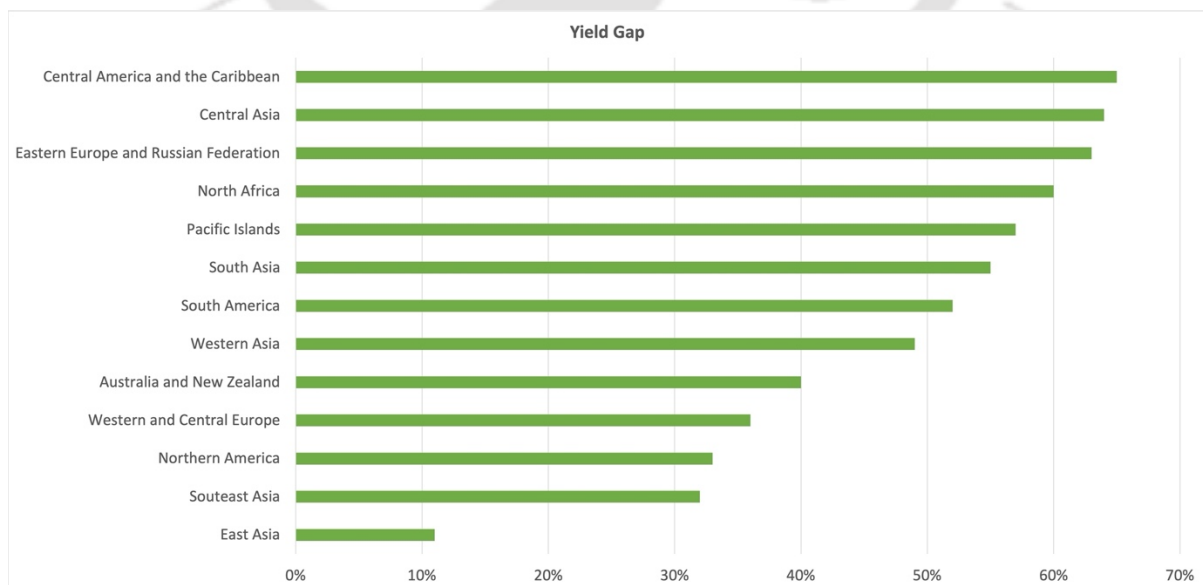

Figure 2.9. Estimated yield gaps for major crops (cereals, roots and tubers, pulses, sugar crops, oil crops, and vegetables), by region, 2005. Source - (FAO, 2015)

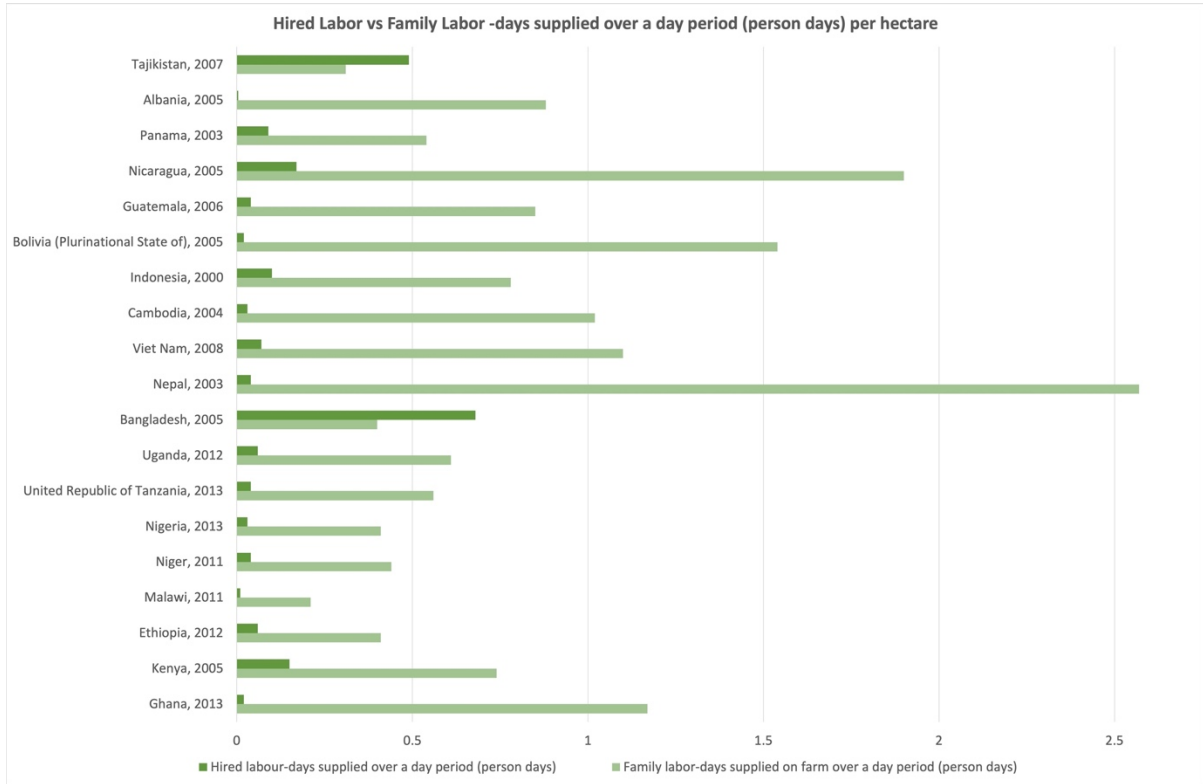

Figure 2.10. Hired Labor vs Family Labor -days supplied over a day (person-days) per hectare. Source: (FAO, 2015)



Figure 2.11. Relationship between productivity and family workers (Author's calculation using data from Source: (FAO, 2015)).

2.1.2.8. Feminization of agriculture

In developing countries, an average of 43% of the agricultural labor force comprise of women (Figure 2.12). They perform various jobs on the farm alongside their unpaid household work leading to hefty workloads. Statistical comparison between female-headed and male-headed smallholder farms shows that women are way lower in terms of use of inputs like seeds, fertilizers, AM (Figure 2.13) and have lower access to capital and market. It is estimated that if women farmers have the same access to productive resources as their male counterparts, they could bring in an increase in their farms' yield by 20-30%. This can help in hunger alleviation of 100-150 million people and raise the agricultural output in developing countries by 2.5-4%. It is reported that women in Sub-Saharan Africa tend to engage in

the production of maize, fruits, and vegetable and rear small animal, while those in Asia are heavily engaged in rice production, and those in Latin America tend to manage small plots on farms to cultivate food crops and raise poultry and small livestock. Women also tend to drive more sustainable production systems and bring forth a varied and healthier diet to their family's table. Also, investing in women brings forth economic returns for smallholder farmers. ([Altieri and Koohafkan, 2008](#); [Chakrabarti, 2014](#); [FAO, 2011](#); [Fontana and Paciello, 2009](#); [Rapsomanikis, 2015](#)).

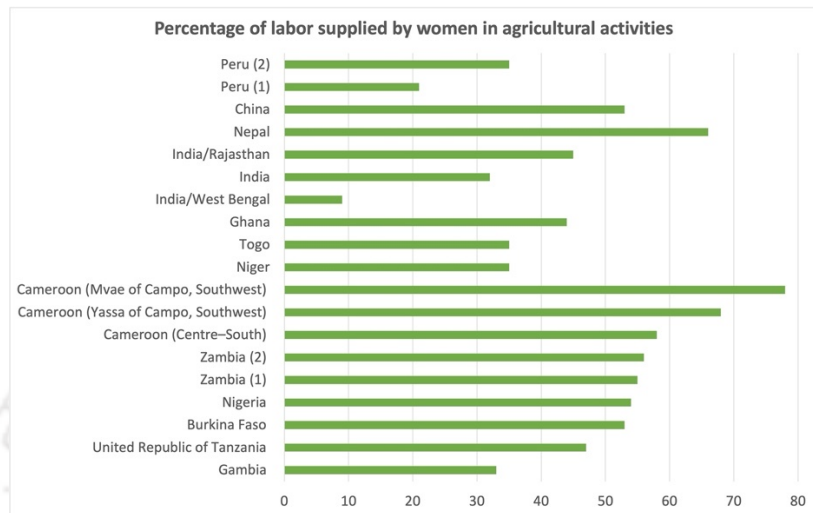

Figure 2.12. Proportion of labor in all agricultural activities that are supplied by women. Source - ([FAO, 2011](#))

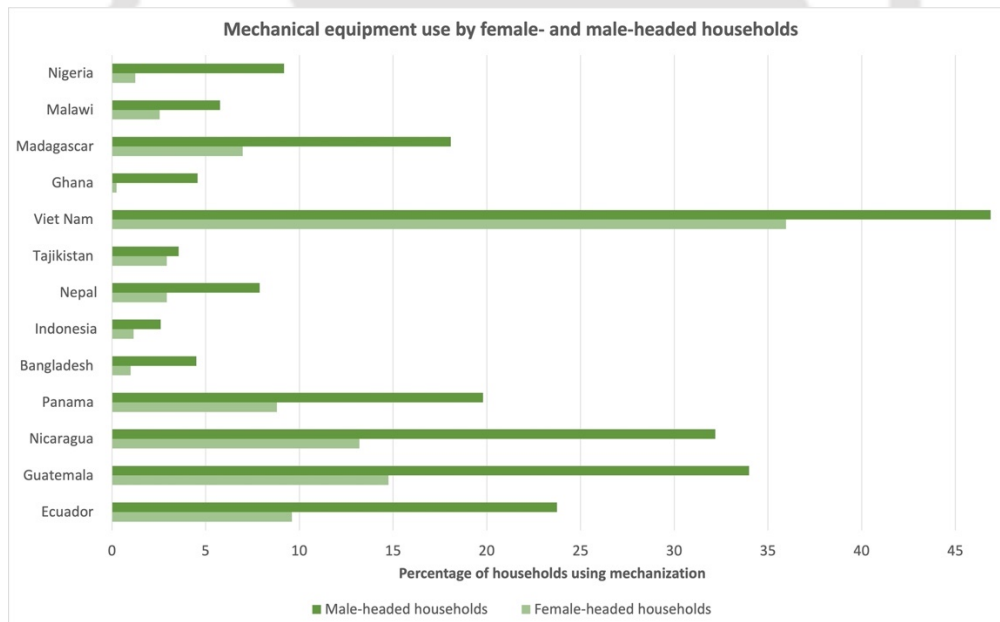

Figure 2.13. Mechanical equipment use by female- and male-headed households. Source - ([FAO, 2011](#))

2.1.2.9. Irrigation

Irrigation is key to productivity as it generates higher yields, reduces the risk of crop failure, provides year-round farm and non-farm employment, increases diversity in the cropping pattern, and helps farmers to switch from subsistence farming to market-oriented farming. The irrigation scenario of smallholders varies significantly from country to country. In Nepal, for example, 67% of smallholder land is irrigated while 94% of other farms are irrigated. ([Directorate of Economics and Statistics, 2018](#)) The total area under irrigation in China is about 14%, and that in India it is 39%. In India, the area under

47% of marginal farms and 40% of small farms are irrigated. African developing countries have overall more limited access to irrigation facilities than the Asian countries (FAO, 2015). The overall level of irrigation in a country is a crucial determinant of irrigation levels of smallholders (Example - Gandhi and Namboodiri, 2009; Roy and Shah, 2002; Shah et al., 2006; Wang et al., 2012; Zhang and Anadon, 2014). In many parts of the developing countries, irrigation facilities rely heavily on groundwater and pump to extract them. This has led to the depletion of groundwater levels and increased the cost of water mining. Irrigation relying on rivers has resulted in a decrease in river discharges in arid and semi-arid regions, increased pollution levels, resulted in soil salinity, and poses health risks to farmers (Example - Ensink et al., 2006; Liu et al., 2013).

2.1.2.10. Human capital

Human capital here deals with farmers' knowledge, skills, health, or values and has a significant influence on agricultural productivity. Since agricultural productivity is dependent on productivity-enhancing technology and their appropriate use, farmers need to possess the knowledge and skills to acquire and assimilate appropriate information and technology. They also need to be able to adapt their practices to suit the ever-changing agricultural and agri-business demands. Thus, economists suggest the need to measure human capital in terms of the number of years spent in school or the expenditure on education and health. Statistical data from India on the educational status of its farmers shows that there is not much difference in the educational levels of farmers, whether they are marginal, small, semi-medium, medium, or large farm holders (Table 2.2) (Agriculture Census Division, 2011-12). About a third of the Indian farmers are illiterate, and 75% of the farmers have not studied beyond middle school. Data from FAO's smallholders' data portrait also shows that the educational status of farmers of developing countries, in general, irrespective of farm size, is low (Figure 2.14). Given the current agricultural and agri-business trends, a focus on enhancing the farmers' educational and skill level must be of utmost importance (Singh et al., 2002).

Table 2.2. Estimated number of operational holdings by educational status, an all India summary (Agriculture Census Division, 2011-12)

Size Group (Ha)	Educational Qualifications of Operational Holders (%)						
	Illiterate	Up to Class V	Middle	Secondary	Senior Secondary	Technical Diploma	Graduate & Above
Marginal (< 1.0)	31	22	23	15	5	1	2
Small (1.0 - 1.99)	30	23	22	15	6	1	3
Semi-Medium (2.0 - 3.99)	29	23	22	16	6	1	3
Medium (4.0 - 9.99)	29	24	21	16	6	1	4
Large (>=10)	31	22	19	15	6	2	5
All Groups	31	22	23	15	5	1	2

2.1.2.11. Age of the farmer

Many of the developing countries are experiencing the aging of their population. Aging is a crucial factor in determining a farmer's level of involvement in various agricultural activities like sowing seeds, harvesting, applying fertilizer. Statistical data from India shows that the average age of its operational holders is about 50 years across all holding sizes with more than 50% of them being above 50 years (Table 2.3). The aging of India's population combined with the rapid migration of the younger population towards more industrialized urban centers is making the agricultural situation challenging (Sharma, 2007). Aging will have implications on the workforce, production patterns, land tenure, social organization in rural communities, and economic development. Similarly, China reports that 32.5% of its labor force in the agricultural sector is old. Studies by researchers conform to the trend of aging and

its negative impact on productivity ([Li and Zhao, 2009](#); [Tang and MacLeod, 2006](#)). However, very few studies are reported on aging and its impact on agriculture and its productivity in the developing countries' smallholder farms. Nevertheless, soon this will be an area of concern and can be mitigated through various interventions at policy levels and farms levels (for example, the introduction of appropriate mechanization to ease agricultural activities).

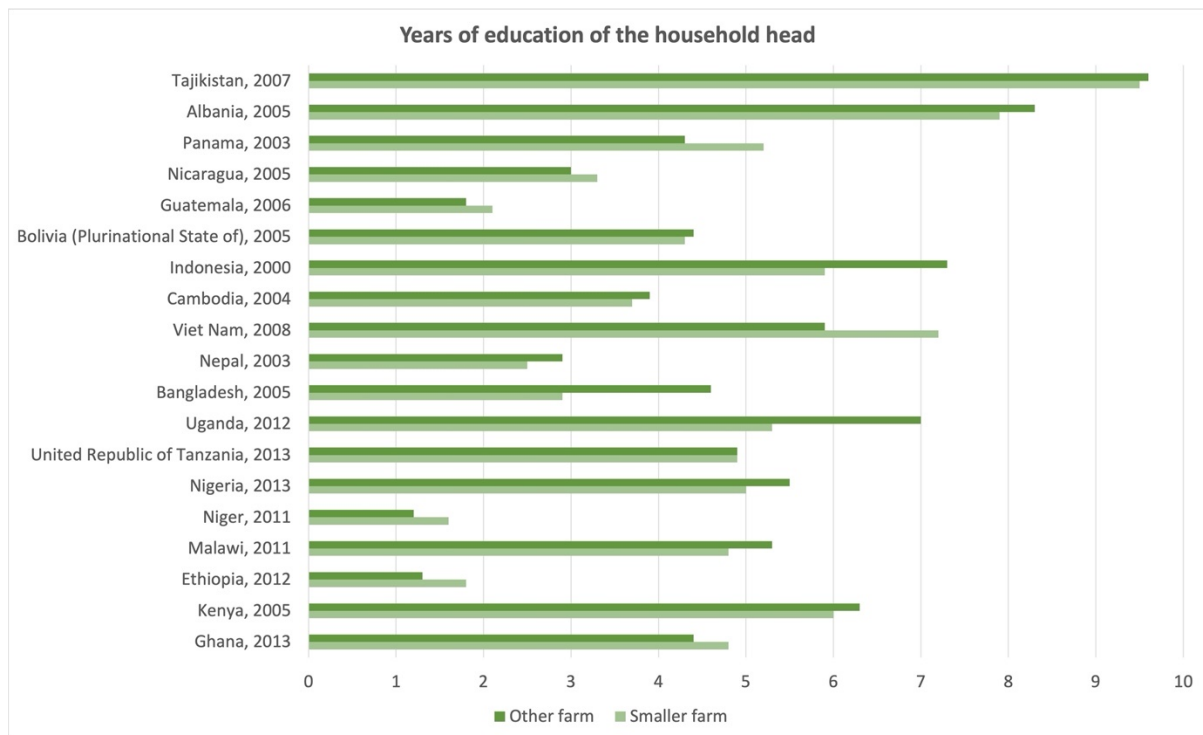

Figure 2.14. Years of education of the household head. ([FAO, 2015](#))

Table 2.3. Distribution of Operational Holder (%) in different Age Groups with Average Age (years) ([Agriculture Census Division, 2011-12](#))

Size Group (Ha)	Distribution of Operational Holder (%) In Different Age Groups with Average Age (Years)						Average Age
	18-30 Yrs	31-40 Yrs	41-50 Yrs	51-60 Yrs	61-65 Yrs	> 65 Yrs	
Marginal (< 1.0)	3	12	35	34	10	6	50.08
Small (1.0 - 1.99)	4	15	33	31	11	6	49.61
Semi-Medium (2.0 - 3.99)	4	13	31	32	12	8	50.47
Medium (4.0 - 9.99)	4	12	29	32	13	10	51.23
Large (>=10)	3	9	28	34	14	13	52.72
All Groups	3	13	34	33	11	6	50.1

2.1.2.12. Income, poverty, credit, and consumption

A farm household usually earns its income from various sources like income from cultivation, rearing livestock, wages, and salary of some of the household members engaged in employment outside their household and from non-farm businesses. Income from sources other than cultivation is an important source of income for smaller farmers. ([Ranganathan, 2015](#)). With limited income, the farmers have to meet a range of expenses like purchasing food, inputs for farming, and paying for other necessities like clothing, education, medical services. [Figure 2.15](#) shows FAO's data on smallholders' percentage of expenditure for inputs on the value of production. In some countries like Cambodia,

Malawi, and Kenya, this accounts for more than 40%. Hence, a lot of smallholders live in poverty and own a lesser number of production-enhancing and income-generating assets like certified seeds, machinery, and livestock. Due to the lower usage of AM, the dependence of smaller farms on agricultural labor is high. Due to lower creditworthiness, the percentage of them who gain institutional credit facilities for supporting agriculture is also generally low (Figure 2.16). Also, amongst smallholders, non-farming jobs and business are important income generators. The diversification of income also helps them to manage adverse shocks like floods, market fluctuations. However, the availability of such opportunities varies from country to country and region to region.

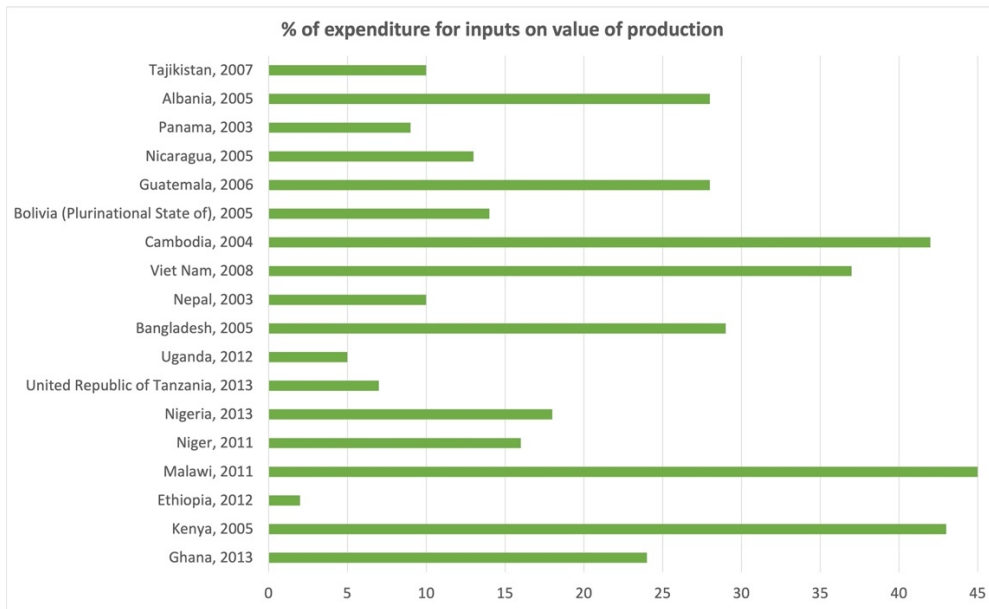

Figure 2.15. % of expenditure for inputs on the value of production. (FAO, 2015)

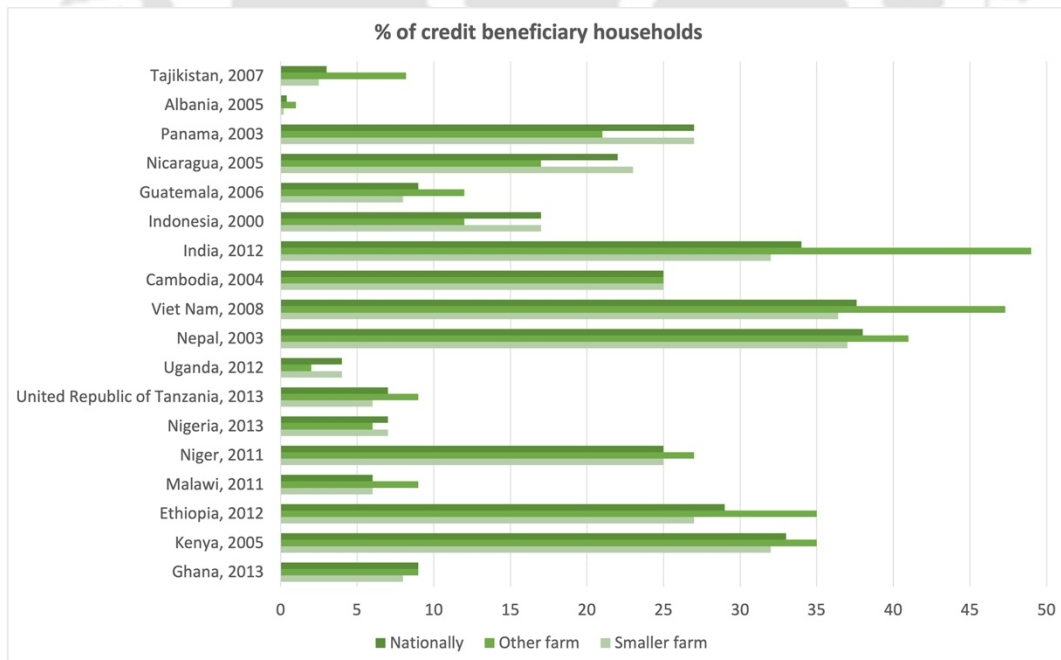

Figure 2.16. % of credit beneficiary households. Indian data - (Agriculture Census Division, 2011-12), Other data - (FAO, 2015)

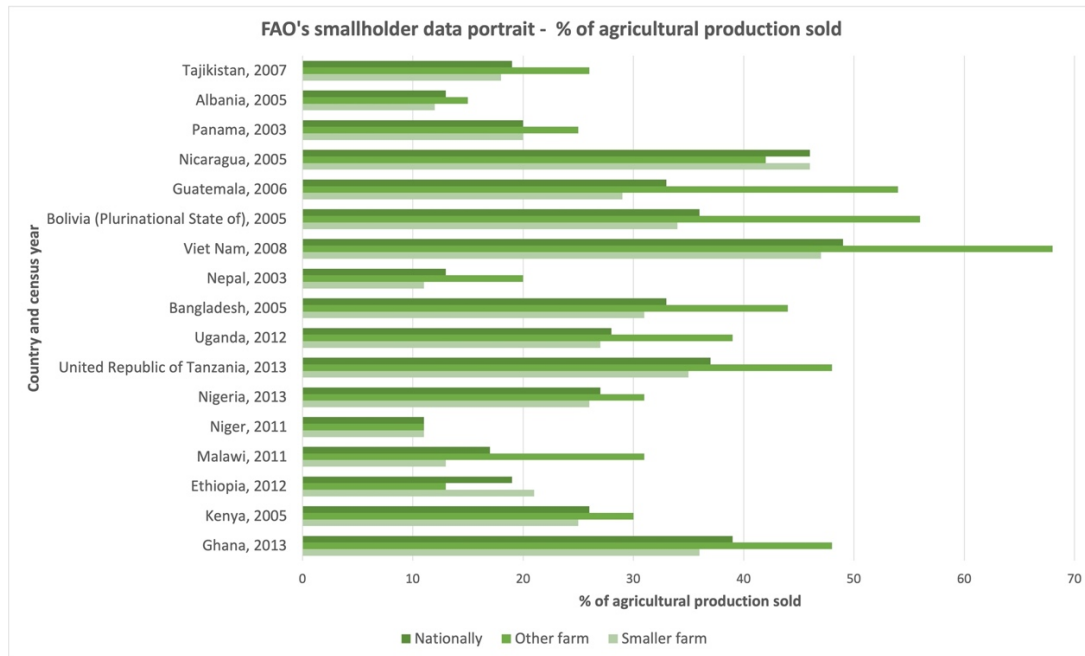

Figure 2.17. % of agricultural production sold - (FAO, 2015)

(Rapsomanikis, 2015) For smallholder farmers, a large part of their earnings is spent on food. For example, in the United Republic of Tanzania, where an average smallholder farmer with a household of 5 members earns 1.9\$ per day, spends 81% of its earnings on food. Thus, under such circumstances, a large part of the food produced by them is used for self-consumption rather than sale (Figure 2.17). The scenario varies from country to country. In Nicaragua, 60% of the budget is for food while in Nepal it is 26% for buying food and 33% of the market value of their produce. The lower-income also leads to lower spend on human capital, i.e., education and health which in turn comes in their way of learning and adopting new production-enhancing technologies.

2.1.2.13. Cost of farming

Profitability from farming depends on the cost of farming and the value of agricultural production. An increase in input costs can adversely affect profitability. Globally a trend towards a rise in custom hiring of AM by smallholders is visible as it reduces labor costs and improves profitability (Example from – Eastern and Southern Africa (Baudron et al., 2019); Ghana - (Kansanga et al., 2018); India (Ranganathan, 2015); Nepal - (Paudel et al., 2019). (Ranganathan, 2015) An analysis of change in India on cost and value of agriculture (across all classes of holdings) between 2002-03 and 2012-13 Kharif crops show that for farm households, the total value of their production increased by 262% while the total cost of farming increased by 216%. There is a decrease in the share of expenditure on seeds, fertilizers, and manual labor. On the other hand, the share of expenditure on lease rent and costs like machine hiring, irrigation, diesel, electricity, animal labor, marketing, etc. has increased. Plant protection cost and interest cost-share have almost remained constant. This indicates that the trend towards the use of AM is on the rise. The profitability measured as total value versus total cost ratio has improved for all classes in the timeframe except for the lowest class (.01 - .4 ha) of landholders. The improvement is higher for larger farms than the smallholdings. This shows that the economics of cultivation is eroding for smallholders. For the Rabi crops in the country, the total value has increased by 194% while the total cost by 182%. The profitability rise is lower and shows similar trends as Kharif crops. For the smallholders, machine hiring cost has gone up showing the trend towards consumption of AM following custom-hiring based models.

The cost of farming also depends on market typology and access. Sales of agricultural produce through channels like supermarkets need the farmer to learn managerial and logistical skills and at the same time ensure continuity of supply and meet safety and quality standards. However, achieving the same by individual smallholders is difficult as the current norms for the same are in favor of large-scale producers ([Reardon et al., 2009](#)). In case the farms are located further away from roads, the transaction cost of bringing the produce to the market or traders rise. However, many smallholders do reach their produce to the market successfully through collaborations in the form of cooperatives and other informal groups. Many farmers are also forced to sell their produce immediately post-harvest at lower prices due to lack of storage or value addition possibilities or merely due to the need for cash. ([Rapsomanikis, 2015](#)).

The impact of environmental degradation on the cost of farming has been reported by several researchers. For example, a study on rice and wheat production in the state of Punjab in India shows that on account of decline in the water table, depleting macro and micronutrients and increased use of pesticides, the cost of producing wheat and rice went up by Rs 63/t and Rs 189/t respectively from 1981 to 2001 (measured at constant prices of 2002-03) ([Singh and Sidhu, 2006](#)). ([Sangha, 2013](#)) Intensive cropping leads to nutrient deficiency in the soil and makes agriculture more dependent on fertilizer usage. This leads to increased input costs and a decline in profit margins. ([Sangha, 2013](#); [Sidhu et al., 2010](#)) Due to the propagation of high yielding varieties of crops and growing of specific high return crops only, the local varieties of crops, as well as wild plants, are disappearing fast. This, on the one hand, is causing loss of biodiversity and on the other hand, is making crops more vulnerable to pest attacks. As a result, the need and consumption of pesticides have gone up.

2.2. Farm power and farm mechanization

Farm mechanization describes the tools, implements, and machinery used to enhance farm and farm-labor productivity ([Sims et al., 2016](#)). Farm mechanization increases the availability of farm power, which in turn helps in increasing cropping intensity. Thus, power and mechanization are essential agricultural inputs to enhance labor and land productivity and helps to meet the SDGs 1 (ending poverty) and 2 (ending hunger) ([Sims and Kienzle, 2016](#)).

Table 2.4. Estimated number of AM used by operational holding as on 15th October 2001 by size groups in India (Agricultural Census, Input Survey, 2001-02)

Size Group (Ha)	Number of (~ in millions)		
	Hand Operated Implements	Animal Operated Implements	Power Operated Implement/Equipment
Marginal (< 1.0)	323	134	35
Small (1.0 - 1.99)	125	68	21
Semi-Medium (2.0 - 3.99)	84	48	19
Medium (4.0 - 9.99)	44	25	13
Large (≥ 10)	10	5	3
All Groups	586	280	91

Farm power can be available in the form of:

- ♦ Human power using hand-operated tools like hand seed drill, pedal-operated thresher, winnowing fan, maize sheller, chaff cutter, hand operated sprayer or duster, hand hoe, wheel hoe, blade hoe, paddy weeder, tree pruner chaffer, budding and grafting knives, garden fork.
- ♦ Draught animal-powered implements like a wooden plow, steel plow, disc harrow, cultivators, seed-cum fertilizer drills, seed planter, bullock cart.

- ◆ Power-operated implements like tractor-drawn or power-tiller drawn seed drill, disc harrow, levelers, planter, etc., or electric or diesel driven pump sets, power-operated sprayer.

The mix of the three options used in a given context varies based on factors like availability, affordability, suitability, socio-cultural trends, costs, labor typology available, nature of the operation, marketing, credit availability, government policies. For example, agricultural input survey data from India shows that small and marginal farmers use all three types of farm power ([Table 2.4](#)). However, the share of agricultural costs like machine hire, diesel, and electricity is rising rapidly for the marginal and small farmers showcasing the fact that power-driven mechanization through custom hiring of AM is gaining momentum amongst them ([Ranganathan, 2015](#)). According to a study by ([Singh, 2010](#)), the sales of tractors in India are dependent on the availability of credit facility, brand popularity in a region, after-sales service facility, fuel efficiency, maintenance cost, and resale value and also at times on the tractor looks and driver convenience. India is the global leader in the production of tractors and exports to developed country markets as well ([Radjou, 2009](#)). However, mechanization in India has not been uniform. It shows a large variation between states as well as operations. The north-western states are heavily mechanized while the hilly north-eastern states have low levels of mechanization ([Government of India, 2014a](#)). ([Mehta, C.R. et al., 2014](#)) Operation-wise, 42% of soil working and seedbed preparation, 29% of seeding and planting, 34% of plant protection, and 37% of irrigation are mechanized. Also, the level of mechanization is at around 60-70% for wheat and rice whereas for other crops it is less than 5%. ([Biggs et al., 2011](#)) Despite the dominance of small farms, the proliferation of 2WT in India is small. Bangladesh, a developing country, on the other hand, is primarily dominated by small farms and is heavily mechanized (80%¹). The power is mostly delivered by small engines like 2WT. The push for the same came during the mid-1990s due to severe losses to draught animals due to natural calamities hitting Bangladesh and the agricultural policy advisors of the time advising the national premiere to look at 2WT as a suitable alternative. Also, World Bank's market liberalization and lowering of tariffs for Bangladesh played a role in the same. Small Chinese make diesel engines for pump-sets, threshers, trailers, and 2WT have propelled the mechanization processes in Bangladesh, Srilanka, and Nepal. ([Paudel et al., 2019](#)) A study in the mid-hills of Nepal shows that smallholders' willingness to pay for the purchase of 2WT was positively influenced by farm size, local wage rates, out-migration, access to credit services, and associations with agricultural cooperatives while negatively influenced if they owned a larger number of draft animals. On average, farmers were willing to pay 31% less than the actual price of 2WT. Thus, the case for the need for custom hiring based services crops up in this context. ([Sims and Kienzle, 2006](#)) In Sub-Saharan Africa, it is estimated that 65% of the power for land preparation and weeding is still provided by human muscles. Thus, a typical family can cultivate around 1.5 hectares per year only if they use human power exclusively. Adding draught animal power can enhance that to 4 hectares while tractor power to 8 hectares. Studies in the United Republic of Tanzania brought in an interesting way to look at mechanization by designing agronomic processes (conservation agricultural techniques) in which the need for mechanization reduces. In Ghana, there is a rise in the availability of mechanized plowing services due to government subsidies and the availability of hiring services offered by the private sector ([Kansanga et al., 2018](#)). In a study conducted in Ethiopia, it was observed that being a model farmer, female-headed farm household, having a larger land holding, employing a higher number of female labors, owning a higher number of oxen, being younger and having good experience in the use of herbicides had a positive impact on farmers' willingness to use tractor hiring services in an otherwise traditionally oxen-powered farming ecosystem ([Takele et al., 2018](#)).

¹ FAO's definition of tractors specifies four-wheeled tractors and excludes two-wheeled power tillers. That is the reason behind the difference in FAO's data portrait figures reported in [Figure 2.2](#) and those reported by Biggs, S., Justice, S., Lewis, D., 2011. Patterns of rural mechanisation, energy and employment in South Asia: Reopening the debate. Economic and Political Weekly, 78-82.

Mechanization saves time and farm labor, reduces drudgery, optimizes crop production costs in the long run, and reduces post-harvest losses ([Clarke, 2000](#); [Clarke and Bishop, 2002](#); [Reid, 2011](#); [Sims and Kienzle, 2016](#)). Mechanization brings in 15-20% savings in seeds and fertilizers, time and labor requirement declines by 20-30%, and productivity increases by 10-15% ([Pandey, 2008](#)). Agricultural output data collected over the years, thus, shows that farm power availability and food grain productivity are directly related. An increase in productivity can also result in a farm income boost. Since small farms support over 500 million families in the world and account for 70-80% of farmland and food produce ([FAO, 2014](#)), it is essential to design strategies for mechanizing the same following DfS principles. With increased rural to urban migration causing labor shortages and increasing the number of female-headed farm households, the need for appropriate mechanization is considerable ([Baudron et al., 2015](#); [Rosegrant et al., 2014](#); [Sims and Kienzle, 2017](#)). ([FAO, 2016b](#)) According to FAO's Sustainable Agricultural Mechanization (SAM) program, if farmers have access to improved agricultural tools and powered technologies, they can shift from subsistence agriculture to market-oriented farming. This can also provide the incentive for younger generations to continue with farming. FAO suggests that SAM should follow the principles of conservation agriculture and the paradigm of "Save and Grow".

([Breuer et al., 2015](#); [Sims and Kienzle, 2015](#)) AM can potentially contribute to the sustainable food value chain development by aiding in:

- ♦ Production processes – soil preparation, soil nutrient management, crop establishment, fertilizing, irrigation, plant care, crop protection, and harvesting.
- ♦ Post-harvest processes – value addition processes like drying, grading, winnowing, cleaning, boiling, and storage.
- ♦ Processing processes – chopping, milling, grinding, and pressing.
- ♦ Distribution processes – packaging and transportation.

2.2.1. Examples of sustainability concerns of agricultural mechanization

Mechanization, not considering environmental sustainability issues can negatively impact the agroecosystem by causing soil compaction, soil erosion, forest and rangeland destruction, and damages caused due to over-use of chemical-based fertilizers and pesticides ([Sims and Kienzle, 2016](#)). This will result in agriculture becoming more expensive and eventually economically unviable for smallholders. Although AM is regarded as one of the key success criteria in the Green Revolution that took place in many parts of Asia in the 1960s and 1970s, it has also brought in several detrimental effects to it. The number of studies in identifying the damaging effects of AM and its associated service ecosystem on the socio-economic and environmental sustainability is very less. Some of the reported unsustainability caused due to the presence or absence of certain typologies of AM and its associated service ecosystem on the three dimensions of sustainability are:

- ♦ As per the study by the [Government of Punjab \(2005\)](#), [Venugopal \(2004\)](#), and [Singh \(2009\)](#), farmers tend to purchase and use higher power tractors and pumps than what they need. This results in underutilization of machinery and hence economic losses for them. The reported underutilization is comparatively higher on small farms than other farms. The farmers' lack of technical knowhow due to lower education levels adversely affects their purchase decisions.
- ♦ Soil degradation due to AM is a well-documented phenomenon that hardly deters farmers from using them. For example, rotavator aided full tillage damages soil structure ([Ogle et al., 2005](#)). However, it is highly preferred machinery. As the soil quality degrades, agriculture becomes more dependent on fertilizers leading to increased input cost, reduction in profit margins, and further soil and water degradation and pollution ([Sangha, 2013](#)). A study on rice and wheat production in the state of Punjab in India shows that on account of decline in the water table, depleting macro and micronutrients and increased use of pesticides, the cost of producing wheat and rice went up

by Rs 63/t and Rs 189/t respectively from 1981 to 2001 (measured at constant prices of 2002-03) ([Singh and Sidhu, 2006](#)).

- ◆ Conservation agriculture has proven to be beneficial to both soil and productivity. However, the shortage of mechanization along with support services for smallholders to practice conservation agriculture is hindering its adoption. For example, in South Asia 2WT based implements and Africa animal-powered implements for conservation tillage have been introduced. However, conservation tillage needs support services like training in the usage of herbicides. In absence of the same, extensive manual weed removal processes involving high labor costs makes the practice of conservation agriculture impractical for smallholders. Also, the added problem with herbicides is their high cost and the environmental and health hazards that they might possess. ([Johansen et al., 2012](#)).
- ◆ AM is largely powered by diesel which in turn is provided by the government at subsidized prices. This has indirectly deterred designers from exploring alternate renewable sources of energy for powering mechanization.
- ◆ Due to the outward migration of rural youth, these areas are becoming predominantly populated by women, children, and the elderly. This reduces the availability of farm labor. In the absence of appropriate AM and labor shortages, timely farm operations are becoming difficult leading to the abandonment of farming and further out-migration. That has increased the burden on urban infrastructure. It also increases the drudgery of women, children, and the elderly in rural areas.
- ◆ Apart from rice and wheat, most other crops lack complete mechanization packages that cater to the entire value chain of the crop type ([Mehta, C.R. et al., 2014](#)). Since a value chain approach is not taken, the full benefits of mechanization in terms of productivity and profit enhancement are not being realized. It makes cultivation and processing of these crops labor-intensive, expensive, and uncertain due to lack of timely availability of labor.
- ◆ Subsidized pumps and diesel have brought in the possibility of irrigation to huge stretches of land. However, since no efforts have been made to connect groundwater mining and recharging, excessive groundwater mining had led to a sharp decrease in the water table, increased risk of soil salinity, arsenic poisoning, shortage of water availability for human consumption, and increased the cost of mining water for agriculture. ([Sangha, 2013](#); [Shah, 2007](#)).
- ◆ Studies conducted in the Indian state of Punjab, connect shift to commercialized agriculture with adverse effects like loss of rural non-farm jobs and businesses (like carpenters, lock-and-smith) which were dependent on making agricultural tools; disruption in social relations and values (cultural, health, and economic); huge farmer debts leading to an increase in suicides; other social problems like female feticide, unemployment and meager career options leading to substance addiction in the youth ([Government of Punjab, 2002](#); [Sidhu and Johl, 2002](#); [Sidhu et al., 2010](#)).

Thus, well-intentioned technological solutions for the farm sector, not considering the impact of the same on the environment, economy, and social dimension, have in the long-run and sometimes even in the short-run fallen into the trap of being unsustainable. Also, the examples show that technological solutions for mechanization need to be designed in association with an appropriate service ecosystem to achieve sustainability, i.e., environmental efficiency, economic viability, and social equity.

2.2.2. Sustainable agricultural mechanization

SAM is described “as mechanization that is economically feasible, environmentally sensitive and socially acceptable” ([Sims and Kienzle, 2017](#)). FAO’s website on SAM ([FAO, 2016b](#)) describes SAM as: “Sustainable agricultural mechanization covers all levels of farming and processing technologies, from simple and basic hand tools to more sophisticated and motorized equipment. It eases and reduces hard labour, relieves labour shortages, improves productivity and timeliness of agricultural operations, improves the efficient use of resources, enhances market access and contributes to mitigating climate related hazards. Sustainable

mechanization considers technological, economic, social, environmental and cultural aspects when contributing to the sustainable development of the food and agricultural sector.” Thus, it suggests that the farm mechanization design process should follow a system-oriented design approach that connects the “technical, economical and engineering aspects” of machinery design with the allied service ecosystem. The allied service ecosystem should contain “linkages and inter-dependencies with other sectors” which will together offer a holistic view of conducting agriculture. Thus, the design process entails the need for integration of a multitude of stakeholders, both large- and small-scale, like manufacturers, service providers, farmers, and governments. The stakeholders might have varied kinds of interests like research, profit-orientation, non-profit, government, etc.

2.2.3. SAM for conservation agriculture

Conservation agriculture “is a farming system that promotes minimum soil disturbance (i.e. no tillage), maintenance of a permanent soil cover, and diversification of plant species. It enhances biodiversity and natural biological processes above and below the ground surface, which contribute to increased water and nutrient use efficiency and to improved and sustained crop production” (FAO, 2017). In many parts of the world, the soil has degraded due to intensive farming. The cost of farming has increased since more fertilizers are required to replete soil nutrients, increased cost of water mining, and increased costs for controlling insect and weed populations. Conservation agriculture practices have proved to be economically beneficial along with being environmentally friendly. For example, the adoption of zero-tillage for wheat production in the western, Indo-Gangetic plains reduced the farmers’ cost per hectare by 20% while increasing the average yields by 7% and net income by 28% (Aryal et al., 2015). It saved the farmers an average of up to 30 days of labor and 52 USD in land preparation costs per hectare. Also, the net returns increased each year from 2009-11 (the study period). Similarly in a maize-based production system in Mexico, when direct-seeded maize cropping with crop residue surface mulch was used for a period of five years, the soil organic content improved and doubled the yields (Scopel et al., 2005). To practice conservation agriculture, farmers need SAM support for land preparation, timely seeding and planting, weed control, integrated pest management, precision fertilizer application, harvesting, preparation for storage, and value addition. The SAM supports are also required for the entire food supply value chain like on-farm processing, transportation, and marketing. SAM should, thus, help in protecting the soil, air, and water, and in the efficient, optimal, and precise application of inputs like seeds, fertilizers, farmyard manure. At the same time, it should consume less energy. (FAO, 2017).

2.2.4. SAM for “Save and Grow”

(FAO, 2016a) The “Save and Grow” concept of FAO comprises of the following components integrated into farming systems:

- ♦ Conservation agriculture wherein farmers minimize soil disturbance, use mulching, crop rotation, crop diversification, integrate trees, livestock and aquaculture into the production system.
- ♦ Improve soil health by improving organic matter content and physical properties, reduce erosion, enhance water-use efficiency, improve fertility through nitrogen-fixing, and matching soil nutrient with crop demand.
- ♦ Use of diverse, complementary, and improved varieties of crops.
- ♦ Improving water-use efficiency through various techniques like furrow-irrigation, raised-bed planting, rainwater harvesting, dry-seeding of rice.
- ♦ Use of integrated pest management to reduce the use of pesticides.

An example of SAM following the paradigm of “Save and Grow” is the laser-guided tractor, operated using a custom hiring model, in the Indo-Gangetic plains. This technology has reduced water losses up to 40% for rice production, improved fertilizer efficiency, and enhanced yields by 5-10%. (Jat

[et al., 2009](#)). “*Save and Grow*” concept also requires SAM support across the entire value chain from production, post-harvesting, processing to distribution.

2.2.5. *Appropriate mechanization as a SAM approach*

The concept of “*appropriate mechanization*” talks about adapting machines to farm size and local agronomic context, making them user-friendly for the farmers, and suited to the low resource settings ([Krupnik et al., 2013](#); [Mottaleb et al., 2016](#); [Van Loon et al., 2018](#)). Some researchers argue that an *appropriate mechanization* lens can look at farm mechanization following the sustainability framework - economically viable, environmentally friendly, and socially acceptable ([Baudron et al., 2015](#); [Gómez and Van Loon, 2018](#); [Sims and Kienzle, 2017](#)). For example, researchers report that the operational costs of 2WT, an example of appropriate mechanization, are lower than those of tractors and animal traction. They also have lower emissions and produce less soil compaction. Due to their small size, their maneuverability in small and non-contiguous farms is brilliant. That implies the farmers don’t have to go for land consolidation, a social menace for smallholders. Due to their lower cost, these are also more economically accessible to the smallholders for both purchasing and renting. ([Baudron et al., 2015](#); [Lara-Lopez and Chancellor, 1999](#); [Tubiello et al., 2015](#); [Van Loon et al., 2020](#)).

2.2.6. *Mechanization for custom hiring*

Data from various sources show that there is a rising trend of consuming AM using custom hiring amongst smallholders across the globe (Example - ([Ranganathan, 2015](#); [Sims and Kienzle, 2016](#); [Van Loon et al., 2020](#)). This not only is a favorable situation for the farmers whose financial burden of purchasing, owning and maintaining AM is relieved ([Diao et al., 2018](#); [Mrema et al., 2014](#); [Sims and Kienzle, 2017](#)) but is also beneficial for generating rural employment (machine operator, maintenance, repair) and entrepreneurship (AM hiring service provider) opportunities by using the AM for on- and off-farm activities ([Sims et al., 2018](#)). A diversified service model (for both on- and off-farm activities) helps in the rapid recovery of AM cost, making it more affordable ([Baudron et al., 2015](#)). Due to increased access to AM through hiring, the problems of labor shortage and increasing labor costs can be resolved as well ([Biggs and Justice, 2013](#); [Gartaula et al., 2012](#)).

2.2.7. *Farm machinery manufacturing, marketing, and after-sale services*

([Mehta, C.R. et al., 2014](#); [Singh, 2006](#)) Farm machinery is manufactured by three categories of manufacturers: i) Village craftsmen and cottage industry, ii) Tiny and small scale-industry, iii) Organized farm machinery industry - medium-scale and large-scale industry. The village-level craftsmen and cottage industries are unorganized in nature and are mostly located in rural areas. They are mostly involved in the fabrication, repair, and maintenance of hand tools and traditional agricultural implements. Since they are located very close to the consumers, they can provide customized and personalized tools. When trained in the manufacturing of new tools and implements, they can help in accelerating the rate of adoption of mechanization due to their proximity with farmers. The tiny and small-scale industry serves a bulk of the AM in many countries like India and Bangladesh (Example - ([Gregg et al., 2020](#))). ([Gregg et al., 2020](#); [Mehta, C.R. et al., 2014](#); [Singh, 2006](#)) They manufacture locally adapted AM like a plow, cultivator, disc plow, seed drill, plant protection equipment, reaper harvesters, irrigation pumps, implements for tractors and 2WT, etc. They may lack technical expertise, good machines, and heat treatment facility leading to poor quality machinery output. They also usually don’t have an in-house R&D facility and depend largely on public institutions for technological support (Example - ([Krupnik et al., 2013](#))). ([Mehta, C.R. et al., 2014](#); [Singh, 2006](#)) They cannot create a large outreach in the absence of marketing networks and lack of standardization in parts and components. As a result, the farmers have to bring their machinery to the manufacturer for all sorts of repair and part replacements. The organized farm machinery industry consisting of

medium-scale and large-scale industry manufactures diesel engines, electric motors, irrigation pumps, sprayers and dusters, land development machinery, tractors, 2WT, post-harvest and processing machinery, and dairy equipment. They usually have good in-house R&D facilities and also look for technological support from external agencies. These might also have a global footprint. They have a well-established network for sales and distribution. They have the capability for product promotion, organize training programs, and provide after-sales services like repair, maintenance, spare parts, etc.

2.3. Challenges for smallholders to access mechanization

Some of the key challenges that smallholders face in accessing mechanization are as follows:

- ◆ Smallholders have tiny parcels of land and many times these are also non-contiguous. These are not well-suited to large machinery ([Krupnik et al., 2013](#); [Wolfenson, 2013](#)). Appropriate mechanization needs to be developed for a multitude of smallholder contexts based on soil, crop type, climate, and so on.
- ◆ AM ownership costs are beyond the financial reach of smallholders due to a lack of adequate credit facilities ([Clarke, 2000](#); [Mottaleb et al., 2016](#); [Sims and Kienzle, 2016](#)). Thus, ownership-based usage of AM is not economically viable for them. Appropriate custom hiring models need to be worked out for them. This will ease the financial burden of purchasing, owning, and maintaining AM for the farmers ([Diao et al., 2018](#); [Mrema et al., 2014](#); [Sims and Kienzle, 2017](#)).
- ◆ Smallholders' low levels of education come in the way of AM operation, maintenance, and repair ([Diao et al., 2018](#)). Adequate training and awareness facilities have to be created to overcome this lacuna.
- ◆ Rural mechanization in several developing countries is centrally planned and hence targeted to farmer cooperatives. These fail for smallholders due to the lack or absence of an allied service ecosystem consisting of manufacturing, supply, distribution, sales, and after-sales services ([Clarke, 2000](#); [FAO, 2008](#); [Pingali et al., 1987](#)). Hence, policy-level interventions are required².

2.4. Design challenges of mechanizing smallholder operations

The major design challenges identified by various researchers and agencies for farm mechanization of smallholders are as follows:

- ◆ Mechanization will be viable and acceptable for smallholders if it contributes towards enhancing land and labor productivity, expanding the area under cultivation, ensuring timeliness of operations, increasing profits, reducing costs, and drudgery ([Sims and Kienzle, 2006](#)).
- ◆ Smallholders own small and non-contiguous farms. Mechanization that can work efficiently and effectively in such contexts needs to be designed. The major challenge in this context is designing to build in economies of scale, especially for tasks like land preparation and harvesting ([Mehta, C. et al., 2014](#)).
- ◆ Designing mechanization considering the systemic and technological nuances for the rental and cooperative sharing market can aid in the percolation of farm mechanization. Many large global AM manufacturers have started exploring business models to cater to this opportunity. ([Adu-Baffour et al., 2019](#)).

² For example, in order to lay special emphasis on farm mechanization in India and to bring more inclusiveness, a dedicated Sub-Mission on Agricultural Mechanization (SMAM) for the XII Plan (2012-17) had been launched with an estimated outlay of US\$ 350 million for the plan period by Machinery & Technology Division (M&T), Department of Agriculture and Cooperation, Ministry of Agriculture of Government of India. SMAM put "Small & Marginal Farmers" at the core of the interventions with a special emphasis on "reaching the unreached", i.e. bringing farm mechanization to those villages where the technologies deployed are decades old. Besides, the mission also proposed to cater to "adverse economies of scale" by promoting "Custom Hiring Services" through "the rural entrepreneurship" model. The mission aimed at catalyzing an accelerated but inclusive growth of agricultural mechanization in India. Government of India, 2014b. Sub-Mission on Agricultural Mechanization - Operational guidelines (Twelfth Five Year Plan), in: Mechanization & Technology Division, Department of Agriculture, Cooperation and Farmers Welfare, Ministry of Agriculture and Farmers Welfare (Eds.). Government of India, Krishi Bhavan, New Delhi.

- ♦ A value chain approach to conducting agriculture involves looking at agriculture *from producer up to sale to the consumer* ([Sims and Kienzle, 2016](#)). When all involved stakeholders in the value chain are brought in together and work in tandem with each other, it produces higher returns ([Yaregal, 2014](#)), generates and sustains rural employment, reduces post-harvest losses, enhances the quality and integrates the smallholders into the market economy ([Sims and Kienzle, 2016](#)). Several studies have reported that mechanization can positively aid in achieving this value chain approach if designed considering all phases of the value chain: production, harvest, post-harvest, processing, and retailing ([Hilmi, 2013](#); [Sims et al., 2016](#); [Sims and Kienzle, 2009](#)).
- ♦ Technology adoption relies to a great extent on the presence and efficacy of parallel and supporting innovations and alliances from sectors like finance, governance and policies, and capacities ([Woltering et al., 2019](#)). Several pilot projects for AM development and adoption, funded by various agencies and governments, have failed to achieve scalability since the design of the program had not considered the same at the beginning ([Cooley and Kohl, 2016](#); [International Institute of Rural Reconstruction, 2000](#); [Organization and ExpandNet, 2011](#)). Thus, the designers of these projects must plan for scaling of the project from the very beginning following a systems approach wherein they examine and bring together overlapping economic, social, technical, and political systems ([Woltering et al., 2019](#)).
- ♦ Mechanization design should accompany design for support service ecosystem catering to services like local manufacturing, training, hiring service, supply and distribution, sales, and after-sales services. Also, other support system components like credit and financial support for the purchase of farm machinery, certification, and accreditation needs require strong attention. ([Chisawillo, 2015](#))
- ♦ Mechanization should follow SAM guidelines to minimize land degradation and optimize agricultural input use. The systemic approach of “Save and Grow” which integrates conservation agriculture, soil health-enhancing techniques, water-efficiency improvement, and integrated pest management strategies is the key to mechanization design. ([FAO, 2016a](#); [Sims and Kienzle, 2016, 2017](#)).
- ♦ Mechanization design (hand/ draught animal/ power-operated) should not be seen as upward progress from hand to animal to power but as the best possible combination package that mechanizes activities to produce productivity enhancement and drudgery reduction ([Van Loon et al., 2015](#)). The selection of the options should be made using a participatory process involving all key stakeholders: farmers, AM manufacturers and dealers, service providers, supply chain stakeholders, academia, extension service providers, and policymakers ([Sims and Kienzle, 2016](#)). It has also been observed that farmers (or hiring service providers) find it difficult to make appropriate choices when given a multitude of options ([Government of Punjab, 2005](#); [Singh, 2009](#)). Hence, apart from providing them a platform to voice their opinion and choose, they should also be provided with training platforms to choose farm power and machinery best suited to their context ([Sims and Kienzle, 2016](#)).
- ♦ Mechanization design should follow a participatory technology development approach involving manufacturers, researchers, and other stakeholders like farmers, dealers, service providers, supply chain stakeholders, extension service providers. This will, on the one hand, develop local capacity towards technology development ([Sims and Kienzle, 2017](#)) and on the other create solutions that are more locally situated.
- ♦ Mechanization design should look at mechanization as an investment for farmers and stakeholders involved in the entire value chain. These stakeholders can be the manufacturer, service providers, machine operators, maintenance providers, spare parts distributors, and so on. Thus, it should be capable of generating income and profits for all. Apart from the economic viability, the design process should look for avenues for generating social capital like drudgery reduction, machinery as a status symbol ([Houmy et al., 2013](#)).

- ♦ Mechanization design should consider design for training for both technical know-how (like machine operation, maintenance, manufacturing) and business management skills for the stakeholders ([Sims and Kienzle, 2016](#)).
- ♦ The feminization of agriculture is a global trend. Designing mechanization to suit the ergonomic needs of women as operators need focus ([Dewangan et al., 2008](#)). Another focus can be designing mechanization to reduce the drudgery of women ([Erdewijk and Danielsen, 2015](#); [International Fund for Agricultural Development and Japan Official Development Assistance, 1998](#); [Sims and Kienzle, 2006](#)).
- ♦ Mechanization considering local manufacturing can offer the advantage of being close to the center of consumption and hence can adapt solutions to cater to local needs. It also implies better spare parts and maintenance support. In this case, the design process also needs to incorporate capacity building strategies for the local manufacturer to build in safety standards and rationalization of manufacturing processes. ([Gregg et al., 2020](#)).

2.5. Thesis problem definition

From the discussion presented so forth, it is evident that the smallholders of developing countries are key to global food security. To attain sustainable development of smallholder farming, AM is a key input. Achieving sustainable development in the agricultural sector also needs attention to SAM. SAM needs a design process that follows a PSS-oriented design approach³ (the pros and cons of a PSS approach is further elaborated in section [4.1](#), [4.3](#) and [4.4](#)) that connects the “*technical, economical and engineering aspects*” of machinery design with the allied service ecosystem. Thus, AM and its associated service ecosystem design need due consideration to the following three aspects:

- ♦ “*Sustainability over the entire life cycle, i.e., from design, development, manufacturing, sale, use, repair, and maintenance to disposal.*”
- ♦ *Appropriate mechanization along with strategic business model (considering its associated service ecosystem) development to make them accessible to the farmers.*
- ♦ *Sustainability on all three dimensions simultaneously.”* ([Banerjee and Puneekar, 2020](#))

In this thesis, designing for SAM for small farms of developing countries implies sustainability-orienting design of AM and its associated service ecosystem design following a PSS approach.

2.6. Research objectives and research questions

Thus, the research objectives of this thesis are:

- ♦ To identify existing sustainability-orienting design supports from the domain of agriculture and product design for designing SAM.
- ♦ To assess the efficacy of the identified sustainability-orienting design supports in addressing sustainability holistically - simultaneously considering social, economic and ecological dimension - for the design of SAM for small farms of developing countries throughout its lifecycle, i.e., from design conceptualization, development, manufacturing, sale, use, repair and maintenance to disposal.
- ♦ In case, the efficacy is inadequate, to formulate a possible sustainability-orienting design support for the given context.

³ PSS design is a design approach where a product and its associated services are designed together as a system offering to satisfy customers’ needs. Changing markets and recognizing that when services are bundled with products as an offering, profit margins are higher, is leading to PSS’s push in the otherwise traditional manufacturing-oriented companies Sawhney, M., Balasubramanian, S., Krishnan, V.V., 2003. Creating growth with services. MIT Sloan management review 45(2), 34-44.. Thus, Goedkoop, M.J., van Halen, C.J., te Riele, H.R., Rommens, P.J., 1999. Product service systems, ecological and economic basics. 1999. VROM: Hague, the Netherlands. defined a PSS as a “*marketable set of products and services capability of jointly fulfilling a user’s needs.*”

- ♦ To assess the designed sustainability-orienting design support's effectiveness in use and operationalization during the design conceptualization phase of SAM for small farms of developing countries.

Thus, the following research questions were set to be answered.

2.6.1. Research question 1

Do current sustainability-orienting design supports address sustainability concerns for the design of SAM for small farms of developing countries

- ♦ Considering the social, economic, and environmental dimension concurrently; and,
- ♦ Throughout the life cycle, i.e., from design, development, manufacturing, sale, use, repair, and maintenance to end-of-life?

2.6.2. Research question 2

What could be a possible sustainability-orienting design support for the design of SAM for small farms of developing countries that take into account:

- ♦ The pros and cons of the existing sustainability-orienting design supports from related domains; and
- ♦ Addresses a holistic picture of sustainability, including its three dimensions (social, economic, and environmental), in the given context?

2.6.3. Research question 3

How effective is the proposed sustainability-orienting design support in use and operationalization during the design conceptualization phase of SAM for small farms of developing countries?

For answering research question 3, a statistical analysis of the evaluation results was conducted. Hypothesis for the same is presented in [Chapter 7](#).

2.7. Scope of the thesis

Although SAM encompasses all typologies of AM, small hand tools to sophisticated powered equipment, this thesis restricts its scope to AM that consist of several sub-assemblies and have a significant amount of embodied material and energy. Thus, these AM have a significant impact on all three dimensions of sustainability. Also, these AM should be expensive for individual ownership and have only sparse utilization in individual ownership. A custom hiring mode of consumption of the AM should offer a high density of usage and make it more cost-effective for consumption. Thus, simple machines like hand-tools or simple battery-operated tools with low environmental footprint and machines with a heavy density of usage which have to be consumed on ownership basis are out of the scope of the thesis.

3. Research methodology

The thesis uses the approach of Design Science Research Methodology as developed by (Peffer et al., 2006) and improvised by (Gleasure et al., 2012; Reubens, 2016). This chapter details out the methodology, the rationale for selecting it, the research stages of the thesis, and its presentation in the thesis chapters.

3.1. Design Science Research methodology

DSR is a design-oriented research approach, first developed in the context of Information Systems research with a three-fold objective:

1. “provide a nominal process for the conduct of Design Science research,
2. build upon prior literature about Design Science in Information Systems and reference disciplines, and
3. provide researchers with a mental model or template for a structure for research outputs.” (Peffer et al., 2006)

Several research studies have established the principles, guidelines, framework, and context for DSR (Iivari and Venable, 2009; Nunamaker Jr et al., 1990; Venable, 2006; Von Alan et al., 2004; Walls et al., 1992). DSR follows the iterative design process, consisting of research, analysis, synthesis, and evaluation until the intended outcome is realized (Plomp and Nieveen, 2013). Thus, it is a research methodology wherein the researcher while inventing or building new artifacts to cater to some real-life problems, creates a new reality rather than just explaining the existing reality (Iivari and Venable, 2009). The context of DSR is, thus, theory-building by solution or technology invention using naturalistic and artificial evaluation methods (Venable, 2006). Figure 3.1 below represents this theory building framework and context of DSR as represented by (Venable, 2006).

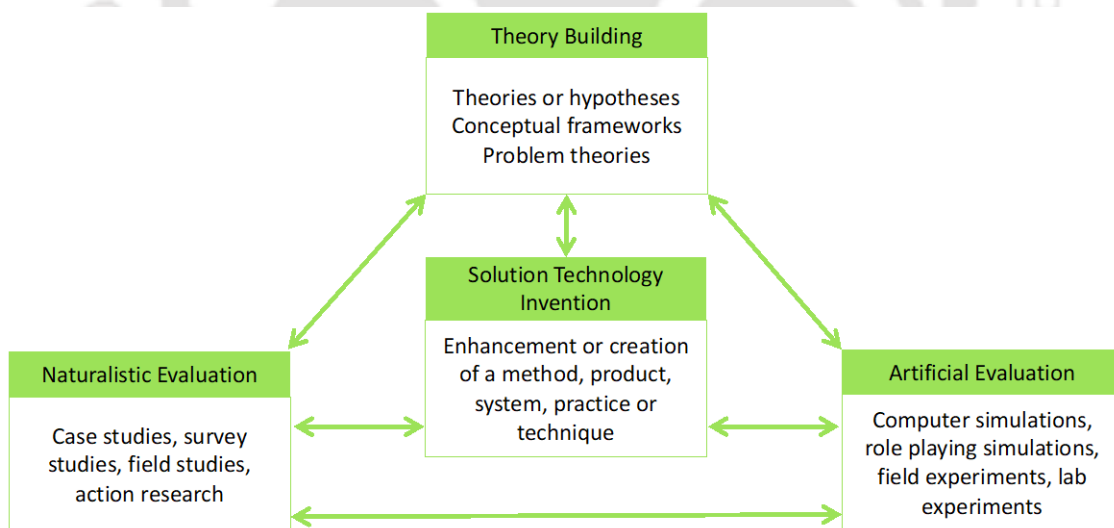

Figure 3.1. Framework and Context of DSR as represented by (Venable, 2006).

The nominal process sequence of DSR consists of seven iterative stages that mimic the iterative design process: 1. Problem identification and motivation; 2. Kernel knowledge 3. Defining the objectives of a solution; 4. Design and development; 5. Demonstration; 6. Evaluation; and, 7. Communication (Geerts, 2011; Peffer et al., 2007; Reubens, 2016). Table 3.1 below elaborates on the activities at each of the seven stages.

Table 3.1. Elaboration of the DSR process steps ([Geerts, 2011](#); [Peffer et al., 2007](#))

Source for Sr. No. 1 - 7 excluding 2: ([Geerts, 2011](#)), Source for Sr. No. 2: ([Reubens, 2016](#)).

	Stage	Activity Description
1	Problem identification & motivation	Research problem definition, its relevance, and current solutions and their weaknesses and strengths. Justify the need for the solution.
2	Kernel Knowledge	Identify existing knowledge and information.
3	Define the objectives of a solution	Define the objectives in terms of feasibility, technical requirements, human-centered design requirements, and other objectives specific to the problem definition.
4	Design and development	Design a solution that solves the problem. Construct a theoretical construct/ model/ method / instantiation as a research contribution.
5	Demonstration	Demonstrate the solution's use. Demonstrate the solution's use in one or multiple instances of the specific problem class selected.
6	Evaluation	Measure the effectiveness and efficiency of the solution.
7	Communication	Communicate the contexts, results, and novelty to researchers and other relevant audiences.

3.2. The rationale for selection of DSR

The rationale for using DSR in this thesis is two-fold:

1. ([Plomp and Nieveen, 2013](#)) DSR focusses on designing interventions for a real-world problem and need context, improves them iteratively, and the evaluations of the iterations help in building theory that can be used by other designers for similar design contexts. The theory developed can be in the form of design guidelines, checklists, and principles ([Barab and Squire, 2004](#); [Herrington et al., 2012](#); [Plomp and Nieveen, 2013](#); [Van den Akker, 1999](#)). We have a similar context in hand. We use a real-life redesign case study (as explained in [Chapter 5](#)), to determine the efficacy of existing sustainability-oriented design methodologies and tools in designing for SAM for small farms of developing countries. While redesigning the solution, we build a design framework and a set of design guidelines that can be used by other designers for similar design contexts. We then evaluate and further refine the design framework and the set of design guidelines using similar design contexts.
2. The stages of DSR and action research have a high degree of similarities. Action research is a participatory research methodology wherein the researchers work closely with the system stakeholders to achieve the desired results ([McMillan, 1996](#)). Some researchers ([Järvinen, 2007](#)) argue that DSR and action research are similar and interchangeable while others ([Geerts, 2011](#); [Reubens, 2016](#)) see them as different. The research presented in this thesis aims to contribute towards design theory that can be used by other designers for real-life problems with similar typology, i.e., design of SAM for small farms of developing countries. According to ([Plomp and Nieveen, 2013](#)), that is an essential characteristic of DSR while in action research generation of theories or design principles that can be used by other designers for real-life problems with similar typology is not a priority. Also, in DSR, the research targets a specific class of problems and its stakeholders ([Venable, 2006](#)) while in action research, the research aims at a specific problem context and its stakeholders. The aim of our research was a specific class of problems - design of SAM for small farms of developing countries.

3.3. Research stages of thesis

Following the spirit of the DSR methodology, the research work presented in this thesis targets to design, develop, and test a solution (BP) to a real-world problem (*bed planting in small farms of South Bangladesh*) following an iterative design process. During this process, a theoretical framework (*D-SAM*

and G-SAM) for designing interventions for the same class of problems (SAM for small farms of developing countries) is devised. This theoretical framework can be thus, used for a broader set of scenarios in the same class of problems (tested further on eight other SAM design projects for small farms of two developing countries). The following paragraphs elaborate further on the research stages of the thesis.

Stage 1 - Problem identification & motivation

As discussed in [Chapter 2](#), the problem class being addressed in this thesis is the designing of SAM for small farms of developing countries. Chapter 2 elaborates on the rationale behind the selection of the problem class, its relevance, and current solutions and their weaknesses and strengths.

Stage 2.1 – Kernel knowledge

[Chapter 4](#) identifies existing sustainability-oriented design supports from the domain of agriculture and product design. It argues the rationale behind the selection of a methodology for S.PSS design (MSDS) and toolkit for LCD (ICS) for design of SAM.

[Chapter 5](#) tests the efficacy and sufficiency of the methodology for S.PSS design and toolkit for LCD for design of SAM on a real-world problem. The real-world problem being tackled here is, to design a SAM which can reduce the manual labor and costs involved in bed planting of crops in small farms of South Bangladesh, a developing country.

Stage 3.1 – Define the objectives of a solution

In [Chapter 5](#), the application of MSDS and ICS toolkit to the real-world problem identified three major gap areas in the existing design supports. Thus, the objective for a solution, in this case a design support for the design of SAM for small farms of developing countries, was set. The design objectives were to fill the product design gap in MSDS, add a checklist to assess and design for sustainable agricultural outcome and introduce participatory design processes at appropriate stages of MSDS.

Stage 2.2 – Kernel knowledge

To fill the gap related to the need for an assessment and design support for achieving sustainable agricultural outcome, a literature review was conducted (presented in [Chapter 5](#)). The review resulted in formulation of a methodology to derive the assessment and design support, called SAC checklist.

Stage 4.1 – Design and development

The theorizing process resulted in the refinement of the MSDS stages and processes and the formulation of the SAC checklist ([Chapter 5](#)) for designing SAM for small farms of developing countries for custom hiring.

Stage 5.1 – Demonstration

Next, those are used for the design of the real-world challenge, 2WT based BP to test their efficacy in [Chapter 5](#).

Stage 4.2 – Design and development

Post the demonstration on the real-world problem, [Chapter 6](#) summarizes the D-SAM framework I, as derived from the experience of applying the modified MSDS and the SAC checklist. D-SAM framework I is a design methodology for the class of problem – design for SAM for small farms of developing countries.

Stage 6.1 – Evaluation

Next, [Chapter 6](#) measures the effectiveness and efficiency of the SAC checklist and the D-SAM framework I on the real-world intervention case.

Stage 3.2 – Define the objectives of a solution

The objectives for refining D-SAM framework I and SAC checklist to obtain the D-SAM framework II and G-SAM were set next in [Chapter 6](#).

Stage 2.3 – Kernel knowledge

Thereafter, [Chapter 6](#) presents a review of literature on indicator-based sustainability assessment approaches from the field of agricultural practices which are used to derive G-SAM.

Stage 4.3 – Design and development

[Chapter 6](#) concludes with the design and development of the sustainability-orienting design framework II (D-SAM) & sustainability assessment and design guidelines (G-SAM).

Stage 5.2 – Demonstration

[Chapter 7](#) presents the demonstration of D-SAM framework and G-SAM on multiple instances of the given class of problem, i.e., design of SAM for small farms of developing countries.

Stage 6.2 – Evaluation

Through the application of G-SAM on multiple instances of the problem class, [Chapter 7](#) evaluates and validates G-SAM.

Stage 7 – Communication

[Chapter 8](#) presents the key research findings, contributions of the thesis, limitations and future research.

[Figure 3.2](#) describes the research stages following the iterative DSR methodology and its organization in the thesis chapter.

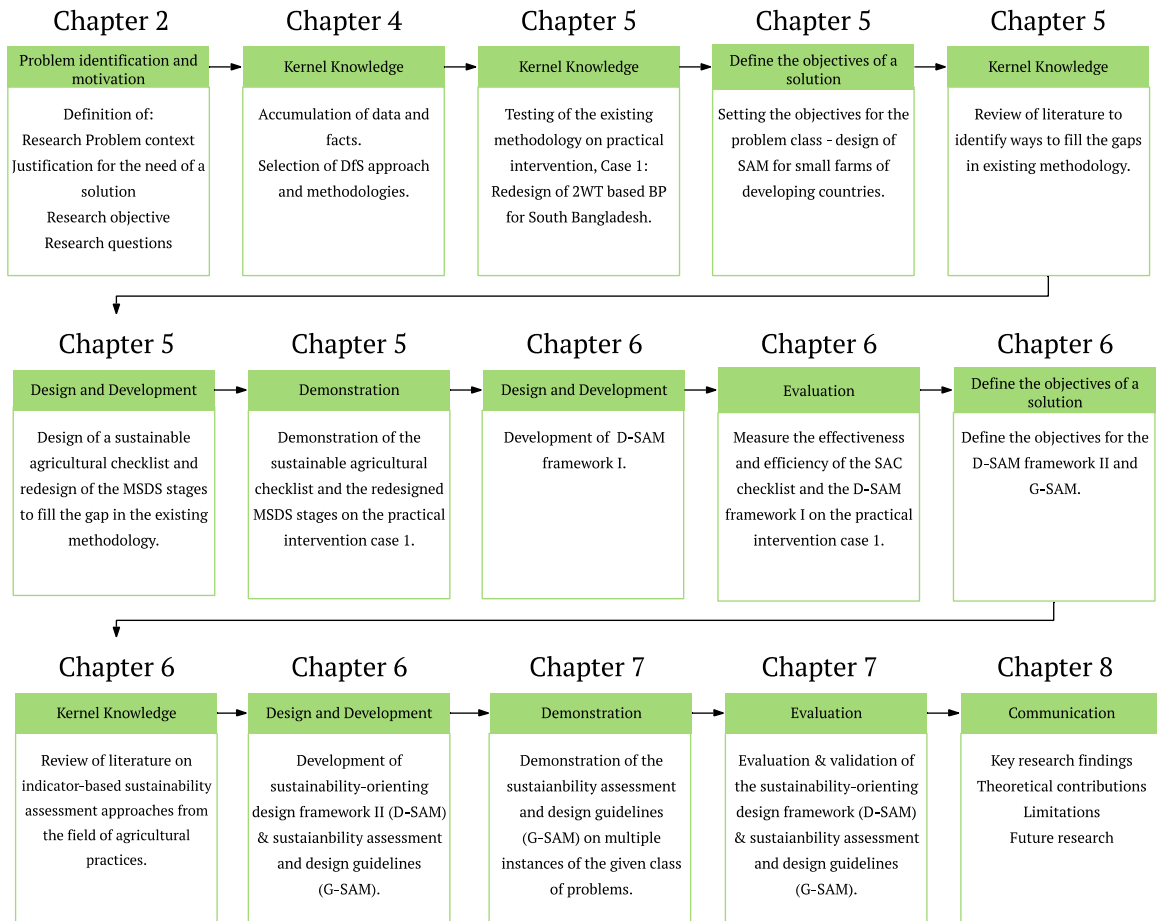

Figure 3.2. Diagrammatic representation of the research stages of the thesis.

4. Sustainability-orienting design approaches

Sustainability is argued to be achieved at the confluence of three dimensions: social, economic, and environmental. That makes DfS a wicked and complex problem. Thus, the designer needs to deal with complex, interrelated issues that require cross-disciplinary and trans-disciplinary knowledge and expertise (Jerneck et al., 2010). To aid in this complex design process, a designer can use a set of design supports to aid in the design process. Design support can be a design methodology, set of methods, guidelines, and tools (Blessing and Chakrabarti, 2009). The authors define the four types of design support as:

- ♦ Design approach or methodology, as *“an overall framework for doing design.”*
- ♦ Design methods, as *“a sequence of activities to be followed in order to improve particular stages of the design process and specific tasks within these stages.”*
- ♦ Design guidelines, as *“a set of rules, principles, and heuristics that are useful to follow in attaining some design objectives.”*
- ♦ Design tools, as *“hardware and software for supporting design, based on some design approach, method or set of guideline.”*

This chapter sets the stage for identifying existing design supports and the rationale for selecting the most applicable ones.

From the discussion presented in Chapter 2, it is evident that SAM needs a design process that follows an S.PSS design approach that connects the *“technical, economical and engineering aspects”* of machinery design with the allied service ecosystem. Thus, AM and its associated service ecosystem design need three aspects: (1) sustainability over the entire life cycle and (2) on all three dimensions, and (3) designing the machine along with its associated service ecosystem. This chapter summarizes the various sustainability-orienting design supports from the domain of Design and AM or mechanization. Thus, it sets the stage for answering research question 1:

Do current sustainability-orienting design supports address sustainability concerns for the design of SAM for small farms of developing countries

- ♦ Considering the social, economic, and environmental dimension concurrently; and,
- ♦ Throughout the life cycle, i.e., from design, development, manufacturing, sale, use, repair, and maintenance to end-of-life?

Thus, this chapter first elaborates on the evolution of sustainability approaches within the domain of Design. The discussion concurs to the need for SAM design following an S.PSS approach as suggested by FAO and presented in Chapter 2. The investigation results in selecting a life cycle design toolkit and an S.PSS methodology for further efficacy evaluation (presented in Chapter 5) for the context of designing SAM. After that, we present research on sustainability-orienting design supports from the domain of agricultural mechanization.

4.1. Evolution of sustainability approaches within the domain of Design

The terms *“sustainability”* and *“sustainable”* made their entry into the Oxford English Dictionary only in the second half of the 20th century (Du Pisani, 2006). *Our Common Future*, the report published

Kernel Knowledge

Accumulation of data and facts.

Selection of DfS approach and methodologies.

in 1987 by the UN World Commission on Environment and Development, set a turning point in the discussions around *sustainability* with its definition of *sustainable development* – “a development that meets the needs of the present without compromising the ability of future generations to meet their own needs” (Brundtland Commission, 1987). (Vezzoli et al., 2014) However, discussions on sustainability had emerged around the mid-1960s as environmental issues due to the time's production-consumption system disrupted the ecological equilibrium and caused damage to the environment. The next two decades saw a rise in scientific works, international debates, public opinion intensification, and studies in this arena. Various policy level interventions based on *Polluter Pays Principle* were thus, formulated. The UNEP and other agencies started emphasizing the importance of cleaning up the production processes by redesigning manufacturing processes and products. The redesign's aim was pollution and waste reduction and thereby the risk they pose to humans and the environment. The idea that environment and development need to be considered concurrently led to the coining of various terminologies like “environment and development,” “development without destruction,” “environmentally sound development,” and “eco-development” (Mebratu, 1998). The International Union for the Conservation of Nature, along with World Wildlife Fund for Nature and UNEP, published a book, which defined sustainable development as “improving the quality of human life within the limits of capacity to protect the ecosystems” (UNEP et al., 1991). This definition, along with the Brundtland Commission's definition, puts sustainable development at the confluence of practices beneficial to both the humans and the ecosystem. The Brundtland Commission's definition of sustainable development contains two key concepts:

- ♦ The first being that of “needs” and emphasizes to give overriding priority to the needs of the poor.
- ♦ The second being that of “limitations imposed by the state of technology and social organization on the environment's ability to meet present and future needs.”

Thus, it brings forth the connection between “poverty alleviation, environmental improvement, and social equitability through sustainable economic growth” (Mebratu, 1998). Hence, the need for a systemic view to sustainability, involving the social, economic, and environmental dimensions concurrently, cropped up. In a further development, the *Sustainable Consumption Unit* was set up under UNEP in May 2000 (United Nations, 2000). That was in response to the realization that despite the signs of progress made by the industries and the industrialized world in developing and adopting sustainable production processes, global consumption exceeds the Earth's capacity to supply resources and absorb the wastes and emissions produced. Consequently, the focus shifted towards understanding consumption and strategizing DfS by moving the consumption-production system towards a higher degree of sustainability. (Vezzoli et al., 2014).

Thus, the changes in intervention strategies to achieving sustainability can be mapped as from “intervention after process-caused damages” to “intervention in processes” so that damages can be minimized, to “intervention in products and services” so that damaging processes can be avoided, and after that, to “interventions in consumption patterns” so that damaging consumption patterns can be avoided (ibid). Accordingly, the focus of DfS has been four folds (Charter and Tischner, 2001; Karlsson and Luttrupp, 2006; Rocchi, 2005; Ryan and Fleming, 2004; Vezzoli et al., 2014; Vezzoli and Manzini, 2008):

1. Designing with a *selection of resources with low environmental impact*, which includes strategies like designing with materials, processes, and energy resources with low environmental impact, biodegradability or renewability, for ease of identification (for end-of-life treatment), for the elimination of toxic materials and emissions, and waste management and optimization. (Vezzoli et al., 2014). However, design for recycling, reuse, or energy recovery suffers from various economic and technological limitations. This approach also provides insights only on the environmental aspects and does nothing about the social and economic aspects that determine consumption

patterns and hence the ultimate environmental impact. Material databases like Cambridge Engineering Selector & 3D modeling software like SolidWorks have options to select materials with an idea about their carbon footprint and embodied energy. One can compare various materials & select the one with desired physical, chemical, mechanical, electrical, optical & environmental impact parameters.

2. Designing with a *Life Cycle Design* or *Eco-design* approach where the design approach is not the design of a product only but for a product's entire life cycle from extraction of raw materials, manufacturing, sale, use, repair, and maintenance to end-of-life. Also, it includes design strategies where a product's environmental sustainability is viewed from a functional perspective, to begin with, rather than just the embodiment. ([Brezet and Van Hemel, 1997](#); [Heiskanen, 2002](#); [Keoleian et al., 1993](#); [Ryan, 2003](#); [Sun et al., 2003](#); [Van Hemel, 2001](#); [Van Nes and Cramer, 2006](#)). This strategy aids in identifying the stages of a product's life cycle with the highest impact and designing interventions to counter the same. It is supported by LCA tools, which quantify the environmental impact. Thus, two competing product solutions can be compared against each other in terms of environmental impact, and appropriate design choices can be made. LCA cannot identify environmental sustainability problems in products ([Park and Tahara, 2008](#)). The implementation of this approach meets with impediments in how the traditional product supply chains are designed. In this approach, the producer has reasonable control over the production side and can ensure environmental performance as per design. The consumption side and end-of-life scenarios are approximations only, and the producer cannot guarantee environmental performance as per design after the product enters the consumption phase. LCA values change with spatial variations and, thus, depend heavily on the availability of location-specific databases. Like the previous approach, it also provides insight only on the environmental aspects and does nothing about the social and economic aspects. Several LCA software (discussed in detail in [Table 4.2](#) and section [4.2](#)) like SimaPro and Gabi help calculate the life cycle impact of products and processes. ICS toolkit, EDIP (Environmental Design Strategies, Environmental Specification, Environmental Design, and Rules), ECODesign tool are examples of qualitative tools that aid in LCD ([Table 4.2](#)).
3. Designing for *eco-efficient PSS*, where a combination of products and services is designed to meet a particular customer demand related to their needs & desires. It is referred to as designing for a *satisfaction unit* ([Vezzoli et al., 2014](#)). Eco-efficient PSS is defined as “*an offer model providing an integrated mix of products and services that are together able to fulfill a particular customer demand (to deliver a ‘unit of satisfaction’)* based on innovative interactions between the stakeholders of the value production system (satisfaction system), where the economic & competitive interest of the providers continuously seeks environmentally beneficial new solutions” ([Vezzoli et al., 2014](#)). Thus, here DfS follows a systems approach. The system is designed and incentivized to promote sustainable consumption choices ([Tukker, A. and Tischner, U., 2006](#)). It takes into account all three dimensions of sustainability, social, economic, and environmental concurrently. However, each dimension can be allocated varying degrees of priority based on the problem context and stakeholders' demand. Since the design approach tries to design offer models where being sustainable is in the producer's economic interest, economic value creation is not dependent on increased resource consumption ([Baines et al., 2007](#)). Eight different PSS typologies have been identified with varying degrees of sustainability potential ([Tukker, 2004](#)). In case the manufacturer retains the ownership of the products and delivers its functions to the customer on-demand, paid at per unit of the result, they have the highest economic interest in optimizing resource consumption ([Halme et al., 2004](#)). This model of consumption without the need for ownership for the consumers makes it very suitable for designing for the economically weaker sections of the society (Example - ([Emili et al., 2016](#)), ([Santos et al., 2014](#))). It entails the need for product design along with its business model design. Together they “*may act as business opportunities to facilitate the process of social-economic development in emerging and low-income contexts - by jumping over or by-passing the stage of individual consumption/ ownership of mass-produced goods - towards a “satisfaction-based” and low-resource intensive advanced service economy*” ([UNEP, 2002](#)). This approach has further evolved into a sustainable PSS (S.PSS)

oriented design approach defined as: “an offer model providing an integrated mix of product and services that are together able to fulfill a particular customer demand (to deliver a ‘unit of satisfaction’) based on innovative interactions between the stakeholders of the value production system (satisfaction system), where the economic and competitive interest of the providers continuously seeks both environmentally and socio-ethically beneficial new solutions” (Vezzoli et al., 2014). For this approach, few tools (Appendix 3) (example - MEPSS: Methodology for Product Service System development (Van Halen et al., 2005), SusProNet: Sustainable Product-Service co-design Network (Tischner and Verkuijl, 2002), MSDS: Methodology for System Design for Sustainability (Vezzoli et al., 2014)), case-study and guiding models exist, and further work for different contexts is required. The critical challenge of this DfS approach is the complexity of the design process due to the involvement of several stakeholders and the systemic nature of the problem, making designing, testing, and implementation a challenge (Ceschin, F., 2013; Tukker, A. and Tischner, U., 2006; Vezzoli et al., 2015). In order to adopt a PSS, customers might have to change their consumption behavior (Catulli, 2012; Mont, 2004b), companies have to re-gear their organizational machinery (Martinez et al., 2010; Mont, 2004b), and regulatory norms have to be reworked (Mont and Lindhqvist, 2003).

- Designing for *social equity and cohesion* where aspects like *just society*, concerns for fundamental rights and diversity, creating equal opportunities, and empathic, kind, and compassionate society drives the design thought process. Various approaches like *Design for the Base of the Pyramid* (Cruel and Diehl, 2006; Dos Santos et al., 2009; Kandachar, 2010), life cycle assessment extended to social impact (Weidema, 2005), PSS for social equity and cohesion focus or *System Design for Sustainability* (Kandachar, 2010; Soumitri and Vezzoli, 2002), designing PSS with *Sufficiency Economy Philosophy* (Fusakul and Siridej, 2010), *Design for Social Enterprise* (Santos dos, 2008), *Design for Distributed Economy* (Johansson et al., 2005), *Grassroots to Global* (Gupta, 1999, 2010) fall under this umbrella. It is an emerging frontier for DfS for theoretical development, implying very few design methodologies and tools to aid designers in their problem-solving process. Thus, very few models for the practical application exist, and there are very few curricular courses. Several of these approaches need a designer to design for social innovation or social innovation in conjunction with technical innovation. It usually emerges as an enormous challenge to tackle in terms of design, resource and communication management, and time required to create such a change.

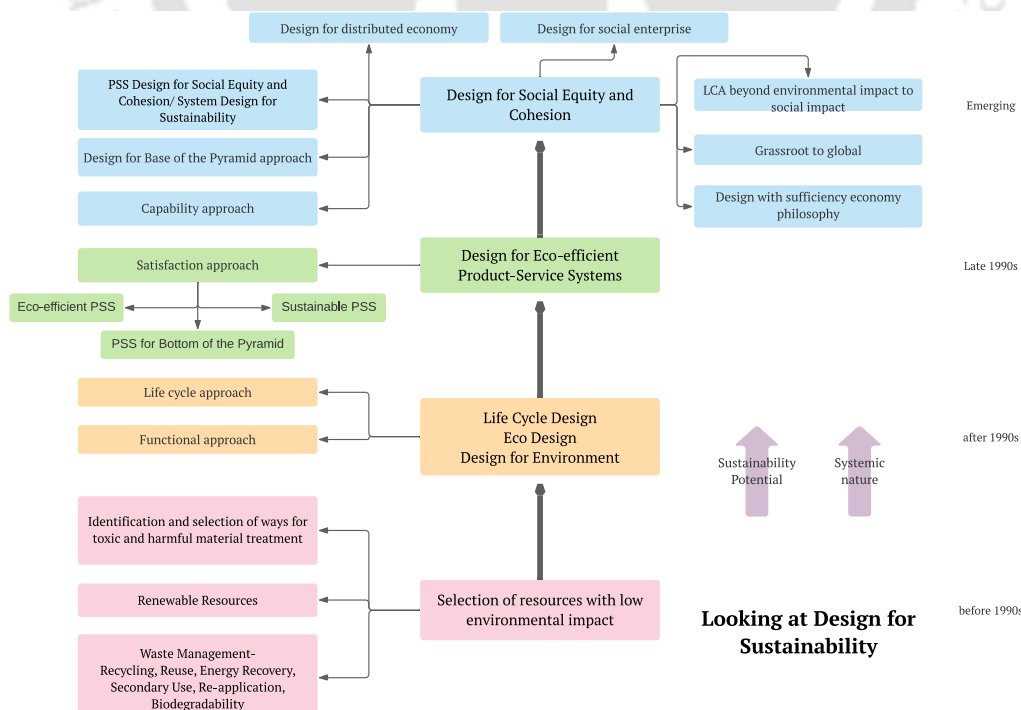

Figure 4.1. Evolution of DfS approach.

The four approaches mentioned above are not in chronological order and follow varied penetration levels in different country contexts. For example, designing with low impact resources and life cycle approach is well established both in pedagogy and practice in the industrialized European context, while the eco-efficient PSS approach is gaining momentum slowly (Vezzoli et al., 2014). On the other hand, emerging countries and contexts have prioritized designing for social equity and cohesion (Santos dos, 2008). However, few theoretical models have been developed for this design approach (Vezzoli et al., 2014). The sustainability potential of the four design approaches mentioned above increases from bottom to top. Also, the systemic nature of the design process increases from bottom to top. Figure 4.1 summarizes the four DfS approaches.

Ceschin and Gaziulusoy (2016) classified the existing sustainability-orienting design approaches into four levels of innovation: *product*, *PSS*, *spatio-social*, or *socio-technical system*. Table 4.1 below list the various sustainability-orienting design approaches, their classification on the level of innovation they target, and their focus area. Thus, the *selection of resources with low environmental impact* and *life cycle design* (ecodesign or design for environment) come under the product innovation level. Some of the design approaches at that level are *green design*, *ecodesign*, *emotionally durable design*, *design for sustainable behavior*, *cradle-to-cradle design*, *biomimicry design*. The design approaches *eco-efficient PSS*, *sustainable PSS*, and *PSS for the bottom of the pyramid* calls for innovation at the *PSS* level. The design approaches under the approach *design for social equity and cohesion* falls under the *spatio-social* or *socio-technical system* level of innovation. The authors map the sustainability potential of design approaches on two dimensions: technical/ people, insular/ systemic. A design approach's sustainability potential increases as the focus shifts from merely technology-oriented incremental innovations to sustainability-oriented innovations targeting socio-technical challenges. In this context, the users' choices, behaviors, and practices need to be given due diligence. The sustainability potential improves as the firm shifts its focus from merely satisfying internal issues to creating an impact on the broader socio-economic system while engaging other stakeholders in the process. Thus, the product innovation level, which is more insular and oriented towards technological innovation, has lower sustainability potential than the other three levels. The PSS, spatio-social, and socio-technical system innovation levels work more on socio-technical challenges and target a systems approach. According to Adams et al. (2016), who studied sustainability-oriented innovations for businesses, identified three dimensions: technical/ people; insular/ systemic; stand-alone/ integrated that can be used to study the sustainability potential of a business. The authors present evidence that when a business follows a more systemic approach by bringing together a set of providers who together produce and distribute new PSS aiming at positive *societal change*, the sustainability potential of the business is the highest. In this context, the focus is on creating a network where sustainability is achieved collaboratively as a "set of actions that shift a system – a city, a sector, an economy – onto a more sustainable path" (Draper, 2013).

Table 4.1. Sustainability-orienting design approaches classified into innovation levels. Source - (Ceschin and Gaziulusoy, 2016)

Innovation Level	Design Approach	Focus
Product Innovation	Green Design	Reducing the environmental impact of an individual product by redesigning singular qualities following the reduce-reuse-recycle principles.
	Ecodesign	Reducing environmental impact through life cycle redesign of products.
	Emotionally durable design	Discouraging users from discarding products and encouraging for prolonged usage through emotional attachment creation with the product.

	Design for sustainable behavior	Encouraging people to adopt sustainable behavior and discard the unsustainable ones.
	Cradle-to-cradle design	Designing to close the technical and biological loops to keep regenerating resources.
	Biomimicry design	Designing with inspiration from nature at the form, function, and system-level wherein nature is the “model, measure and mentor.”
	Design for the base of the pyramid	Designing market-based interventions to improve the lives of the base of the pyramid.
PSS Innovation	PSS design for eco-efficiency	Design of PSS offerings where the providers are on the lookout for environment-friendly solutions that provides them an economical and competitive advantage.
	PSS design for sustainability	Design of PSS offerings where the providers are on the lookout for socio-ethical and environment-friendly solutions since it provides them an economical and competitive advantage.
	PSS design for the bottom of the pyramid	As above and applied to the base of the Pyramid market.
Spatio-social Innovation	Design for social innovation	Aiding with design, development, and scaling of social innovations.
	Systemic design	Design of local systems so that the waste from one process of the system becomes the input for another process.
Socio-technical System Innovation	Design for system innovations and transitions	Strategic design of socio-technical systems.

Thus, an analysis of the evolution trajectory of sustainability-orienting design approaches and strategies concur with the need to design SAM as an S.PSS. The following sections elaborate on existing literature on the life cycle and *satisfaction unit*-based design of SAM and the rationale for selecting an approach.

4.2. Product innovation - life cycle-based assessment and design approach for SAM

LCA is a quantitative method (Alting, 1995) that can measure the environmental impact of a product's life cycle from production, distribution, use, to disposal (Vogtländer, 2012). Several software tools, like SimaPro and GaBi, help in conducting LCA. LCD, also called as ecodesign or design for environment, is a design methodology which focusses on designing the stages of the life cycle of a product (rather than only the product) and for the satisfaction of a function (Vezzoli and Manzini, 2008). LCD is a product system design process covering a product's life cycle from pre-production, production, distribution, use, to disposal. LCD aims to integrate the environmental aspect into a product's design throughout its life cycle to obtain an optimized solution. Thus, the LCD approach involves strategies for *use extension/ intensification, resource (material and energy) consumption reduction, material life extension, toxicity reduction, and resource conservation/ biocompatibility* (ibid). LCD approaches mostly consist of tools with a set of broad, open to interpretation guidelines and checklists. On the other hand, LCA requires a thorough bill of materials (Vogtländer, 2012) which is available at the end of the design process. In the fuzzy front-end of design, the bill of material available is tentative, and an LCA result will be very different when the detailed design is ready. LCA also requires a significant investment in time, effort, and subject expertise (Chiu and Chu, 2012). Conducting the same by large-scale AM manufacturers might be feasible, but SAM manufacturers and designers for small farms of developing countries might not delve into the same. Table 4.4, compiling the LCA based AM research, shows that only 4 out of the 92 cases were for small farm AM from developing countries. Since at the fuzzy front-end of the design process, data availability is low, LCD using a qualitative approach is more

accessible and easier to use. Once the design process is complete, an LCA can be conducted to quantify the environmental impact. Many tools exist for LCA and LCD making the selection process difficult for a specific purpose (Araujo 2001). Table 4.2 below lists some of the LCA and LCD tools available, their scope, weakness, and strengths.

Table 4.2. List of LCA and LCD tools (adapted from (Rossi et al., 2016)).

Tool Category & (Scope)	Weaknesses	Strengths	Examples with reference
LCA (Environmental impact calculation for products/ services.)	Expensive in terms of time, knowledge, economic resources required. Granular data covering life cycle stages is required. A large number of tools are available. Many of these data might not be available in-house and needs to be secured from suppliers. Expertise and experience needed to use the tool as well as to interpret the results.	A full life cycle assessment can be conducted. Products and processes can be compared against each other for environmental impact on various parameters like greenhouse gas emissions, eutrophication. Sensitivity analysis can be conducted to study the robustness of the results and their sensitivity to uncertainty factors.	GaBi ⁴ Simapro ⁵ Quantis ⁶ Sustainable Minds ⁷ Cority Enviance ⁸ OpenLCA ⁹
Simplified LCA (Environmental impact calculation for products/ services without having complete data on the product.)	The knowledge and economic resources required are considerable. A large number of tools are available. Training to use the tools and to interpret data is required. Simplification can result in inaccurate interpretations/ results. Selecting the right tool for the purpose is difficult due to a large number of tools available.	Products and processes can be compared against each other for environmental impact on various parameters like greenhouse gas emissions, eutrophication.	EarthSmart ¹⁰ Corine ¹¹ EcoIt ¹² EIME ¹³ UsesLCA ¹⁴ VSSM, (Kara et al., 2007) EcoScan ¹⁵

⁴ <http://www.gabi-software.com/>

⁵ <http://www.simapro.co.uk>

⁶ <https://quantis-intl.com>

⁷ <http://www.sustainableminds.com>

⁸ <https://www.cority.com>

⁹ <http://www.openlca.org/>

¹⁰ <https://www.earthshiftglobal.com/software/earthsmart-lca-software>

¹¹ <https://www.eea.europa.eu/publications/COR0-landcover>

¹² http://www.adm-global.org/productionsupporttools/Ecodesign_Ecoit.html

¹³ <http://codde.fr/en/our-software/eime-en/eime-presentation>

¹⁴ <http://www.gabi-software.com/support/gabi/gabi-lcia-documentation/usetox/>

¹⁵ <http://ecotoolkit.eu/faq.php>

Tool Category & (Scope)	Weaknesses	Strengths	Examples with reference
Integrated with CAD (Environmental impact calculation for products during design stages and evaluation of impact due to different design choices.)	Knowledge and economic resources are needed. Highly specific. Product modeling needs to be simplified. Training and expenses for purchasing software/ database licenses required. The number of impact indicators is limited, and integration with only a few CAD tools are available.	Product modeling/ design and environmental analysis can go hand in hand.	Marosky methodology (Marosky et al., 2007) Gaha et al. Methodology (Gaha et al., 2011) Rapid LCA (Yang et al., 2012) Demonstrator (Mathieux et al., 2005) EcoFit (Jain, 2009) EcoCAD (Cappelli et al., 2007) CAST Tool (Morbidoni et al., 2011) Solidworks Sustainability ¹⁶ Eco Audit ¹⁷ Ecologic CAD ¹⁸
Diagram Tools (Environmental impact analysis using a mix of qualitative and quantitative methods.)	Results are approximations, and interpretation needs experience. Also, a lot of user-created estimations are used, creating which needs experience. It is a preliminary evaluation tool. The presence of a large number of tools makes a choice difficult.	Requires lower levels of expertise than quantitative methods. Environmentally best options are selected based on qualitative trade-offs between alternatives. The choices are made on the comparison of those life cycle stages, which are different. They are simple and quick and help in visualizing an overview.	Matrix: MECO Matrix (Wenzel et al., 1997) MET Matrix (Brezet and Van Hemel, 1997) ERPA Matrix (Graedel and Allenby, 2010) DFE Matrix (Johnson and Gay, 1995) Environmental Design Strategy Matrix (Allenby, 1994) Spider Diagram: EcoCompass Centre for Sustainable Design (Johnson and Gay, 1995) Ecodesign web (Bhamra and Lofthouse, 2007)
Checklist & Guidelines (Quick qualitative evaluation of impact and suggestion of design cues for improving product environmental performance.)	A lot of user-created estimations are used, creating which needs experience. The checklists and guidelines are generic suggestions and need experience in creating interpretations	Requires lower levels of expertise than quantitative methods. Environmentally best options are selected based on qualitative trade-offs between alternatives. The choices are made on the comparison of those life cycle stages, which are different. They are simple and quick and help in visualizing an overview.	Checklist: Philips Fast Five, Black, white and grey list (Volvo) Behrendt et al. checklist (Behrendt et al., 2012) Guideline: Ten golden rules (Luttropp and Lagerstedt, 2006) EcoDesign Pilot ¹⁹ ELDA (Rose, 2000) Disassembly guide, Design for Disassembly Guidelines (2005) Material selection guide (Allenby, 1994) MATto tool (Allione et al., 2012), Dahlstroml guide (Dahlström, 1999) Lofthouse guide (Lofthouse, 2006) Checklist & guidelines:

¹⁶ <http://www.solidworks.com/sustainability/>

¹⁷ <http://www.grantadesign.com/>

¹⁸ <http://www.solidworks.com/sustainability/>

¹⁹ <http://www.ecodesign.at/pilot/ONLINE/ENGLISH/INDEX.HTM>

Tool Category & (Scope)	Weaknesses	Strengths	Examples with reference
			ICS toolkit ²⁰
Design for X Approach (Targets a particular product environmental characteristic)	These tools focus on single phases or aspects of the life cycle. The designer has to choose the phase of interest and the tool amongst the broad gamut of tools available.	Focused analysis/ design for a particular life cycle stage can be done.	<i>Design for disassembly:</i> (Cerdan et al., 2009 ; Güngör, 2006 ; Huisman et al., 2003 ; Ijomah et al., 2007) <i>Design for remanufacturing:</i> (Gehin et al., 2008 ; Giudice et al., 2005 ; Mathieux et al., 2008 ; Sundin, 2001, 2004 ; Zwolinski et al., 2006) <i>Design for recovery:</i> (Giudice et al., 2001 ; Holloway, 1998 ; Ljungberg, 2007) <i>Design for energy efficiency:</i> (Domingo et al., 2013)
Methods (Includes different types of methods for eco-innovation, life cycle design, and user-centered DfS and the integration of various existing tools.)	Training and experience in using the methods are required. The methods usually consume a considerable amount of time. Skilled staff is needed. The methods are usually complex and elaborate.	The methods follow various approaches and bring in unique strengths depending on the approach selection. Some of them provide the possibility of integrating other existing tools.	(Cappelli et al., 2006 ; Gaziulusoy et al., 2013 ; Germani et al., 2013a ; Germani et al., 2013b ; Gyi et al., 2006 ; Hallstedt et al., 2010 ; Jelsma and Knot, 2002 ; Jones et al., 2001a ; Jones et al., 2001b ; Kobayashi, 2005, 2006 ; Kurzewski and Lewandowska, 2010 ; Le Pochat et al., 2007 ; Lewandowska and Kurzewski, 2010 ; MacDonald, 2005 ; Pigosso et al., 2013 ; Rodriguez and Boks, 2005 ; Russo et al., 2011 ; Tingström and Karlsson, 2006 ; Wever et al., 2008 ; Yang and Chen, 2011)

To analyze the nature of research in the context of LCA applied to AM, literature research was conducted using the keywords *LCA AND agricul** AND *machin** (limited to exact keywords “Agricultural Machinery” or “Machinery” and “Life Cycle Assessment (LCA)” or “Life Cycle Assessment” or “Life Cycle Analysis” and English language) on Scopus. The search resulted in 92 relevant results. [Table 4.3](#) and [Table 4.4](#) below present the results' summary, and [Appendix 2](#) presents the detailed results. Literature reveals 78 (out of 92) papers deal with AM selection case studies where one could choose between alternate machinery/ mechanization solutions using an LCA approach (Example - ([Aguilera et al., 2019](#); [Bacenetti et al., 2016b](#); [Lovarelli et al., 2018a](#); [Proto et al., 2017](#))). Some of these studies suggest integrating the LCA approach with considerations to specific economic (6 out of 92), or social and economic aspects (3 out of 92). For example, a study by ([Bernardi et al., 2018](#)) assesses the sustainability of mechanization of various olive-harvesting scenarios by comparing them based on LCA, work productivity, and harvesting cost. Only one paper ([Glatt et al., 2019](#)) dealt with LCA applied to an AM-based PSS.

LCA has also been used to compare agricultural value chains' mechanization by comparing different transportation, fuel usage, and other input scenarios. These studies help identify stages in the value chain with the highest impact and that of different sourcing and distribution decisions (Example - ([Ewemoje and Oluwaniyi, 2016](#); [Kollmann et al., 2016](#))). LCA aids in identifying the stages of a product's life cycle with the highest impact and designing interventions to counter the same. It is supported by LCA tools ([Table 4.2](#)) and databases, which quantifies the environmental impact. Thus,

²⁰ http://www.lens-international.org/tools/view/5?server_id=3

competing product and process solutions can be compared against each other in terms of environmental impact, and appropriate design choices can be made. However, as highlighted by [Park and Tahara \(2008\)](#), LCA tools are useful for comparing alternate product solutions and scenarios but not for identifying critical environmental problems in products and making strategic decisions accordingly.

36 out of the 92 papers studied LCA of AM only on the consumption side by measuring energy consumption and emissions, while 43 studied both the production and consumption side. Five of the papers improved the LCA on the consumption side using sensors, predictive usage models, and artificial intelligence. AM design with an LCA approach helps identify the environmental impact on the production side as it is a one-time event ([Reap et al., 2008](#)). The focus and control over the production-side help achieve “doing more with less” through technology improvisation and building technical systems that consume fewer or renewable resources and waste minimization. This has also substantially reduced the cost of production and ownership in many cases. The assessment on the consumption phase, which might account for 60-80% of the impact, and that on the end-of-life treatment is studied mostly as probable scenarios. In real-life, these scenarios might be very deviant, and environmental performance cannot be guaranteed as per calculations. For example, researchers report that farmers tend to purchase and use higher power tractors and pumps than they need, leading to economic losses ([Singh, 2010](#)). The losses are higher for small farm holders than the larger ones (ibid). [Michaelis \(2000\)](#) reports that whenever production processes have moved towards more eco-efficient processes leading to a reduction in the cost of ownership or running a product, the consumption has increased, leading to higher production and stress on the environment. Thus, it eventually leads to unsustainable consumption. Another problem with the consumption-side measurements is, unlike the production-side, it is time-dependent. The temporal factors relevant for AM’s LCA in the consumption phase can be “*different rates of emissions over time and seasonal variation of their impact*” ([Reap et al., 2008](#)). Additionally, spatial variations can also have an impact (ibid). ([Ma and Kim, 2015](#)) proposed a model for usage pattern mining of AM using sensors that can identify seasonality, manage missing and abnormal values from large-scale sensor data, and build a predictive LCA equation for current and new AM. Other researchers are integrating artificial intelligence approaches (machine learning, neural networks) with LCA to improve the data gathering process and prediction of impact ([Barros and Ruschel, 2021](#)). However, LCA still is not geared to capture the human dimension characterized by aspects like needs, demands, values, aspirations, attitudes, and behavior, which are important determinants of consumption behavior.

Table 4.3. Categorizing the literature based on the aim of the study.

Aim	No. of papers
LCA comparing scenarios (product design/ processes/ stages/ geography/ time/ size of operation)	78
LCA combined with socio-economic efficiency	3
LCA combined with economic analysis	6
LCA applied to PSS	1
LCA on the AM consumption side only	36
LCA on the AM production and consumption side	43
Usage modeling for LCA/ artificial intelligence-based LCA for the consumption side	5
LCA dataset analysis/ generation	8
Total Papers	92

Table 4.4. Categorizing the literature based on geography under investigation and farm size.

Country	No. of papers	Studies for small farms*
Global	1	0

European Union	1	0
Argentina	1	0
Australia	3	0
Bangladesh	1	0
Belgium	2	0
Brazil	9	0
Chile	1	0
China	2	0
Colombia	1	0
Denmark	1	0
France	2	0
Germany	2	0
Ghana	1	1
Greece	1	0
India	1	0
Iran	5	1
Italy	29	1
Mexico	1	0
Nigeria	1	0
Peru	1	1
Poland	1	0
Portugal	2	0
Republic of Serbia	1	0
South Africa	1	0
South Korea	1	0
Spain	9	0
Sweden	2	0
Switzerland	1	0
US	9	0
Total Papers#	92	4

* Includes those where it is mentioned that the study considered small farms.

Some papers consider two countries.

Thus, despite several strengths of LCA in measuring, comparing, and operationalizing environment-friendly design, it is alone, not sufficient as an approach to AM design for achieving sustainability holistically, i.e., on all three dimensions and both the consumption and production side. LCA is also less efficient (information availability, time, resources required) in the design process's fuzzy front-end. LCA results can vary widely based on functional unit choice or the database used for the calculations. Thus, 8 out of the 92 papers identified dealt with analyzing existing databases and generating contextually appropriate new datasets. Out of the 92 papers, only four papers dealt with the context of AM for small farms of developing countries. Twenty-eight papers were from developing countries. This might be attributed to the fact that LCA is a quantitative tool requiring substantial expertise, data, time, effort, and financial resources.

Using a checklist and guidelines, unlike the quantitative LCA, the LCD approach is more suited at the fuzzy front-end of design since it is a qualitative tool. An efficient LCD tool, suited to designers, should have an approach of providing the designer with "guidance, education and information" (Lofthouse, 2006). AM design needs substantial attention to product design. Though exclusive dependence on lifecycle-based design methods is insufficient, designing without it can give less stress on AM's (as a product) impact on the environmental dimension. To analyze the nature of research in the context of LCD applied to AM, literature research with keywords *life cycle design* AND *agricul** AND

*machin** (limited to exact keywords “Agricultural Machinery” or “Machinery” and “Life Cycle Assessment (LCA)” or “Life Cycle Assessment” or “Life Cycle Analysis” and English language) on Scopus resulted in 51 results. Further investigation of these papers resulted in 5 relevant results of which one was common with the previous search. (Glatt et al., 2019) (common paper) presents a cumulative energy demand-based method to analyze an AM-based PSS. It excludes all other life cycle impacts and is a quantitative assessment tool. Wang et al. (2018) propose the use of TRIZ to map the “relationship between ecological efficiency factors and 39 engineering parameters,” and thereby, the ecological efficiency issues of an AM are seen as engineering problems. The mapping can provide an opportunity to ideate on new products. Chakroun et al. (2010), on the other hand, uses a combination approach involving LCA and TRIZ. The first step involves conducting an LCA to identify the environmental impact. Next environment-related problems are identified using field tests and customer research. After that, in the third step, environmental impacts are associated with problems by the designer. In the fourth step, the designer formalizes the critical problem using four other tools: *Innovation Situation Questionnaire*, *Root Cause Analysis*, *Ideal Final Result*, and *Pattern of Evolution*. The final stage is the ideation stage using the eight main patterns of evolution in TRIZ. Although TRIZ offers an innovation-oriented approach to LCD, it is not a comprehensive tool that can combine the activities of analysis (existing), design (new), and evaluation (compare existing vs. new) for environment-friendly design. Dunmade and Rosentrater (2006) suggest using DfX (X for modularity, cost, assembly, manufacturability, disassembly, maintainability, reusability, and re-manufacturability) along with socio-economic considerations for LCD of AM. Despite the strengths of the approach, no unified tool is presented, which designers can use to analyze, design, and evaluate various life cycle phases for environmental impact.

Thus, in the absence of any dedicated LCD tools for AM, we investigated the efficacy of LCD tools from the domain of product design. In this thesis, we evaluate the efficacy of an LCD approach while designing the AM using the ICS toolkit (Vezzoli and Manzini, 2008). The toolkit consists of engineering criteria and guidelines for the analysis, priority setting, design, and environmentally sustainable product evaluation. It uses the basics of the LCD approach: *use extension/ intensification*, *resource (material and energy) consumption reduction*, *material life extension*, *toxicity reduction*, and *resource conservation/ biocompatibility* (ibid). The toolkit investigates the entire life cycle of a product. It gives the possibility of setting varying degrees of priority to different aspects of environment-friendly LCD. It aids in identifying environmental concerns in existing products (Figure 4.2), setting strategic product design priorities (Figure 4.2), provides design cues to ideate (Figure 4.3), and a possibility to conduct a qualitative comparison between alternatives (Figure 4.4 and Figure 4.5).

The rationale for selecting the ICS toolkit over a large number of other tools available (Table 4.2) is:

- ♦ It is a checklist and guidelines-based tool. Consequently, it is very suitable for use at the fuzzy front-end of design where data availability is sparse. Also, the training requirement for using such tools is significantly less. The time requirement is relatively lesser than other tools. The tool design's very nature can be used for data gathering and participatory design with both experts and non-expert stakeholders.

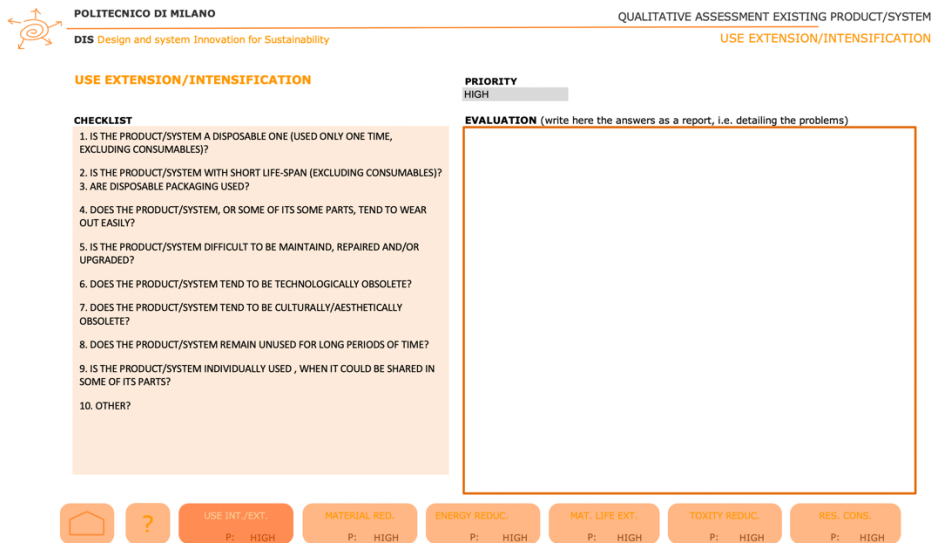

Figure 4.2. ICS toolkit screenshot showcasing a sample screen demonstrating how to evaluate and identify environmental concerns in existing products.



Figure 4.3. ICS toolkit screenshot showcasing design cues for ideation on the parameter *use extension/ intensification*.

- ◆ The checklist section of the tool helps identify problems, and the guidelines section guides on possible ways to solve them. This is in line with [Lofthouse \(2006\)](#) research amongst industrial designers, which shows that designers want an ecodesign tool, which is a combination of “guidance, information, and education.”
- ◆ The tool offers three granular levels of evaluation: *simplified*, *normal*, and *deep*. The designer depending on time, information, and personal expertise level, can select one evaluation method.
- ◆ The tool offers three layers of focus in one tool: a retrospective analysis of existing products, design of new products, and strategic product management—a feat which is not so common amongst other tools ([Walker, 1998](#)).
- ◆ It caters to all stages of the life cycle for a product.
- ◆ The tool is freely available and is built on Microsoft excel. This ensures the availability of the same for a wide variety of audiences. All the information is divided up into nuggets of information, making it easier and quicker to grasp. The tool provides ample opportunity for interpretation and hence creative exploration for the designer. This is evident from an example of a design guideline

statement - “plan and simplify the replacement of hardware parts to favor upgrading” or an evaluation question – “is the product/ system, or some of its parts tend to wear out easily?”

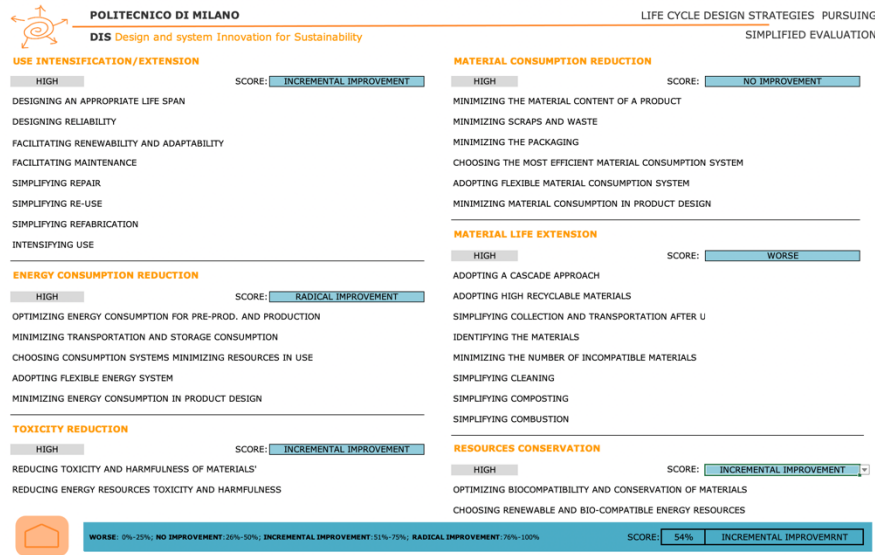

Figure 4.4. ICS toolkit screenshot showcasing “simplified evaluation” of new concept vs. existing product.

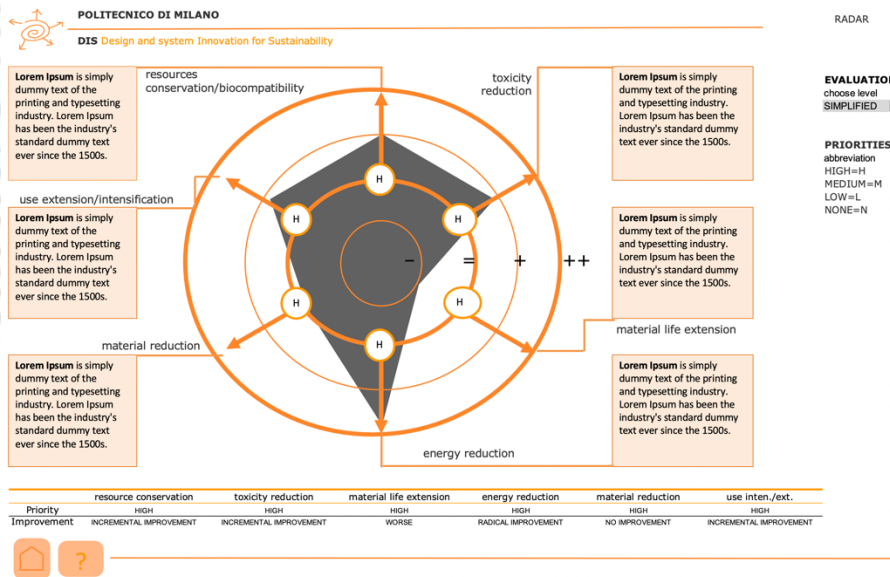

Figure 4.5. ICS toolkit screenshot showcasing a visual representation of “simplified evaluation” of new concept vs. existing product using a radar diagram.

4.3. PSS innovation - Satisfaction-based approach for SAM

PSS design is a design approach where a product and its associated services are designed together as a system offering to satisfy customers’ needs. Changing markets and recognizing that when services are bundled with products as an offering, profit margins are higher, is leading to PSS's push in the otherwise traditional manufacturing-oriented companies (Sawhney et al., 2003). Thus, Goedkoop et al. (1999) defined a PSS as a “marketable set of products and services capability of jointly fulfilling a user’s needs.” According to Boehm and Thomas (2013), theoretical developments for PSS design can be traced to different fields: Information Systems, Business Management, and Engineering & Design. The authors reviewed 265 papers, 115 of which dealt with the conceptualization of design supports for PSS, while only 23 dealt with the concept of sustainability. Velamuri et al. (2011) classified the research viewpoints

in PSS's domain into eight categories: Strategic view, organization view, marketing view, design view, innovation view, business-level view, sustainability aspects, and macroeconomic perspective. Of these viewpoints, the design, sustainability, and macroeconomic viewpoints have the most contributions to sustainability. According to [Ceschin, F. \(2013\)](#), PSS business models can be distinguished into two categories: conceptualized to be eco-efficient and sustainable while the others are not. Researchers have also shown case studies where PSS can harm the environment while maintaining its profitability ([Kuo, 2010](#); [Tukker, 2004](#)). Hence a PSS needs to be consciously designed, keeping in mind sustainability concerns and strategize to avoid rebound effects ([Tukker, 2004](#); [Tukker, Arnold and Tischner, Ursula, 2006](#); [Vezzoli et al., 2014](#)).

Literature research on design supports for S.PSS is conducted using the keywords *sustainable* AND *“product service system”* in Scopus amongst research published in English. These papers (261 in number) were further investigated to identify 86 relevant results (the year 2000²¹-2015). From ([Maxwell et al., 2006](#)), seven more relevant papers were identified. Concepts like “functional economy” or “dematerialization” are used in many PSS papers and are semantically connected to the concept of sustainability ([Lee, S. et al., 2012](#)). However, in our research, we have selected only those design supports, which are consciously designed, keeping in mind sustainability concerns. The papers present design supports, broadly categorized as design supports for S.PSS design, evaluation, modeling and simulation, and operation. [Appendix 3](#) presents the list of these design supports, categorized as design supports for S.PSS design, evaluation, modeling and simulation, and operation along with information on the target sector for which they have been built. The category S.PSS design includes all those papers that present design supports for either only S.PSS design or ideation or innovative thinking for S.PSS design or involve supports for a combination of stages: analysis, design (must-have), and evaluation. The analysis of the available design supports for S.PSS reveals 25 supports for S.PSS design, 6 for S.PSS business model design, 4 for service design for S.PSS, 10 for modeling and simulation, 19 for evaluation, and 18 for operation ([Figure 4.6](#)). 36 out of the 93 supports are designed as generic supports which can be used for any S.PSS while 2 of them are for design of AM ([Figure 4.7](#)). These are paper Id 2 and 10 from [Table 4.5](#) and are further discussed in section 4.5. Of the 25 S.PSS design supports, two supports ([Joore and Brezet, 2015](#); [Vezzoli et al., 2014](#)) were examined in greater detail since they presented a holistic structure comprising a design framework and tools and tackled all life cycle stages. ([Joore and Brezet, 2015](#)) was not taken forward since it catered to a broader picture of addressing “societal change” through S.PSS. This was not required for the design of SAM.

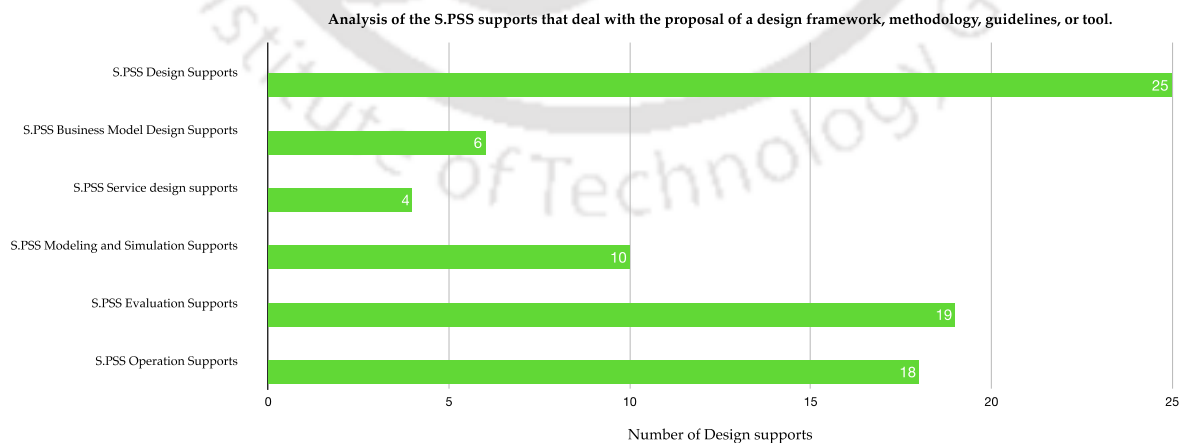

Figure 4.6. Analysis of the nature of S.PSS supports that deals with the proposal of a design framework, methodology, guidelines, or tool.

²¹ starting year for such papers in Scopus database was 2000.

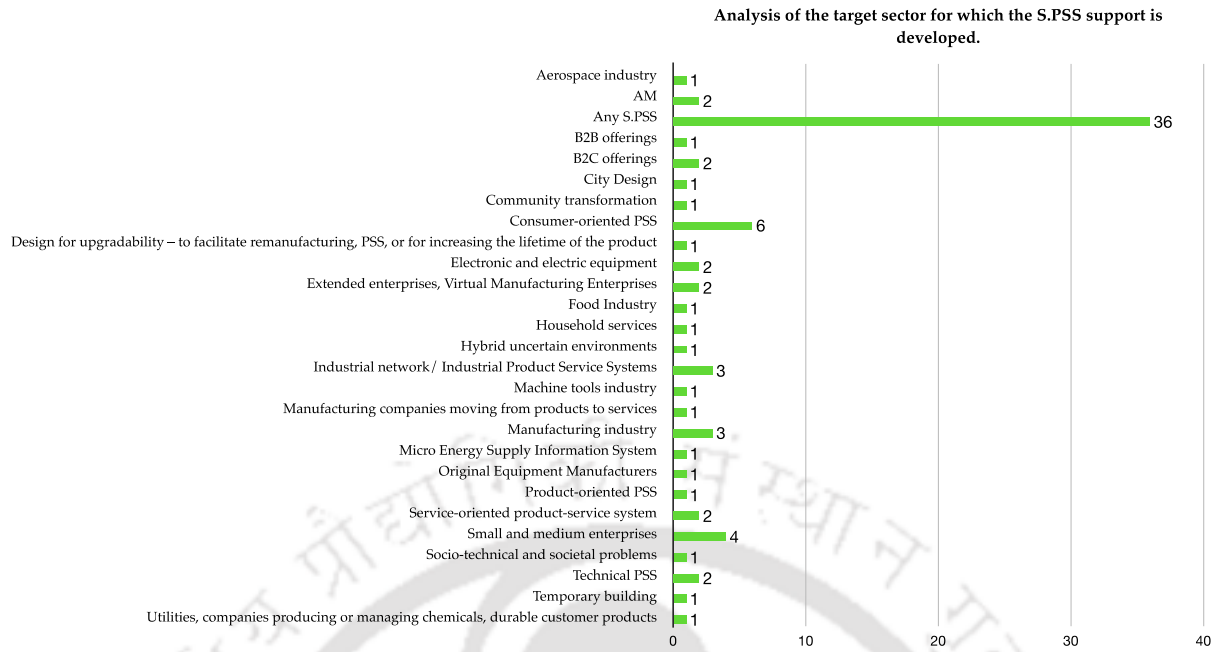

Figure 4.7. Analysis of the target sector for which the S.PSS support is developed.

The MSDS by (Vezzoli et al., 2014) was selected as the design for the S.PSS approach for designing SAM because:

- The methodology is designed for the context of a satisfaction-based approach. It uses the S.PSS definition as “an offer model providing an integrated mix of product & services that are together able to fulfill a particular customer demand (to deliver a ‘unit of satisfaction’) based on innovative interactions between the stakeholders of the value production system (satisfaction system), where the economic and competitive interest of the providers continuously seeks both environmentally and socio-ethically beneficial new solutions.” (Vezzoli et al., 2014). This resonates with the context of SAM for small farms of developing countries. SAM is comprised of the AM and its ecosystem that may include services like manufacturing, maintenance, spare parts, training, machine operation services, and financial services. Thus, the design for the S.PSS structure focusing on the design of the entire business ecosystem rather than standalone products or single aspects is well-suited.
- MSDS provides a holistic and systems-oriented view of sustainability. It concurrently caters to the three dimensions of sustainability. Additionally, the methodology provides the flexibility to accord contextually appropriate priorities to each of them. Considering the broad spectrum of SAM requirements and operation contexts, this flexibility is a plus.
- It integrates methods, tools, and learnings from other projects whose tools are mentioned in Appendix 3. These projects were funded by the UNEP (Tischner and Vezzoli, 2009a) and the European Union (SusHouse: Strategies towards the Sustainable Household (Vergragt and Green, 2007), ProSecCo: Product-Service Co-design (Auernhammer and Stabe, 2002), HiCS: Highly Customized Solutions (Manzini et al., 2004), MEPSS: Methodology for Product Service System development (Van Halen et al., 2005), and SusProNet: Sustainable Product-Service co-design Network (Tukker, A. and Tischner, U., 2006). It has also been tested to develop sustainable system concepts (Ceschin and Vezzoli, 2007; S. Cortesi et al., 2010; Vezzoli and Ceschin, 2009). Thus, MSDS is a robust methodology.
- It provides a design approach or methodology, i.e., “an overall framework for doing design” along with design tools, i.e., “hardware and software for supporting design, based on some design approach, method or set of guideline.” The methodology supports analysis of the existing system and thereby sets DfS priorities, ideating on sustainability-oriented opportunities, detailing and engineering

alternative systems, and finally, a qualitative evaluation of the redesigned system's sustainability potential. Thus, it consists of four main procedural stages: 1) Strategic analysis; 2) Exploring opportunities; 3) Designing system concepts; 4) Designing and engineering a system. The designer has the flexibility to use all or some of the stages as per the project scenario. Each stage comes with a set of tools. The designer can use any of the tools as per requirement and add other tools not designed explicitly for MSDS. A strong focus on participatory design is laid in MSDS. Designing SAM needs the integrated efforts of various expert stakeholders and grassroots stakeholders using a participatory design approach.

- ◆ It presents the opportunity to analyze existing “cases of excellence for sustainability” and evaluate the redesigned system against these cases for sustainability improvement.
- ◆ The SDO toolkit in MSDS helps to examine the environmental, social, and economic sustainability of the current scenario qualitatively, set intervention priorities, aid in system and service level ideation, and evaluate sustainability improvements qualitatively. The toolkit's qualitative nature is very apt at the fuzzy front-end of the design process, where data availability is low and incomplete. Also, the scenario of designing of SAM for small farms of developing countries is a low resource (skilled human resources, data, time) design context. Thus, the qualitative toolkit is very apt.

4.4. The rationale for selecting S.PSS as the design for sustainability approach

Literature reveals several AM design case studies that follow an LCA approach ([Table 4.3](#)). However, LCA does not offer much control over the consumption side, mostly determined by human consumption behavior. As a result, despite the signs of progress made by the industries and the industrialized countries worldwide in developing and adopting sustainable production processes, global consumption exceeds the Earth's capacity to supply resources and absorb the wastes and emissions produced. Thus, both consumption and production need to be investigated to achieve sustainable development ([Park and Tahara, 2008](#)). [Throne-Holst et al. \(2007\)](#) suggest a PSS approach, a ‘satisfaction-based approach’ to handle the sustainability challenges resulting from our consumption and production practices. A PSS approach's sustainability potential arises when the system is designed and incentivized to promote sustainable consumption choices ([Tukker, A. and Tischner, U., 2006](#)). PSS approach tries to design offer models where being sustainable is in the producer's economic interest, and hence, economic value creation is not dependent on increased resource consumption ([Baines et al., 2007](#)). Thus, the sustainability potential of S.PSS based DfS approach is higher than that of LCA or LCD based approach.

SAM is comprised of the AM and its ecosystem that may include services like manufacturing, maintenance, spare parts, training, machine operation services, and financial services. Thus, the S.PSS structure design, focusing on the entire business ecosystem's design rather than standalone products or single aspects, is well-suited to achieve sustainability. However, as SAM's product component, the AM, is an important contributor to environmental (un)sustainability, LCA should be an integral part of the assessment and design process. The spatio-social and the socio-technical levels ([Ceschin and Gaziulusoy, 2016](#)) of innovation are not suitable for the context of SAM. Hence, we propose to test the efficacy of MSDS (an S.PSS methodology) and ICS toolkit (an LCD toolkit) for SAM's design.

4.5. Sustainability-orienting design approaches from agricultural practices

A literature review was conducted in the agriculture domain to identify relevant research and development in sustainability-orienting design supports. A search using the search engine, Scopus, keyword search, *sustain** AND *agricul** AND *machin**, revealed 912 results in articles, conference papers, book chapters, and books in English. This was further refined by selecting the keywords, *Agricultural Machinery*, and *Machinery* giving 471 results. The paper title and abstract of these papers were read

through for relevant topic identification. 11 papers were found relevant, and the whole papers were studied to identify 4 papers relevant to the area of interest. Another keyword search *sustain** AND *agricul** AND *mechanization* revealed 196 documents in English in articles, conference papers, book chapters, and books. The paper title and abstract of these papers were read through for relevant topic identification followed by the entire paper's study. 2 common papers and 4 new papers were found. Next, a literature search was conducted using the search engine, Web of Science, with keyword search, *sustain** AND *agricul** AND *machin**. 251 results were obtained in English in articles, conference papers, book chapters, and books. The title and abstract were read through for identifying the relevant papers. 1 new paper was found. Next, the keyword searched was changed to *sustain** AND *agricul** AND *mechanization*, which revealed 88 results whose title and abstract were read through for identifying the relevant papers. 2 common papers were found. Papers on only LCA based design or analysis of the machinery or mechanization were excluded since they cater only to the environmental dimension. Another keyword search on Scopus and Web of Science for *PSS* AND *agricul** AND *sustain** revealed 7 and 3 papers, respectively, of which only 1 paper from Scopus was relevant. [Table 4.5](#) lists the search results along with the key concepts covered in the papers.

The literature review reveals that although there are a wide variety of sustainability assessment methods in the domain of agriculture ([Abdollahi et al., 2015](#); [Binder et al., 2010](#); [Marchand et al., 2014](#); [Schader et al., 2014](#)) (listed in [Appendix 5](#) and discussed in section [6.2.1](#)), catering to all three dimensions, none of them are specifically designed for AM. Also, these tools from the agriculture domain are designed for assessment and do not provide design support. All the ten identified papers stress the need to involve multiple stakeholders and disciplines in the DfS process for SAM. However, none of them present holistic sustainability-orienting design support. Paper Id 1 ([Bezruk et al., 2014](#)) stresses that AM, as durable goods, has a significant impact on agricultural operations' sustainable production processes. Hence, sustainable AM or mechanization can be considered as a vital tool in sustainable agriculture. The authors present a survey conducted in Germany amongst farmers to understand their attitude towards sustainability in the AM manufacturing process and how they value and perceive AM manufacturer's commitment to sustainability. Paper Id 2 ([Corti et al., 2015](#)) explores avenues for developing guidelines for designing business models with a service and sustainability orientation for the AM sector. It has a multi-stakeholder approach towards developing business models and has interviewed a broad spectrum of manufacturers and service providers for achieving the same. Nevertheless, no elaboration on the sustainability matrix for the development of the service and sustainability-oriented business model, as mentioned in the aim, has been presented. Paper Id 3 ([Jongebreur and Speelman, 1997](#)) discusses the importance of agricultural engineering, design of farm machinery, equipment and management as multidisciplinary fields of science and chalks out "*technical (system- and process quality control) and socio-economic parameters (investment costs, price/ quality ratio, employment)*" based future pathway for sustainable development in the area. Paper Id 4 ([Gathorne-Hardy, 2016](#)) discusses that a large part of the study on agricultural technology and its transition impacts are confined to individual knowledge disciplines. For example, the economic consequences of farm energy choices have been studied at the macro-economic level, while the impact of energy and greenhouse gases has been studied at the farm scale. According to the author, multi-disciplinary research is required to fully understand the social, economic, and physical impact of agricultural technology transitions. However, there is a dearth of such studies. Hence the author uses an LCA method to determine the greenhouse gas emissions and also maps the costs and labor requirements to compare a tractor-based operation versus a bullock-based field operation. This is the only research paper amongst the ten where the study context is small farms of a developing country. Paper Id 5 ([Vieri and Sarri, 2010](#)) presents an assessment of AM for the olive industry based on "*agricultural efficacy, technological and operational efficiency, and internal and external, direct and indirect obligations with economic sustainability and the effective possibility of performing the necessary operations on the entire area to be managed.*" Paper Id 6 ([Veisi, 2012](#)) presents a mathematical decision-making model for the selection of an Integrated Pest Management system using four factors: 1) Exogenous factors (policies and planning

at the national and local level, information and input access, and reference groups' attitude); 2) Farm characteristics (size, soil quality, mechanization, plot distribution, and labor use); 3) Farmer characteristics (age, education, experience and knowledge, attitude, on-farm income, off-farm income, quality of life, and spiritual and religious beliefs); and, 4) Characteristics of innovations (practicability of Integrated Pest Management practices. Paper Id 7 ([Romanelli and Milan, 2012](#)) also presents a decision-making model, a combination of LCA and socio-economic parameters. To conduct the analysis, first, the system is represented diagrammatically, and next, the material flows for directly and indirectly (field capacity, fuel consumption, machinery depreciation, and labor) applied inputs are determined. After that, the efficiency of AM usage due to the farm's size characteristics is determined. Paper Id 8 ([Brinks and Kool, 2006](#)) suggests a network-based approach, with varied farm stakeholders. The authors argue that the approach shows to be successful when common interests can be identified. Paper Id 9 ([Hendrickson et al., 2008](#)) suggests the concept of "dynamic-integrated agricultural systems" to achieve sustainability because of its ability to consider multiple goals and flexible producer decision-making. The author suggests the need for interaction between social, political, economic, environmental, and technological drivers. Paper Id 10 ([Ziout and Azab, 2015](#)) presents PSS metrics for the agricultural industry and uses a PESTEL analysis to determine these metrics.

Table 4.5. Literature review: key concepts from existing sustainability-oriented analysis and design guidelines for AM. (from published paper ([Banerjee and Punekar, 2020](#)))

Paper Id	Reference									
1	(Bezruk et al., 2014)									
2	(Corti et al., 2015)									
3	(Jongebreur and Speelman, 1997)									
4	(Gathorne-Hardy, 2016)									
5	(Vieri and Sarri, 2010)									
6	(Veisi, 2012)									
7	(Romanelli and Milan, 2012)									
8	(Brinks and Kool, 2006)									
9	(Hendrickson et al., 2008)									
10	(Ziout and Azab, 2015)									
Key Concepts	Paper Id									
	1	2	3	4	5	6	7	8	9	10
Sustainability concerns need to be deliberated while designing AM	√	√	√	√	√	√	√		√	
¹ Sustainable on social, economic & environmental dimension	√		√	√	√	√			√	√
Accessing stakeholders' perspectives to define sustainability for a given context	√				√	√				
Sustainable PSS oriented approach		√								√
Network-based approach								√		
Suggests the involvement of multiple stakeholders		√			√	√		√		√
Suggests the involvement of multiple disciplines			√	√	√					
System Design approach	√	√	√	√	√	√	√	√	√	
Presents primary data and interdisciplinary research				√	√	√	√			
Research conducted in a developing country				√						
Uses quantitative analysis							√			
Uses qualitative analysis									√	

¹ When an explicit mention of all three dimensions is present, √ has been placed against it.

FAO's website on SAM ([FAO, 2016b](#)) describes SAM as: "Sustainable agricultural mechanization covers all levels of farming and processing technologies, from simple and basic hand tools to more sophisticated and motorized equipment. It eases and reduces hard labor, relieves labor shortages, improves productivity and timeliness of agricultural operations, improves the efficient use of resources, enhances market access, and contributes to mitigating climate-related hazards. Sustainable mechanization considers technological, economic,

social, environmental, and cultural aspects when contributing to the sustainable development of the food and agricultural sector." The website, thus, provides a broad description of what SAM should be. However, no design support is available.

4.6. Conclusion

From the discussions presented so forth, it is evident that there is no sustainability-orienting design support from the domain of agriculture which addresses sustainability concerns for the design of SAM for small farms of developing countries

- ♦ Considering the social, economic, and environmental dimension concurrently; and,
- ♦ Throughout the life cycle, i.e., from design, development, manufacturing, sale, use, repair, and maintenance to end-of-life.

LCA-based approaches for comparative evaluation of competing machinery or mechanization scheme designs exist, but they can only check for the environmental dimension. The S.PSS methodology, MSDS, and the ICS toolkit, which are sustainability-orienting design supports from product design domain, can be further analyzed by applying it to SAM design context to check for efficacy and sufficiency.



5. Case Study: Sustainability-oriented design of a bed planter

In this chapter, we apply the S.PSS methodology, MSDS, and the ICS toolkit, which are sustainability-oriented design supports from the product design domain, on a SAM design context to check for their efficacy and sufficiency. Thus, in this chapter, we answer research question 1, which enquires:

Do current sustainability-oriented design supports address sustainability concerns for the design of SAM for small farms of developing countries

- ◆ Considering the social, economic, and environmental dimension concurrently; and,
- ◆ Throughout the life cycle, i.e., from design, development, manufacturing, sale, use, repair, and maintenance to end-of-life?

Testing MSDS and ICS toolkit on the case study also helped to answer the research question 2 (part 1), which enquires:

What could be a possible sustainability-oriented design support for the design of SAM for small farms of developing countries that take into account:

- ◆ The pros and cons of the existing sustainability-oriented design supports from related domains (part 1); and
- ◆ Addresses a holistic picture of sustainability, including its three dimensions (social, economic, and environmental), in the given context?

The case study was presented as a participatory design research case in ([Banerjee, 2015](#)), and the development of the sustainability-oriented design methodology for SAM design is published in ([Banerjee and Punekar, 2020](#)).

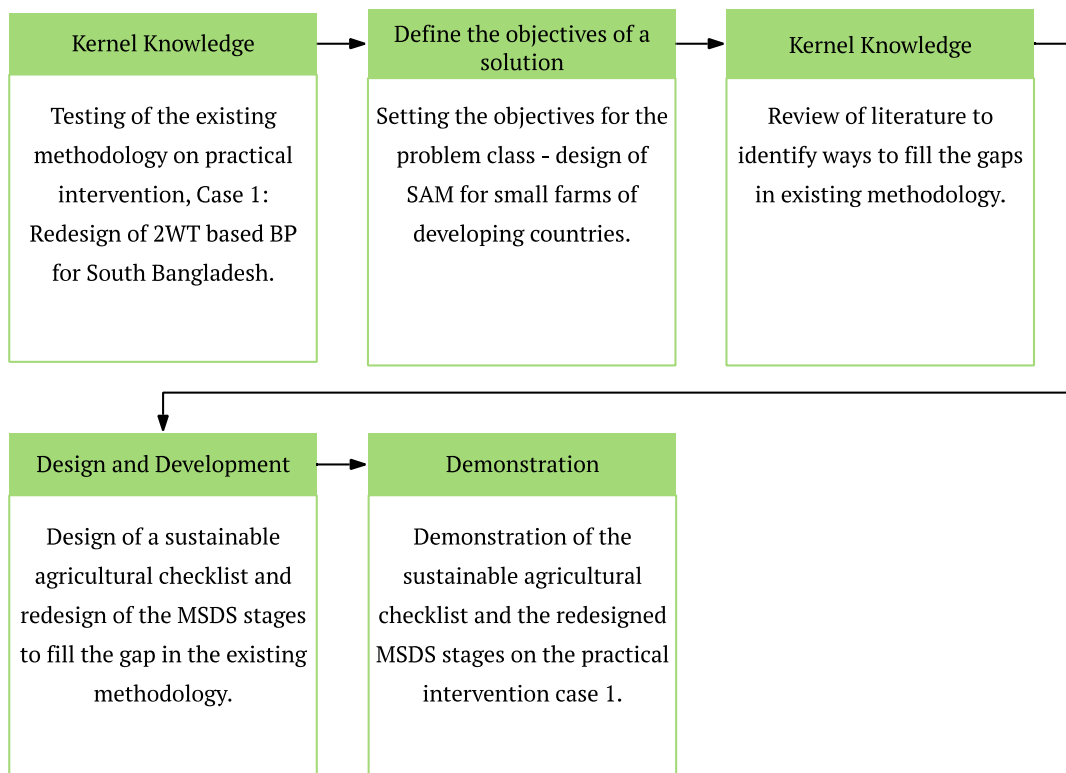

5.1. About the case study

The journey begins with a case study of scale-appropriate AM redesign exercise in Bangladesh's small farm context. The project aimed at the redesign of a 2WT based BP ([Figure 5.1](#)). The project was part of the scheme Cereal Systems Initiative for South Asia - Mechanization and Irrigation (CSISA-MI). CSISA-MI is jointly run by International Maize and Wheat Improvement Center (CIMMYT) Bangladesh²² and International Development Enterprise Bangladesh (iDE-B)²³. USAID Mission in Bangladesh under President Obama's Feed the Future Initiative funded the project. We used the BP designed by the Bangladesh Agricultural Research Institute (BARI) and reverse-engineered by a local workshop owner, Oli Hujjur of Janata Engineering (JE), as the commencement point.



Figure 5.1. A BARI designed BP, reverse-engineered by Mr. Oli Hujjur of JE.



Figure 5.2. Beds and furrows built by the redesigned BP.

Bed planting is a crop establishment method in which furrows and elevated beds alternate ([Figure 5.2](#)). Farmers plant the seeds on the bed and irrigate the furrows. The furrows provide access to the fields. Farmers in heavy rainfall and flood-prone areas of Bangladesh and many other countries use bed planting to protect their crops from water to a certain extent. The said design's target consumers were farmers with less than a third of an acre of land. The focal area was South of Bangladesh in Khulna and Jessore districts. Due to the small size of the landholdings, these farmers also belonged to the low-income group. In the given region of Bangladesh, 2WT based implements were very popular and operated using a service model. A LSP would own the 2WT and its implements, employ an operator or work himself as one, and provide farmers with on-demand services. The farmers hiring the service would pay for the service on an hourly basis, depending on the service type, like soil preparation, puddling. The principal crops for which the BP was targeted were wheat, maize, green gram, mustard, and sesame.

According to [Esdaile et al. \(2009\)](#), Bangladesh's farmers have adopted scale-appropriate AM to a reasonable extent. Also, the farm labor shortage has caused good penetration of mechanization in the country. There are many types of farm implements based on 2WT. The cost and the scale of operation, as afforded by 2WT, are considered suitable for small and medium farms ([NABARD; Narang and Tiwari, 2004; Pandey and Gaur, 2007; Tiwari and Varshney, 1997](#)). The two brands of 2WT most popular in the region were Dongfang and Sifang, both Chinese manufacturers. The 2WT were available in mostly 9 HP, 12 HP, and 13 HP variants. BARI has done pioneering work in the country in the field of 2WT based AM development. [Hossain et al. \(2010\)](#) had developed a Dongfang make 2WT based BP, henceforth referred to as D-BP. BP is a machine that first plows the field, then applies seed and fertilizer

²² CIMMYT is a non-profit organization and focusses on research and training to improve the yield of wheat and maize

²³ iDE-B is an NGO focusing on income and livelihood generation for Bangladesh's rural poor.

in furrows, and finally creates the bed. [Figure 5.3](#) shows the sub-assemblies of a BP and explains the function of each. The details of the sub-assemblies are presented in section [A4.1.2](#).

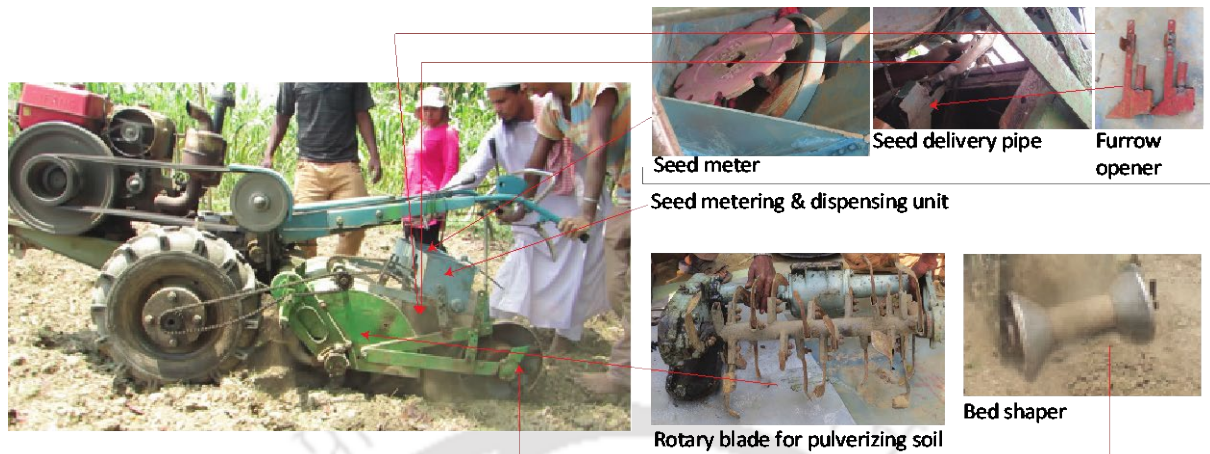

Figure 5.3. BP parts and their functions.

iDE-B and CIMMYT are actively working in mechanization and irrigation in South Bangladesh under the project CSISA-MI. In this part of the country, Sifang make of 2WT is the most common. A very ingenious local workshop owner, Mr. Oli Hujjur, reverse-engineered the D-BP and converted it into a BP for the Sifang make 2WT, henceforth referred to as S-BP. 50 S-BP were made and put up for sale through distributors by iDE-B and CIMMYT. Nevertheless, sales did not materialize.

The interesting point to be noted here is that bed planting as an agronomic process is widespread in Bangladesh. Farmers were bed planting manually as no machinery was available in the market. Hence, it was anticipated that it would sell reasonably well when a machine is introduced in the market. Further, iDE-B and CIMMYT have considerable experience in commercializing various AM in the country and have been quite successful in their endeavors. After failing to sell the S-BP, iDE-B commissioned me to redesign it.

5.2. Assessment of the efficacy and sufficiency of MSDS methodology and ICS toolkit on a SAM case

We tested the four main stages of MSDS (*strategic analysis, exploring opportunities, designing system concepts, and designing and engineering system details*) and the ICS toolkit on the case. The following sub-sections present the data collection methodology, results, and discussions. The detailed case study is presented in [Appendix 4](#).

5.2.1. Data collection methodology

We collected the data from expert and grassroots stakeholders ([Figure 5.4](#)). The JE owner, scientists, engineers, and staff of CIMMYT and iDE-B are referred to as experts. Except for the JE owner, all others are formally educated and trained. JE owner is classified as an expert stakeholder as he self-trained himself with AM and its manufacturing processes due to his keen interest and acumen for it. The farmers, LSPs, operators, and manufacturer's staff are classified as grassroots stakeholders as they are trained on the job and are mostly illiterate or semi-literate.

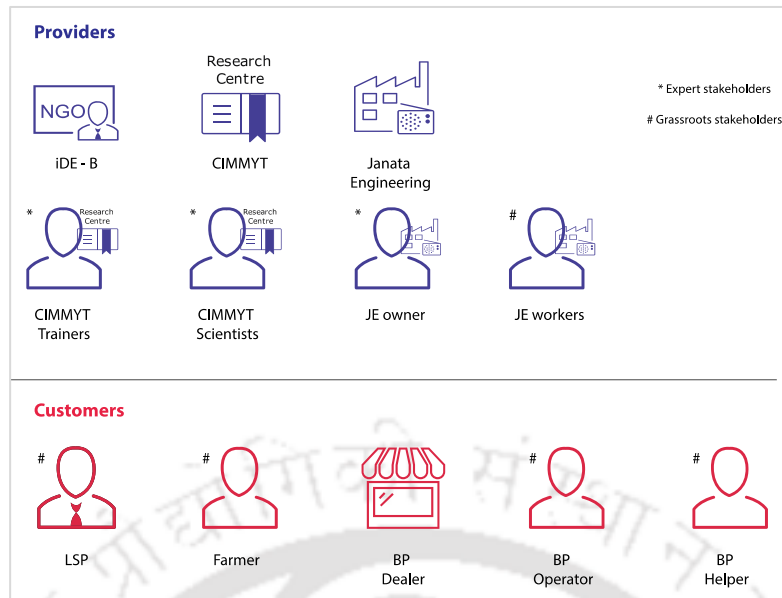

Figure 5.4. The expert and grassroots stakeholders who participated in the project data collection.

We conducted one-to-one unstructured interviews with expert stakeholders to map the problems, causes, and probable solutions according to their domain knowledge. Focus group discussions (FGD) with grassroots stakeholders helped map the problems, causes, and probable solutions with their tacit knowledge. FGD with both groups of stakeholders helped in the cross-pollination of viewpoints and thought processes. FGD sessions were conducted while operating the BP or while assembling and disassembling it to minimize the chances of missing on issues. It also encouraged the grassroots stakeholders to explain when they could not elaborate on it due to a lack of technical terminology knowledge. Three participatory design sessions were conducted involving both groups to pinpoint problems, prioritize them, identify causes and solutions, and draw up a feature list for the BP. One participatory design session with experts helped finalize the technical specification and feature prioritization. During the prototype building process, another participatory design session with JE workers helped improve the design and assembly plan with the workers' tacit and implicit knowledge. A mock training session clarified the nuances of training that needs to be worked upon to succeed in the BP-based PSS implementation. All sessions, except participatory design sessions with JE workers during manufacturing, were video recorded. Participatory design approach to designing is of utmost importance in S.PSS design. However, in the context of SAM design, the biggest hurdle in participatory design's way is a wide variety in the involved stakeholders' literacy, training, and experience. [Table 5.1](#) summarizes the methodology for data collection, the stakeholders involved, and the advantages and challenges.

Table 5.1. Summary of the data collection methodology, the stakeholders involved, and the advantages and challenges faced.

Source - Adapted from the published paper ([Banerjee and Punekar, 2020](#)). iDE-B staff supported in the data collection.

	Unstructured one-to-one Interviews	Focus Group Discussions	Participatory Design	Observational Research
Stakeholders Involved	CIMMYT agricultural scientists, iDE-B product manager, JE owner, BP dealer	¹ Farmers, LSPs, operators ² Farmers, LSPs, operators, trainers, agricultural scientists, iDE-B engineers and	⁴ JE owner and workers, farmers, LSPs, operators, agricultural scientists/ engineers/ trainers, iDE-B engineers, and sociologists	CIMMYT, JE workers, farmers, LSPs, operators

		sociologists, JE owner and workers ³ JE owner and workers, iDE-B engineers	⁵ Agricultural scientist and engineers with specializations in machine design & agronomy ⁶ JE workers	
Research set up (place & tools)	Stakeholders' office	¹ JE premises ² During field trials ³ At JE premises during assembly and disassembly of the BP.	⁴ CIMMYT office with the Frog Collective Action Toolkit (Frog, 2013) and Reframing Matrix (Morgan, 1993). ⁵ CIMMYT office ⁶ While prototyping the new BP at JE premises	During a mock-training session conducted by CIMMYT for JE workers, farmers, LSPs, operators.
Aim	To identify the problems, its causes, and solutions, as per the stakeholders.	¹ To identify the stakeholders' issues with the machine, causes and, probable solutions, and the features that will make the BP likable, desirable, and usable. ² To identify advantages, disadvantages, problems, probable causes, and solutions. ³ To identify engineering aspects of machine design, manufacturing, assembly, and maintenance.	⁴ To mutually ascertain problems, prioritize them, identify causes, desirable features, and ideate on solutions. ⁵ To finalize technical design requirements and specifications; deliberate on the feature list and priority matrix from ⁴ and confirm it. ⁶ To incorporate the JE workers' tacit and implicit knowledge for the BP design while prototyping and testing it.	To recognize the nuances of training operators and farmers. To design the content and mode of training.
Advantages	Experts gave us an overview of the problem at hand, the technical requirements, and specifications.	Grassroots and expert stakeholders' experiences, expertise, preferences, and scientific principles were assimilated into the design process.		BP's market performance due to training challenges became apparent.
Challenges	None	Conflicts arose due to the wide variety of stakeholder types and the resulting variations in knowledge, experience, interests, and needs from the project. Communication and discussion sessions were planned with care to achieve balance and equal expression opportunities during the sessions.		None

5.2.2. Results and discussion

The testing revealed three gap areas in MSDS (explained briefly in the subsequent sub-sections and [Appendix 4](#)). One was the lack of product design focus since MSDS lays focus on service and system design. Second, it lacked any metrics for evaluating sustainability in agriculture as it is a generic methodology, not designed considering the AM design context. Thirdly, the scenario demanded special attention to participatory design considering highly educated stakeholders like engineers and scientists and illiterate or semi-literate stakeholders like farmers and LSPs who possessed crucial practice-oriented knowledge. [Figure 5.5](#) summarizes the MSDS stages and processes, the gaps in them, and the redesigned sustainability-oriented design methodology, D-SAM framework I.

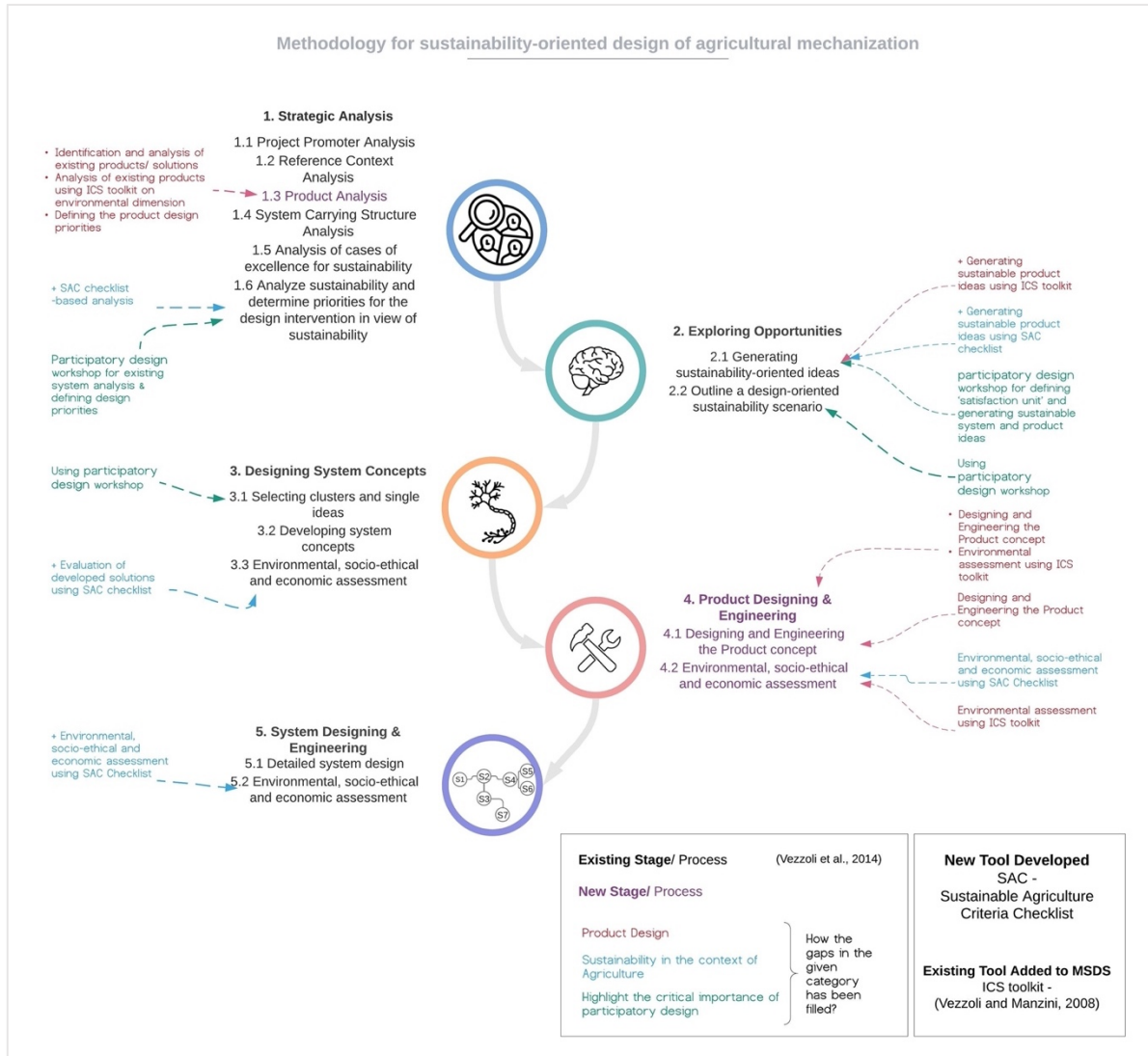

Figure 5.5. The flowchart shows the MSDS stages and processes, gaps, and the redesigned sustainability-oriented design approach for SAM achieved by filling the gaps. (adapted from published paper [\(Banerjee and Punekar, 2020\)](#))

To fill the product design focus gap, we added a product analysis process in *Stage 1: Strategic analysis*. The ICS toolkit aided analysis and ideation was incorporated while conducting *Stage 1: Strategic analysis* and *Stage 2: Exploring opportunities*, respectively. “Product designing and engineering” is introduced as the fourth stage, between *Stage 3: Designing system concepts* and *Stage 4: Designing and engineering system*, to stress the product design aspect of SAM design. The ICS toolkit aided evaluation of the redesigned product forms part of this stage.

For the second gap related to sustainability in the agricultural context, we designed a *Sustainable Agriculture Criteria Checklist (SAC)* and used it for strategic analysis, opportunity exploration, and product and system assessment.

For the third gap on participatory design approach stress, we incorporated it in the following three stages of MSDS: (1) *Strategic Analysis*, (2) *Exploring opportunities*, and (3) *Designing system concepts*. We did not integrate participatory design in the (new stage) product and (4) system design and engineering stages due to human resource constraints. Both stages need specialized domain knowledge and hence

is not deemed appropriate for participatory design with all stakeholders. [Figure 5.5](#) summarizes the redesigned sustainability-oriented design methodology. In the subsequent sections, we present the results and our conclusions on the efficacy and sufficiency of the MSDS and ICS toolkit as sustainability-oriented design supports for SAM design and how the said three gaps were identified and filled up. [Appendix 4](#) presents the full case study.

5.2.2.1. Stage 1: Strategic analysis

Here the goal is to secure contextual information, examine it for the context of sustainability, and set sustainability-oriented design targets. The five processes to achieve the same are: (1.1) *project promoter analysis and definition of intervention context*, (1.2) *reference context analysis*, (1.3) *system carrying structure analysis*, (1.4) *analysis of cases of excellence for sustainability*, and (1.5) *analyze sustainability & determine priorities for the design intervention concerning sustainability*. [Table 5.2](#) summarizes the processes in *Stage 1: Strategic Analysis*, results of using the processes and tools in it, gaps identified, and proposed addition. After that the next sub-sections elaborate the same.

Table 5.2. Processes in Stage 1: Strategic Analysis, results of using the processes and tools in it, gaps identified and proposed addition.

(* a represents new stage/ process/ tool, introduced in response to the gap identified).

Process	Process & tools in it helped	Results	Gap	Proposed addition
(1.1) Project promoter analysis and definition of intervention context	<ul style="list-style-type: none"> Identify stakeholders Understand their wants, needs, aspirations, and pains. Generates the system map with information, material, finance, and labor performance flow. 	<ul style="list-style-type: none"> Broadening of the sustainability-oriented design context and scope from BP's design to designing a bed planting S.PSS comprised of BP, a product strategy, training strategy for operators and manufacturers, and a supporting service and marketing strategy. 	Product Design focus lacking	Addition of (1.3) Product Analysis
(1.2) Reference context analysis	<ul style="list-style-type: none"> Identify engineering, human-centered design, ergonomics, logistics problems, and reasons for the system components' failure. Identify the strengths, weaknesses, opportunities, and threats. <ul style="list-style-type: none"> Generate an understanding of how individual functions, interactions, and stakeholders connect to generate a holistic design solution. 	<ul style="list-style-type: none"> The stakeholders co-designed the market definition, attributes, and features (categorized as "Must-be," "Attractive," and "Add-ons"). Identification of the unit of satisfaction as aspire-able bed planting The satisfaction unit is connected to the product and system specifications through instrumental value, psycho-social consequences, functional consequences, and abstract attributes. 		
(1.3) *Product Analysis	<ul style="list-style-type: none"> Articulate engineering and manufacturing requirements and shortcomings 	<ul style="list-style-type: none"> Environmental sustainability assessment of the existing product solutions. 	-	-

	<ul style="list-style-type: none"> • Generate inputs for *ICS Toolkit • Identify areas to conduct a technological macro-trend study 	<ul style="list-style-type: none"> • Setting the product design priorities following life cycle design strategies. 		
(1.4) System carrying structure analysis	<ul style="list-style-type: none"> • Identify macro-trends - social, economic, and technological 	<ul style="list-style-type: none"> • Report on the influence of the macro-trends on the case at hand. • Cues for product and system design for the case. 	–	–
(1.5) Analysis of cases of excellence for sustainability	<ul style="list-style-type: none"> • Identify other sustainability-oriented design solutions from the same field 	–	–	–
(1.6) Analyze sustainability & determine priorities for the design intervention concerning sustainability	<ul style="list-style-type: none"> • Analyze the social, economic, and environmental sustainability of the existing scenario • Set sustainability priorities for the design intervention 	<ul style="list-style-type: none"> • Analysis of the current scenario's sustainability • The setting of sustainability priorities for design intervention in agreement with the involved stakeholders. • Understanding trade-offs made while making a specific line of decisions. That provided cues for product and system design for the case and broadened the scope of the PSS. 	Sustainability in the agricultural context	Addition of toolkit: *SAC checklist
(1.6) + *SAC	<ul style="list-style-type: none"> • Aid the designer in checking sustainability in the agricultural context • Set sustainability priorities for the design intervention in the context of agriculture 			

(1.1) Project promoter analysis and definition of intervention context, (1.2) Reference context analysis

Application of processes (1.1) and (1.2) helped identify stakeholders and understand their wants, needs, aspirations, and pains. The tools prescribed in the process helped create the existing scenario's system map detailing the information, material, finance, and labor performance flow (details in section [A4.1.1](#)). This mapping helped us understand how individual interactions, functions, and stakeholders connect and affect each other. We also identified the engineering, human-centered, ergonomics, and logistics-related problems in the context and the root causes. All this information and the knowledge of the strengths, weaknesses, opportunities, and threats helped us broaden the sustainability-oriented design context and scope. Thus, the redesign assignment, which started as a task to redesign a BP, post the first two processes, was broadened to match SAM's context. The redesigned brief involved designing a bed planting S.PSS comprised of BP, a product strategy, training strategy for operators and manufacturers, and a supporting service and marketing strategy ([Figure 5.6](#)). The stakeholders co-designed the market definition, attributes, and features (categorized as “Must-be,” “Attractive,” and “Add-ons”) of the prospective bed planting S.PSS ([Banerjee, 2015](#)). The two processes aided in chalking an understanding of the system, its components, interactions, and energy flows effectively. However, product analysis tools are not part of this stage. AM being a product, product analysis is a must before we can proceed to (1.3) where the system's carrying structure is analyzed. Hence, an additional process, product analysis, is added. Thus, the new sequence of processes in stage 1 are: (1.1) *project promoter analysis and definition of intervention context*, (1.2) *reference context analysis*, (1.3) **product analysis**, (1.4) *system carrying structure analysis*, (1.5) *analysis of cases of excellence for sustainability*, and (1.6) *analyze*

sustainability & determine priorities for the design intervention concerning sustainability. The application of the processes (1.1) and (1.2) is presented in detail in section [A4.1.1](#).

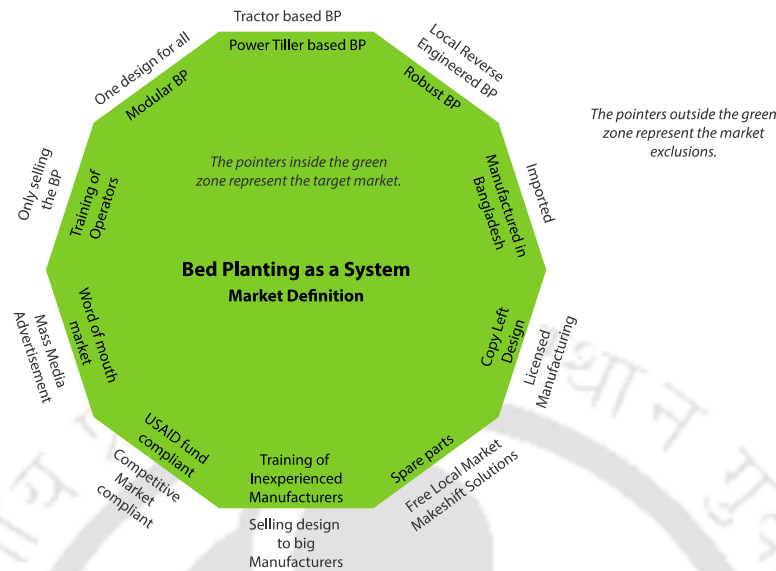

Figure 5.6. Market definition of the BP PSS co-designed by all stakeholders.

(1.3) Product analysis (Proposed addition to fill product design focus gap)

To bring product design focus to MSDS methodology, the product analysis process is introduced as the third process under *Stage 1: Strategic Analysis*. Herein, we studied the existing BP to identify the ergonomics, engineering and manufacturing requirements and shortcomings. The input so generated when fed into the ICS toolkit aided environmental analysis of the existing solutions (sample in [Figure 5.7](#)). After that, the design priorities for environmental sustainability were set using participatory design with the relevant stakeholders. The product analysis also helped identify areas in which technological macro-trends study has to be conducted as part of the next process, (1.4) *system carrying structure analysis*. For details, refer to section [A4.1.2](#).

(1.4) System carrying structure analysis

We identified the social, economic, and technological macro-trends in this process. For the technological macro-trend analysis, the BP was divided into functional sub-assemblies: the metering unit, the seed, and fertilizer dispensing unit, the soil pulverizing unit, and the bed shaping unit. For each of these functions, we identified competitive or more environment-friendly technologies and processes. These macro-trends were then used in *Stage 2: Exploring opportunities* and *Stage 4: Product designing and engineering* to ideate, design, and engineer the AM. The socio-economic issues identified during the FGDs and participatory design sessions were further investigated using literature research and used in *Stage 3: Designing system concepts* and *Stage 5: System designing and engineering*. For details, refer to section [A4.1.3](#).

(1.5) Analysis of cases of excellence for sustainability

Here the designer is supposed to identify other sustainability-oriented design solutions from the same field and use them to get inspired and, after that, the designer also compares them against the redesigned solutions (in the last stage). Literature research presented in [Chapter 4](#) shows no literature with a holistic view of sustainability for AM design. As a result, we could not perform this process.

USE EXTENSION/INTENSIFICATION

CHECKLIST

1. IS THE PRODUCT/SYSTEM A DISPOSABLE ONE (USED ONLY ONE TIME, EXCLUDING CONSUMABLES)?
2. IS THE PRODUCT/SYSTEM WITH SHORT LIFE-SPAN (EXCLUDING CONSUMABLES)?
3. ARE DISPOSABLE PACKAGING USED?
4. DOES THE PRODUCT/SYSTEM, OR SOME OF ITS SOME PARTS, TEND TO WEAR OUT EASILY?
5. IS THE PRODUCT/SYSTEM DIFFICULT TO BE MAINTAINED, REPAIRED AND/OR UPGRADED?
6. DOES THE PRODUCT/SYSTEM TEND TO BE TECHNOLOGICALLY OBSOLETE?
7. DOES THE PRODUCT/SYSTEM TEND TO BE CULTURALLY/AESTHETICALLY OBSOLETE?
8. DOES THE PRODUCT/SYSTEM REMAIN UNUSED FOR LONG PERIODS OF TIME?
9. IS THE PRODUCT/SYSTEM INDIVIDUALLY USED, WHEN IT COULD BE SHARED IN SOME OF ITS PARTS?
10. OTHER?

PRIORITY
HIGH

EVALUATION (write here the answers as a report, i.e. detailing the problems)

The fasteners (nuts and bolts) and the chain and sprocket mechanisms used were of low quality. The fasteners would loosen or break after a few fastening and unfastening operation. They were also damaged during use. Since they could not be tightened optimally, they loosen, resulting in the break down during usage. The chain elongated during usage and kept slipping, resulting in seed drop misses.

The plastic precision seeds metering plates warped in the sun. The small seeds then got stuck in the gap created and caused its breakage.

The rotary blades were bought from China, modified with improper heat treatment. As a result, blade life was low.

It was not designed considering hard soils. The machine, thus, always broke under such circumstances.

The lifespan of the 2WT on which the BP will be built has a short life of 3 - 5 years. Post that, it is not useful for agricultural work.

The users wanted to own and use tractor-like powerful machines and thought of BP as obsolete and less capable.

USE INT./EXT. P: HIGH

MATERIAL RED. P: HIGH

ENERGY REDUC. P: HIGH

MAT. LIFE EXT. P: HIGH

TOXITY REDUC. P: HIGH

RES. CONS. P: HIGH

Figure 5.7. Sample environmental sustainability analysis and priority setting using the ICS toolkit.

(1.6) Analyze sustainability & determine priorities for the design intervention concerning sustainability

We involved all the stakeholders using a participatory design approach to analyze the existing scenario's sustainability and determine design intervention priorities using the “SDO toolkit - checklist existing system” (sample in [Figure 5.8](#)). The analysis brought forth the sustainability concerns and trade-offs that we might have to make while adopting a specific line of design decisions. For example, BP can be entirely manufactured in Bangladesh. That can strengthen the country's small and medium enterprises sector, offer quality products at competitive prices, give the pride of being “Made in Bangladesh” to its citizens, and proximity to the users can help design better locally adapted technology. However, the country lacked quality manufacturers at the scale at which BP was to be manufactured. BP being an attachment to a third party 2WT (that too imported) was always a long-term business risk. However, developing an in-house 2WT was not at all economically viable. The trade-off knowledge was used during the PSS ideation and detailing phase and broadened the PSS scope. For details, refer to section [A4.1.5](#). Post the analysis, we concluded that the results from the environmental dimension of the “SDO toolkit - checklist existing system” could reveal all the product-related environmental issues along with those for the system and services. Hence, the ICS toolkit-aided analysis may be dropped from the process (1.3), or one can do the analysis and then add the data to the SDO toolkit in the process (1.6).

Sustainable Agriculture Criteria (SAC) Checklist

(Proposed addition to fill the gap sustainability in the agricultural context)

The ICS toolkit aided in the environmental sustainability assessment and priority setting for SAM's product part following an LCD approach. The SDO toolkit supported sustainability assessment and priority setting for design intervention on all three dimensions for the entire PSS. However, as both tools are not specifically designed for agriculture, they cannot check the sustainability impact of SAM from an agronomic perspective. Thus, we designed the SAC checklist that can be used by a SAM designer to assess sustainability and set sustainability-oriented design priorities in the agricultural context. The next section presents the SAC checklist and its three-pronged development approach.

The screenshot shows the SDO Sustainability Design-Orienting Toolkit interface. On the left is a navigation menu with sections: PROJECT RECORD, Sustainability Dimension (Environmental, Socio-Ethical, Economic), and Radars (Environmental, Socio-Ethical, Economic). The 'Socio-Ethical Sustainability' section is active, with 'Analyse & Set Priorities' selected. The main content area is titled 'Power Tiller based Bed plant' and includes a 'Socio-Ethical Sustainability - Analyse & Set Priorities' section. It features a checklist for an 'Existing System' with three items: 'Improve employment and working conditions', 'Improve equity and justice in relation to stakeholders', and 'Enable a responsible and sustainable consumption'. Each item has a priority selector (N, L, M, H) and a 'Check list' checkbox. A text area on the right contains a detailed description of the system's issues, such as difficulty lifting the planter, operator fatigue, dust, vibrations, and safety hazards.

Figure 5.8. Socio-ethical sustainability analysis and priority setting using the SDO toolkit - checklist existing system.

5.2.2.2. Sustainable Agriculture Criteria checklist development

Literature suggested a three-pronged approach to develop the SAC checklist.

1. Multidisciplinary & integrated approach

Researchers ([Gliessman, 1987](#); [Lockeretz, 1991](#); [Macrae et al., 1990](#); [Park and Seaton, 1996](#)) suggest a multidisciplinary and integrated approach to sustainable agriculture research. Thus, the research approach has to deliberate on the interactions between the component disciplines and identify the links and the overlaps ([Lockeretz, 1991](#)). [Park and Seaton \(1996\)](#) described an integrated approach with three interface levels: (1) socio-economic theory in conjunction with scientific theory describes the ecological sustainability concept; (2) linking the stakeholders' (those responsible for bringing the desired change in the system) attitudes and behavior with the ecological processes; and (3) linking the policy issues with the actions and perceptions of the stakeholders mentioned in (2). ([Lockeretz, 1991](#); [Park and Seaton, 1996](#)) Consequently, a design team involved in designing for sustainable agriculture needs experts from multiple disciplines. It also needs individuals experienced in bridging communication between stakeholders and the scientific and social disciplines. To develop the SAC checklist for the case study, we used the integrated approach with three interface levels, as suggested by [Park and Seaton \(1996\)](#), and secured a multidisciplinary team of experts to brainstorm on the checklist criteria. We consulted experts from AM engineers, soil science, agronomy, and sociology.

2. Vertical and horizontal systems interaction

Sustainable agricultural systems' framework needs consideration of interactions between the vertical and the horizontal systems ([Park and Seaton, 1996](#)). A discussion with the experts involved in the project helped identify the vertical systems for the case as AM, agricultural, vocational training, service, manufacturing, and energy systems. The horizontal systems identified were physical (soil, air, other lifeforms), social (labor, gender, health, safety), economic (subsidies, costs), and political system (endorsements, subsidies, aids). [Figure 5.9](#) showcases the vertical and horizontal systems.

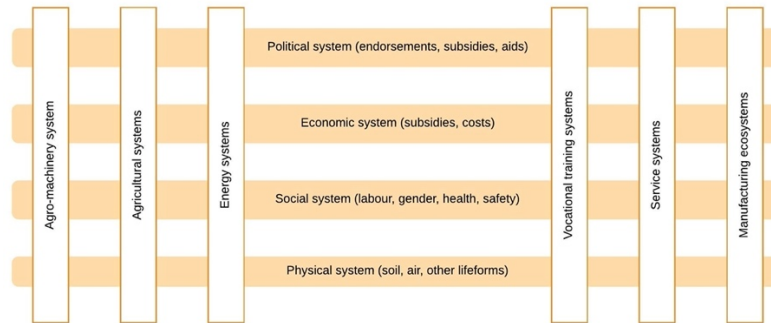

Figure 5.9. Vertical and horizontal systems for the case.

3. Balancing the short-term and long-term implications to create possible sustainable pathways

Bio-geophysical processes involved in agriculture are long-term processes and are beyond the control of short-term human activities. Thus, pathways within the viability and sustainability space of a system need to be identified [Park and Seaton \(1996\)](#). [López-Ridaura \(2002\)](#), who designed the MESMIS approach²⁴ for Mexico and Latin America, also argued that short-term oriented economic and agronomic indicators like maximizing yield and benefit/ cost ratios are used. However, to achieve sustainability, both the scientific and the development sectors agree on the need to include long-term oriented economic, social, environmental, and agronomic indicators. Hence, our multidisciplinary team identified short-term and long-term implications and objectives and the possible sustainable pathways ([Figure 5.10](#)). The viable shorter-term objectives were reducing farm labor dependence, soil preparation and sowing cost, mechanized bed planting, alternate employment generation, and manufacturing capability enhancement. The desirable long-term objectives were establishing permanent beds, conservation agriculture, gender-neutral machine operations, and a robust ecosystem for 2WT operated AM in Bangladesh.

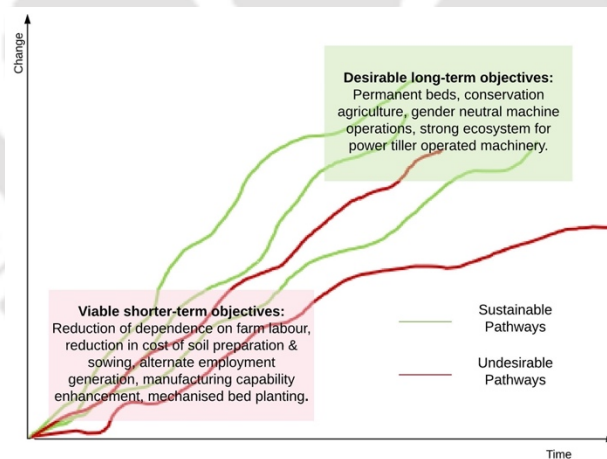

Figure 5.10. Identification of pathways to navigate through short-term and long-term viable sustainability objectives.

Using the three-pronged approach, the SAC checklist ([Table 5.3](#)) was drawn. SAC was then used to analyze the current scenario's sustainability from a sustainable agriculture perspective and to set sustainability priorities for design intervention in agreement with the involved stakeholders (through participatory design). It further enhanced our understanding of trade-offs being made while making a

²⁴ a "systemic, participatory, interdisciplinary and flexible framework for evaluating sustainability" in the context of peasant agriculture and peasant Natural Resource Management Systems

specific line of decisions. This provided cues for product and system design for the case and broadened the scope of the PSS. Like the SDO and ICS toolkit, the SAC checklist consists of criteria and sub-criteria, and contextually appropriate priority can be set for each criterion.

Table 5.3. Sustainable Agriculture Criteria (SAC) checklist

Source - Adapted from the published paper ([Banerjee and Puneekar, 2020](#)).

Criteria	Sub-criteria
Short-term & immediate effect on	soil health; air health; water health; the crop/ plant/ tree/ produce; other life forms like earthworms, bees, insects, birds, rodents, etc.; others
Long-term effect on	soil health; air health; water health; the crop/ plant/ tree/ produce; other life forms like earthworms, bees, insects, birds, rodents, etc.; others
Bearing of the AM on the agro-system activities	soil preparation; planting or seeding; fertilizing or nutrient adding; weeding/ adding pesticides/ insecticides; plant care activities; harvesting; post-harvesting; others
Impact on sustainable farming practices	conservation farming; organic fertilizing; organic farming; intercropping; others
Auto-optimization of functioning based on	soil moisture; soil nutrients; soil structure; crop type; others
Machine Typology Efficiency concerning the	human energy required; machine energy required; purpose; others
Impact on __ due to the AM induced pre-processing needs	labor/ machine preparatory operation/ process/ product/ service/ system requirement/ others
Impact on __ due to the AM induced post-processing needs	labor/ machine preparatory operation/ process/ product/ service/ system requirement/ others
Influence of the workforce on the AM	design and development team; manufacturer's expertise, infrastructure, spending power, etc.; the literacy level of the labor force on the decision to use/ purchase, usage, repair, maintenance, and disposal; training level of users; users' perception and experience on the decision to use/ purchase, usage, repair, maintenance, and disposal; gender and age on the decision to use/ purchase, usage, repair, maintenance, disposal.
Influence of the AM on workforce	literacy level; training level; perception; experience; gender/ age/ status; others
Health & Safety	Health/ accident dangers during usage/ storage/ transport of the AM? When operating the AM, is it possible to use protective gear? Others?
Finance	Will the consumer need financial support for buying the AM? Will that financial assistance be accessible and affordable? Is the financial debt repayable by using the AM with the revenue generated? Is subsidy or assistance from the government or in some other form available? Is help available to the customer for the selection of the ideal AM package? Are economic assistance available for the AM's operation and repair costs? Does the landholding size influence the AM operation and lucrativeness?
End-of-life	Will the AM have significance for other uses post its primary use-life? Does a particular disposal approach (like scrap value) help the user?
Impediments due to infrastructure	Are there barriers due to physical infrastructure? Are stakeholders aware of the barriers? Are there other infrastructure barriers?
Reduction in	seed wastage, fertilizer use, pesticide use, and its damaging impact on the people and planet; wastes and emissions; time for completion of activities; farm labor use and drudgery of farm laborers; child labor; cost?

Addition to process (1.6): SAC checklist-aided assessment (Proposed addition to fill the gap sustainability in the agricultural context)

After drawing out the SAC checklist, we assessed the current scenario using it and set the design priorities (for details refer section [A4.1.6](#)). Therefore, the process (1.6) in the sustainability-oriented design methodology for SAM now consists of the following sub-processes:

- ♦ Analyze the existing scenario's social, economic, and environmental sustainability using the *SDO toolkit - checklist existing system*.
- ♦ Set sustainability priorities for the design intervention in the *SDO toolkit - checklist existing system*.
- ♦ Analyze the existing scenario's social, economic, and environmental sustainability in the agricultural context using the SAC checklist.
- ♦ Set sustainability priorities for the design intervention in the context of agriculture using the SAC checklist.

Stage 1: Strategic analysis, thus, concluded with the setting of the following sustainability priorities for the design intervention.

Table 5.4. Summary of priorities set for the project.

Dimension	Criterion	Priority
Environmental Sustainability	System life optimization	High
	Transportation/ distribution reduction	High
	Resource reduction	High
	Waste minimization/ valorization priority	Low
	Conservation/ biocompatibility	No
Socio-Ethical Sustainability	Toxicity Reduction	Medium
	Improve employment and working conditions	High
	Improve equity and justice in relation to stakeholders	High
	Enable a responsible and sustainable consumption	High
	Favor/ integrate weaker and marginalized strata	Medium
Economic Sustainability	Improve social cohesion	No
	Empower/ valorize local resources	High
	Market position and competitiveness	High
	Profitability/ added value for companies	Medium
	Added value for customers	High
Impact on Agricultural Practice	Long term business development/ risk	Low
	Partnership/ cooperation	High
	Macro-economic effect	No
	Short-term & immediate effect	Medium
	Long term effect	No
	Bearing of the AM on the agro-system activities	Medium
	Impact on sustainable farming practices	No
	Auto-optimization of functioning	No
	Machine Typology Efficiency	High
	Impact due to the AM induced pre-processing needs	High
Impact due to the AM induced post-processing needs	Medium	
Health & Safety	Influence of the workforce on the AM	High
	Influence of the AM on workforce	High
	Health & Safety	High
Finance	Medium	

	End-of-life	No
	Impediments due to infrastructure	High
	Reduction in	Low

The redesigned *Stage 1: Strategic analysis* can be summarized as in [Figure 5.11](#).



Figure 5.11. Redesigned Stage 1: Strategic Analysis.

5.2.2.3. Stage 2: Exploring opportunities

This stage aims to generate ideas for sustainable services and systems, cluster them, and expand them. The two processes to achieve the same are (2.1) *generating sustainability-oriented ideas* and (2.2) *outline a design-oriented sustainability scenario*. [Table 5.5](#) summarizes the processes in *Stage 2: Exploring Opportunities*, results of using the processes and tools in it, gaps identified and proposed addition.

Table 5.5. Processes in Stage 2: Exploring opportunities, results of using the processes and tools in it, gaps identified, and proposed addition.

(* a represents new stage/ process/ tool, introduced in response to the gap identified).

Process	Process & tools in it helped	Results	Gap	Proposed addition
(2.1) Generating sustainability-oriented ideas	<ul style="list-style-type: none"> • Generate ideas for service and system levels • Cluster and expand the ideas 	<ul style="list-style-type: none"> • PSS Satisfaction unit and the sub-satisfactions • Sustainability – oriented conceptual scenarios 	Product Design focus lacking Sustainability in the agricultural context	*ICS toolkit ideas board and the *SAC checklist for generating sustainability-oriented ideas
(2.1) + *ICS toolkit ideas board and the *SAC checklist for generating sustainability-oriented ideas	<ul style="list-style-type: none"> • Generate ideas for product level • Generate ideas for sustainable agriculture 		–	–
(2.2) Outline a design-oriented sustainability scenario	<ul style="list-style-type: none"> • Map the conceptual scenarios generated in (2.1) on polarity diagrams using polar sustainability scenarios for the system 	<ul style="list-style-type: none"> • Outlines of design-oriented sustainability scenarios 	–	–

(2.1) Generating sustainability-oriented ideas

The stakeholders together first outlined the PSS's satisfaction unit and the sub-satisfactions. The project's satisfaction unit was defined as effective bed planting, where effective is defined as timely, cost-efficient, and high-quality performance for the farmers, LSPs, and operators. Next, all stakeholders used the "*SDO Toolkit – orient the concept*" to generate sustainable service and system ideas (sample in [Figure 5.12](#), full ideation in section [A4.2.1](#)). The stakeholders were brought in together for the ideation process through the participatory design sessions. Some of these sessions were conducted only with

experts, while others had a mixed group consisting of both experts and grassroots stakeholders. [Table 5.1](#) presents the details of these participatory design sessions. The SDO toolkit's ideation cues aided in ideation at the system level and for the PSS's service components on all three sustainability dimensions. However, the SDO toolkit provided no focused guidelines for product design and DfS for the agricultural context.

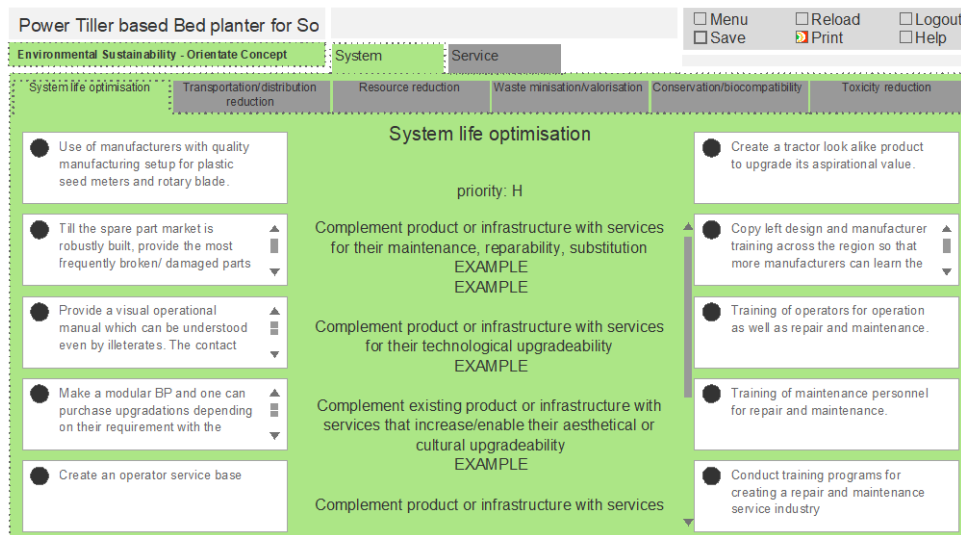

Figure 5.12. Generating sustainability-oriented ideas using the SDO toolkit - orient the concept.

Generating sustainability-oriented ideas using the ICS and SAC ideas board (Proposed addition to fill the gap - product design focus, sustainability in the agricultural context)

We used ICS toolkit's eco-ideas board to generate environment-friendly product ideas using the LCD approach. The SAC ideas board helped in generating product and process ideas conducive to achieving sustainable agricultural solutions. In this case, the ideation was also conducted using the participatory design sessions with experts and grassroots stakeholders. Since the SAC checklist was designed as an assessment tool, unlike the SDO and ICS toolkit's ideation support boards, it did not possess ideation cues. Hence, we saw the need for an ideation support board, similar to SDO and ICS toolkit, for aiding with design cues for sustainability in the agricultural context. A sample of the ICS ideas board aided ideation is presented in [Figure 5.13](#) and the full ideation in section [A4.2.2, Table A4.7](#). Using the SAC ideas board, a sample of idea generation is presented in [Figure 5.14](#) and the full ideation in section [A4.2.2, Table A4.8](#).

In [\(1.6\) Analyze sustainability & determine priorities for the design intervention concerning sustainability](#) we identified that the ICS and SDO toolkit aided analysis on the environmental dimension overlapped. The results obtained from the ICS toolkit were a subset of the ones obtained from the SDO toolkit. Hence, in the analysis phase, one can choose to use only the SDO toolkit. In this section, post idea generation using the ICS and SDO toolkit, we conclude that the ICS toolkit is more effective in product level ideation while the SDO toolkit for system and service levels. Hence, for idea generation, both toolkits complement each other.

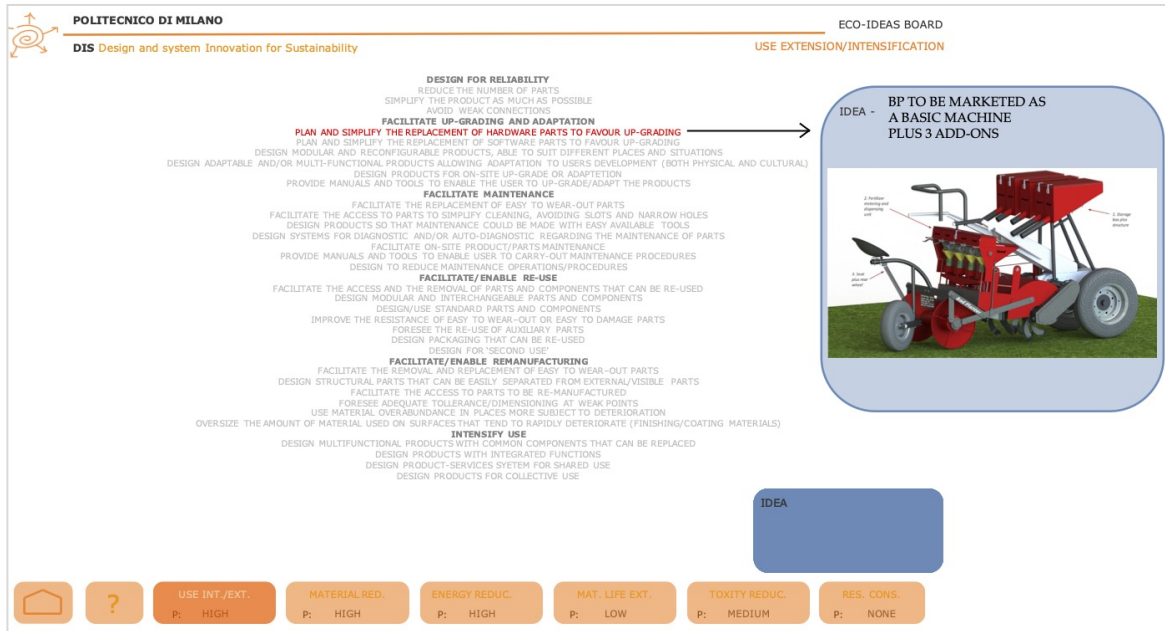

Figure 5.13. Generating sustainability-oriented ideas using the ICS toolkit – eco-ideas board (a sample).

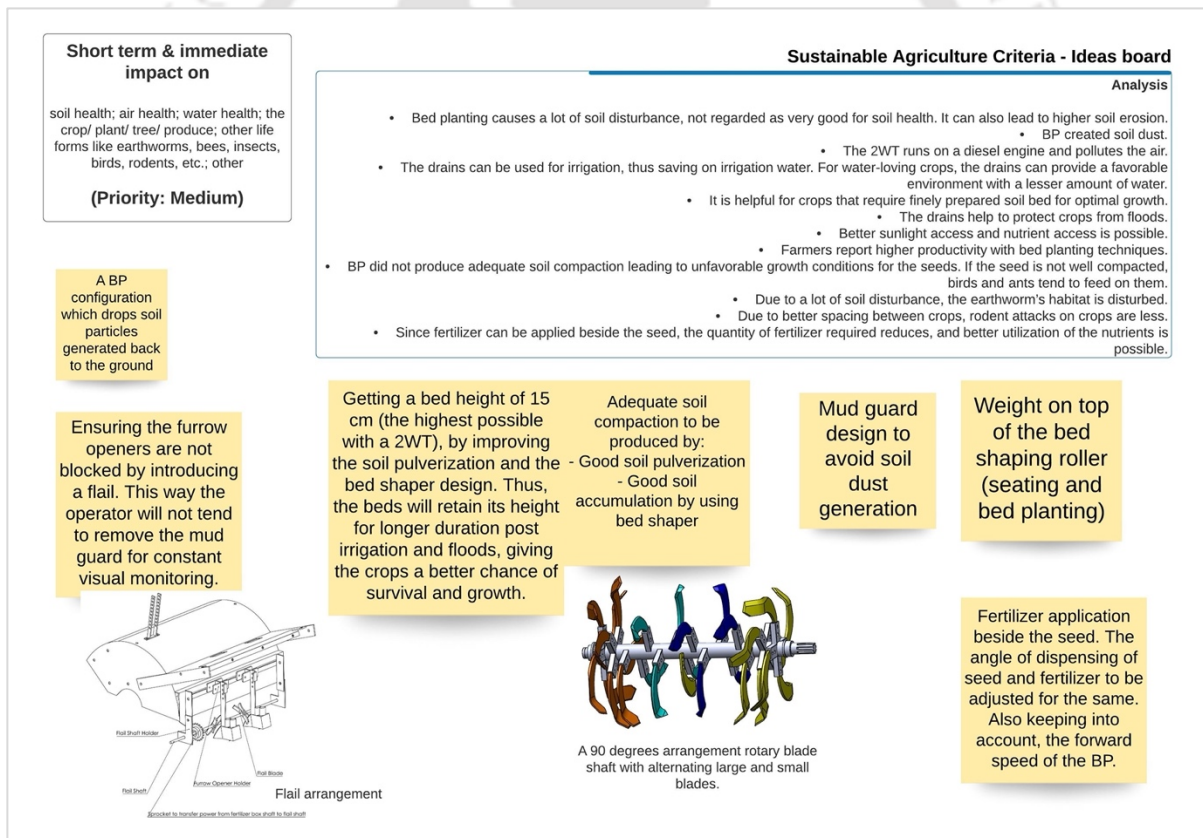

Figure 5.14. Sample of idea generation using the SAC ideas board.

(2.2) Outline a design-oriented sustainability scenario

Post idea generation using the *SDO Toolkit – orient the concept, ICS toolkit ideas board*, and the SAC ideas board, the ideas were clustered into groups. Polar ideas like local manufacturing versus precision manufacturing (import scenario) (Figure 5.15) were identified. That helped generate several conceptual scenarios (sample PSS concept in Figure 5.16). Those were mapped on polar sustainability scenarios for the system (Figure 5.17). We, thus, created outlines for design-oriented sustainability scenarios using

the knowledge expansion generated through the polarities diagrams and a study of their pros and cons on the system's sustainability. For details, refer to section [A4.2.3](#).

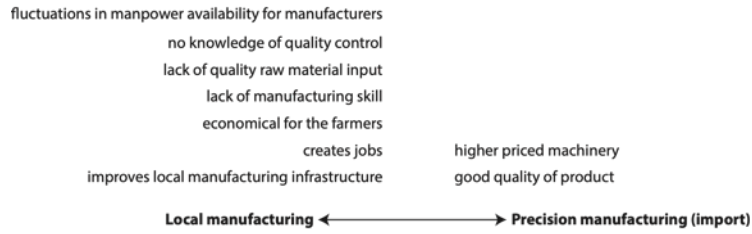

Figure 5.15. Sample polar ideas.

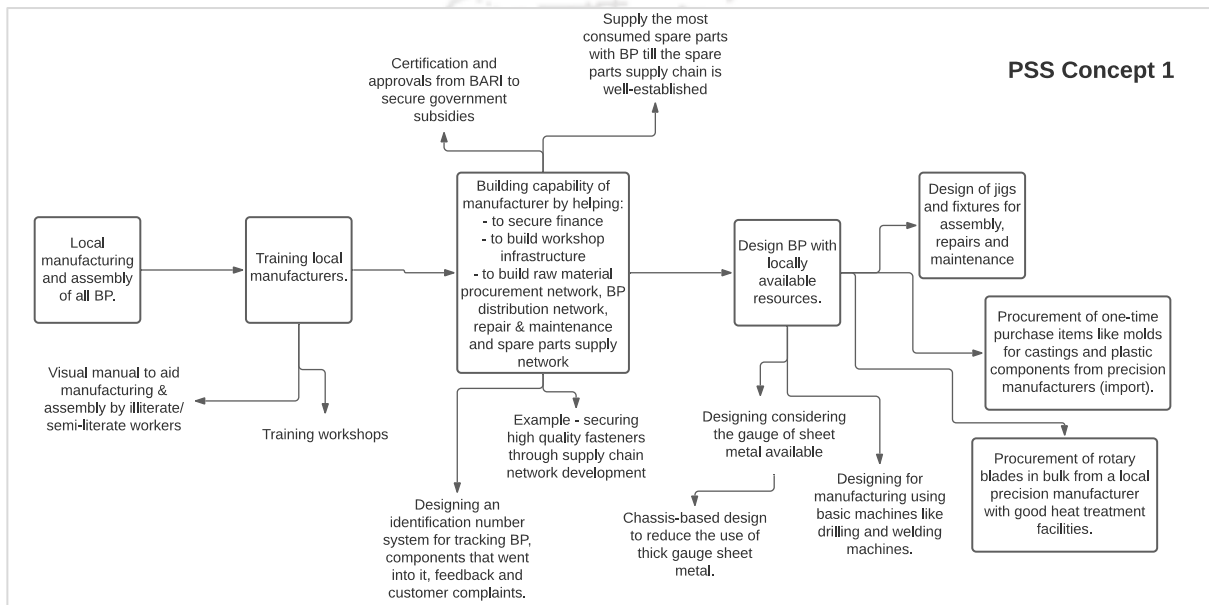

Figure 5.16. PSS concept 1 considering local manufacturing and assembly of BP.

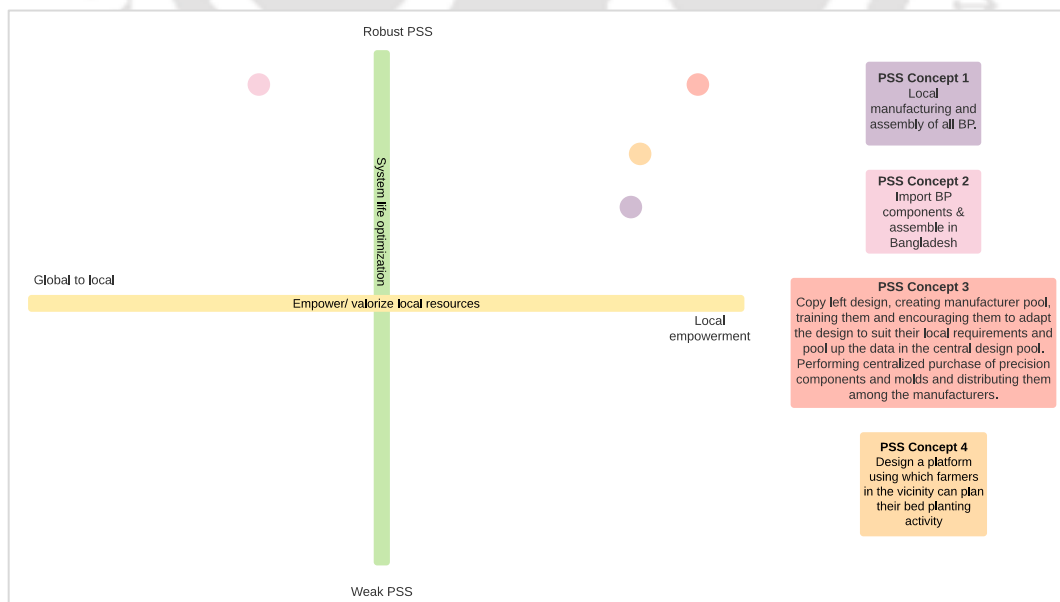

Figure 5.17. Sample polarities diagram.

The redesigned *Stage 2: Exploring opportunities* can be summarized as in [Figure 5.18](#).

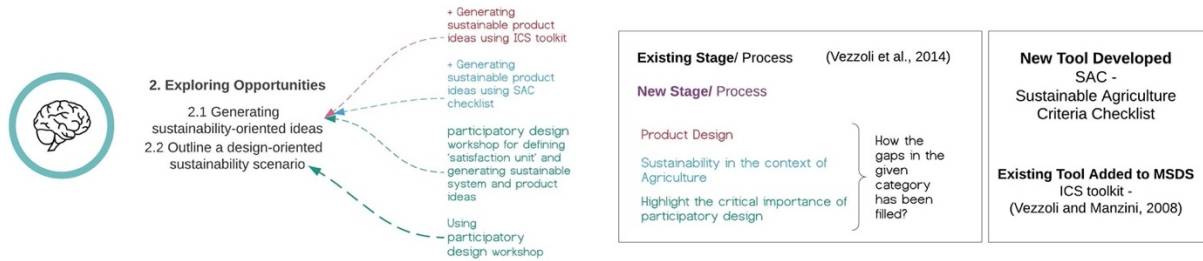

Figure 5.18. Redesigning Stage 2: Exploring opportunities.

5.2.2.4. Stage 3: Designing system concepts

This stage aims to design system concepts using the design-oriented sustainability scenario outlines from (2.2), design the stakeholder and systems map for each concept, and assess them on the three sustainability dimensions. The three processes for this stage are (3.1) *selecting clusters and single ideas*, (3.2) *developing system concepts*, (3.3) *environmental, socio – ethical, and economic assessment*. Table 5.6 summarizes the processes in Stage 3: Designing System Concepts, results of using the processes and tools in it, gaps identified, and proposed addition.

Table 5.6. Processes in Stage 3: Designing system concepts, results of using the processes and tools in it, gaps identified, and proposed addition.

(* a represents new stage/ process/ tool, introduced in response to the gap identified).

Process	Process & tools in it helped	Results	Gap	Proposed addition
(3.1) Selecting clusters and single ideas	<ul style="list-style-type: none"> Plot possible conflicting directions from the polarities identified in (2.2) on quadrants Select the most promising scenarios or idea clusters considering user acceptability, technological and economic feasibility Make informed trade-off decisions considering the possible (un)sustainability arising from a particular line of design decisions 	<ul style="list-style-type: none"> Identification of most promising design scenarios and a cluster of ideas for further development Identification of trade-off decisions 	-	-
(3.2) Developing system concepts	<ul style="list-style-type: none"> Define possible PSS concepts, stakeholder interactions, offering diagram consisting of the core functions, the basic functionalities, the added-value functionalities, and the sub-functionalities 		-	-
(3.3) Environmental, socio-ethical, and economic assessment	<ul style="list-style-type: none"> Describe the improvements Qualitative assessment on three dimensions of sustainability for improvement or worsening Visualization of the assessment on radar diagrams 		<ul style="list-style-type: none"> Sustainability in the agricultural context 	*SAC checklist aided assessment
(3.3) + *SAC checklist aided assessment				

MSDS stages 1 to 3 + the add-ons	<ul style="list-style-type: none"> • System concepts • Service concepts • Product ideas 	<ul style="list-style-type: none"> • PSS concepts with a focus on system and service level 	<ul style="list-style-type: none"> • Product Design focus • PSS and product sustainability in the agricultural context 	Addition of *Stage 4: Product designing and engineering
-------------------------------------	--	---	--	---

(3.1) Selecting clusters and single ideas

First, possible conflicting directions, as obtained from the polarities identified in (2.2), were plotted on quadrants of polarity diagrams (Figure 5.17). We selected the most promising design-oriented sustainability scenarios and idea clusters with an eye on user acceptability, technological and economic feasibility. The PSS stakeholders made decisions regarding the selection of the scenarios and idea clusters during the participatory design sessions. The polarities diagrams enabled us to make more informed trade-off decisions considering all the possible (un)sustainability arising from a particular line of design decisions. The diagrams also facilitated designing the offering diagrams explained in (3.2). For details, refer to section A4.3.1.

(3.2) Developing system concepts

We defined possible PSS concepts from the promising design-oriented sustainability scenarios and idea clusters identified in (3.1). For each of the possible PSS concept, stakeholder interactions were defined. Figure 5.19 shows the final PSS stakeholders, and Figure 5.20 shows the energy flows between the stakeholders. The offering diagram (Figure 5.21), which defines the core functions, the basic functionalities, the added-value functionalities, and the sub-functionalities for a PSS, was constructed using the trade-off decision knowledge gathered through the polarity diagrams. The core functions consist of the PSS's most critical functions, which define its unique value propositions. The basic functionalities are required to offer the core functionalities. PSS is enriched, and its value is augmented due to the added-value functionalities. These are also connected to the PSS's core functionalities. The sub – functionalities describe how PSS functionalities will be delivered to its customers. For details, refer to section A4.3.2.

(3.3) Environmental, socio-ethical and economic assessment

Herein the “SDO toolkit - checklist concept” was used to describe the improvements made in each of the PSS concepts developed in (3.2). After that, a qualitative assessment of the redesigned PSS concepts was done on all three sustainability dimensions per the stakeholders' priorities set at the beginning of the project. The SDO toolkit aided the visualization of the qualitative assessment using radar diagrams. Due to time and human resource constraints, the assessment was done by the researcher only. Some PSS stakeholders' involvement in the assessment process could have provided better visualization of the improvements and worsening. Figure 5.23 shows the radar diagrams for the final PSS. For details, refer to section A4.3.3. The most prospective PSS concept was thus selected for further detailing under Stage 5: System designing and engineering to achieve the final PSS design as represented by Figure 5.19, Figure 5.20, and Figure 5.21.

Addition to (3.3): SAC checklist-aided assessment

(Proposed addition to fill the gap sustainability in the agricultural context)

The PSS design, the stakeholder interactions in it, and the functional offerings will impact the agronomic sustainability on all three dimensions. Since SDO Toolkit has no scope for a sustainability impact assessment on the agronomic aspects, we used the SAC checklist to assess the PSS concepts. We also visually represented the results on a radar diagram (Figure 5.23).

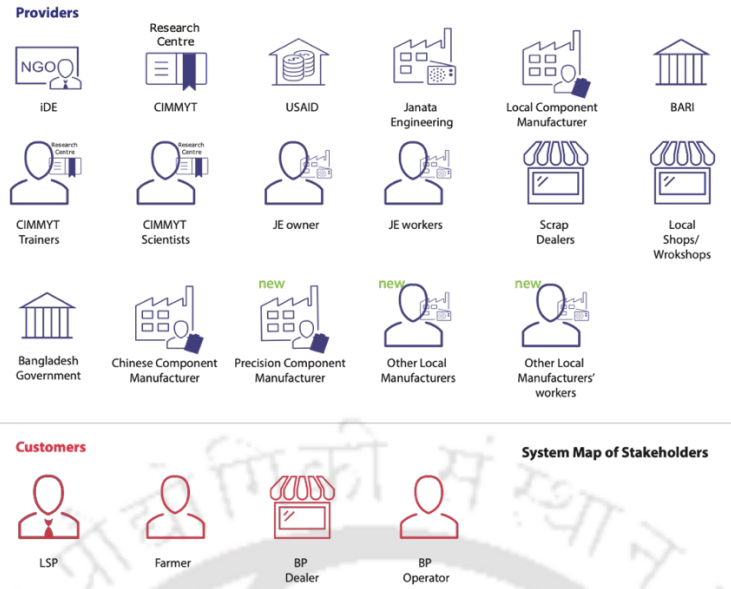

Figure 5.19. Stakeholders of the final PSS.

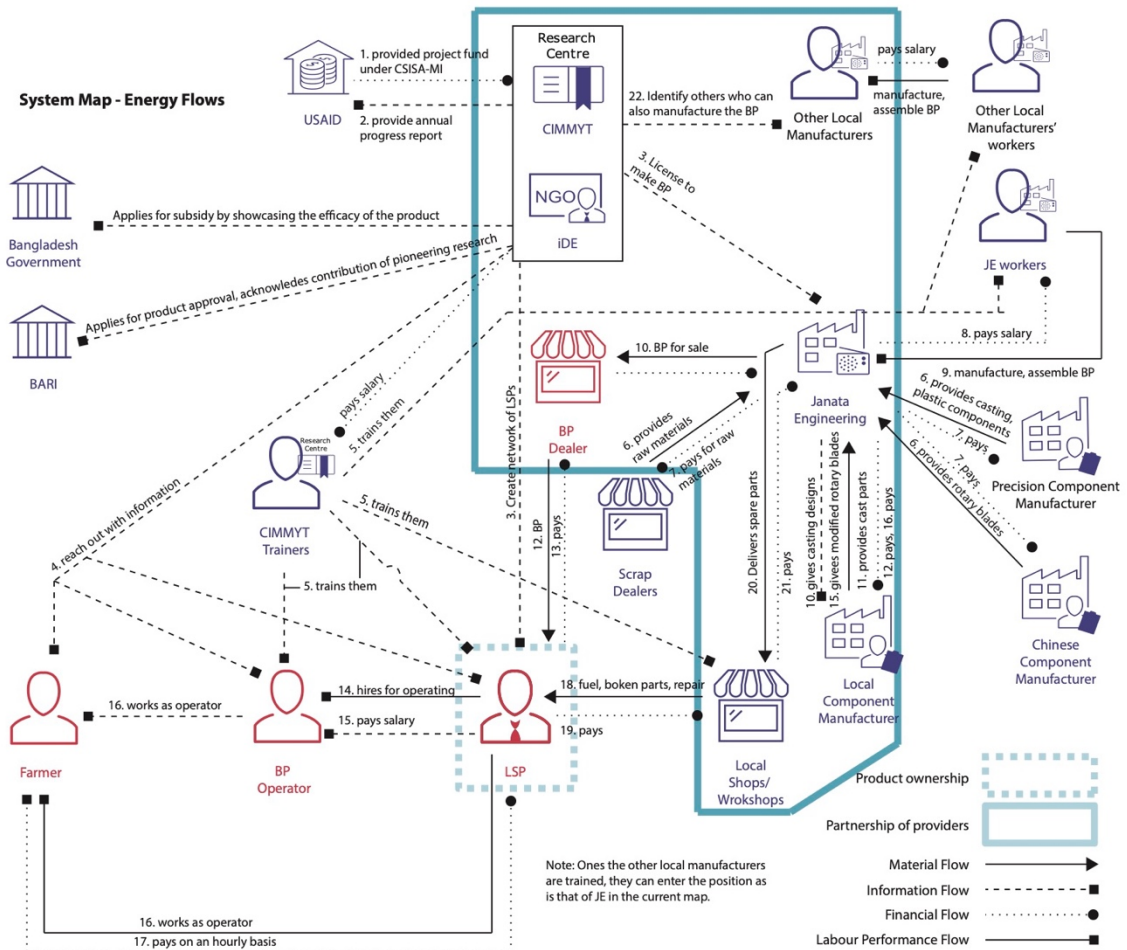

Figure 5.20. Energy flows between the stakeholders in the final PSS.

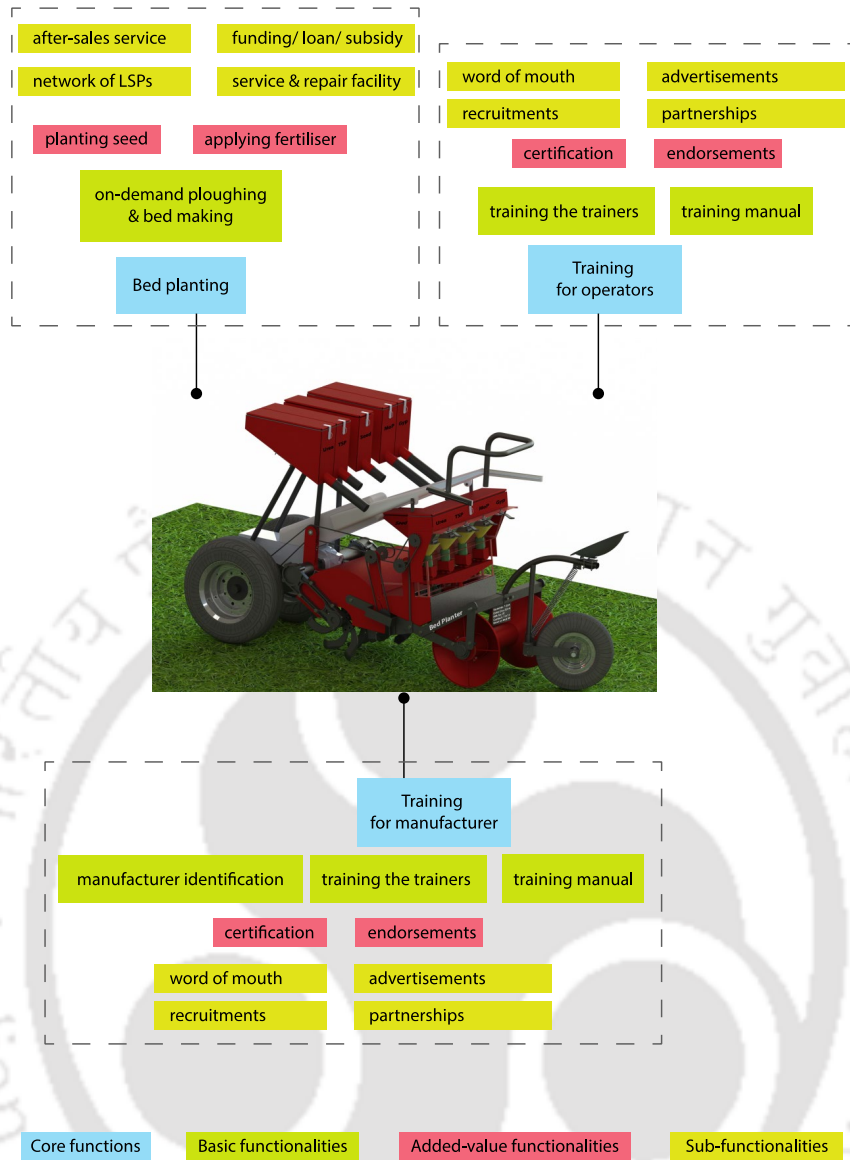

Figure 5.21. Offering diagram for the final PSS.

The redesigned *Stage 3: Designing system concepts* can be summarized as in [Figure 5.18](#).



Figure 5.22. Redesigned Stage 3: Designing system concepts.

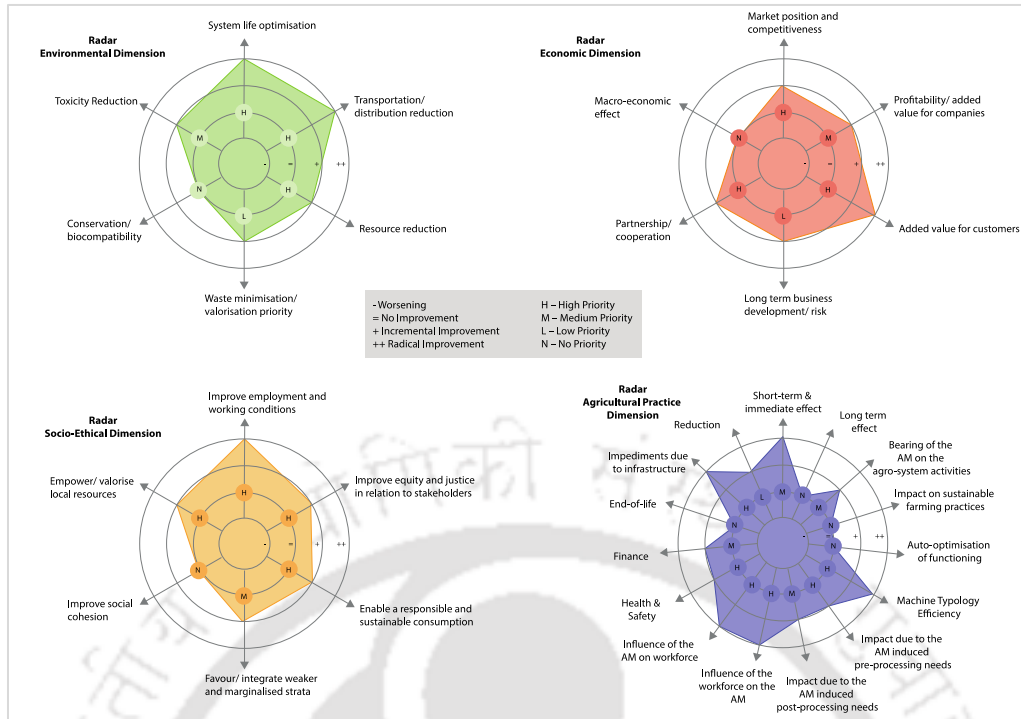

Figure 5.23. Visualizing the expected sustainability improvements alongside the priority for each criterion using radar diagrams for the final PSS.

5.2.2.5. Stage 4: Product designing and engineering (New Stage)

(Proposed addition to fill the gap - product design focus, sustainability in the agricultural context)

Since SAM's design requires designing the AM with an LCD approach for environmental sustainability, we incorporated a new stage in MSDS, called Stage 4: Product designing and engineering. This stage aims to design and engineer the BP and conduct sustainability assessment of the redesigned BP using the ICS toolkit and the SAC checklist. *Stage 3: Designing system concepts* and *Stage 4: Product designing and engineering* went hand-in-hand during the design process as the product's design influence the PSS concept and vice versa. However, we choose to present them as two distinct stages to give equal importance to product and PSS conceptualization and design. In practice, stages three and four can be either conducted simultaneously or in any order deemed appropriate by the design team. The product designing and engineering stage is introduced before *Stage 5: System designing and engineering* so that before finalizing on the system design, the designer is fully aware of the product component in the PSS. This stage's two processes are (4.1) designing and engineering the product concept and (4.2) environmental, socio – ethical, and economic assessment. [Table 5.7](#) summarizes the processes in Stage 4: Product designing and engineering, results of using the processes and tools in it, gaps identified and proposed addition.

Table 5.7. Processes in Stage 4: Product designing and engineering, results of using the processes and tools in it, gaps identified and proposed addition.

(* a represents new stage/ process/ tool, introduced in response to the gap identified).

Process	Process & tools in it helped	Results	Gap	Proposed addition
* (4.1) Designing and engineering the product concept	• Design and engineering the product concept	• Detailed product design	-	-

* (4.2) Environmental, socio-ethical, and economic assessment	• Evaluation of the product concept on sustainability improvement	• Environmental sustainability evaluation using the ICS toolkit • Environmental, social, and economic sustainability evaluation using SAC checklist	-	-
--	---	--	---	---

(4.1) Designing and engineering the product concept

I designed the BP with the support of the engineering team at iDE-B. Since the workers and the JE owner harbored tacit and implicit knowledge of manufacturing and assembling 2WT based implements, we adopted a participatory design approach while prototyping the design at JE ([Table 5.1](#), point 6). [Figure 5.24](#) shows the first functional prototype, and [Figure 5.2](#) shows the bed planting achieved by the same. [Figure 5.25](#) shows the CAD model of the final design. For details, refer to section [A4.4.1](#).



Figure 5.24. BP prototype for testing the functional aspects of the design.



Figure 5.25. CAD model of the final BP design.

(4.2) Environmental, socio-ethical and economic assessment

The ICS toolkit's *simplified evaluation* was used to qualitatively evaluate the environmental sustainability improvement or worsening of the redesigned product over its life-cycle stages as per the priority set at the beginning of the project ([Figure 5.27](#)). The SAC checklist helped in the sustainability performance evaluation of all three dimensions for BP's agronomic impact as per the priority set at the beginning of the project ([Figure 5.23](#)). For details, refer to section [A4.4.2](#).

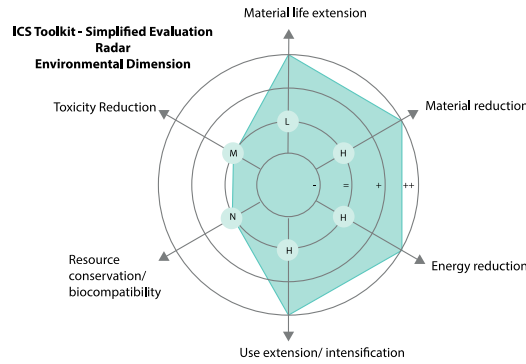

Figure 5.26. ICS Toolkit - simplified evaluation: Radar diagram for environmental dimension

The new *Stage 4: Product designing and engineering*, thus, can be summarized as in [Figure 5.18](#).

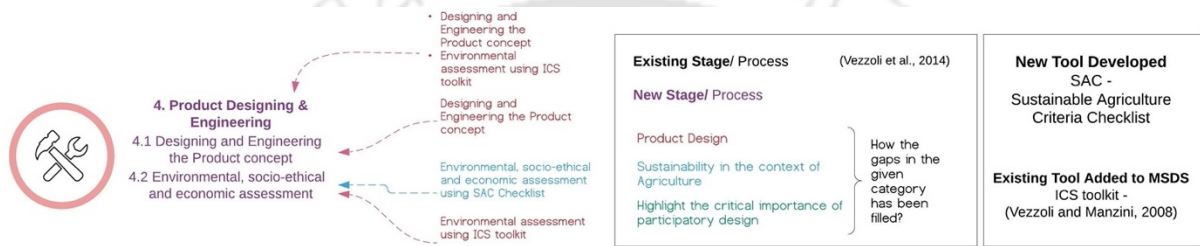

Figure 5.27. The new Stage 4: Product designing and engineering.

5.2.2.6. Stage 5: System designing and engineering

Herein the PSS selected at the end of stage three is detailed and engineered to take it up for implementation. Stage 5 consists of two processes, (5.1) *system design* and (5.2) *environmental, socio-ethical, and economic assessment*. [Table 5.8](#) summarizes the processes in *Stage 5: System designing and engineering*, results of using the processes and tools in it, gaps identified and proposed addition.

Table 5.8. Processes in Stage 5: System designing and engineering, results of using the processes and tools in it, gaps identified and proposed addition.

(* a represents new stage/ process/ tool, introduced in response to the gap identified).

Process	Process & tools in it helped	Results	Gap	Proposed addition
(5.1) System design	<ul style="list-style-type: none"> Map interactions between primary and secondary actors in the new system Define the material, labor, information, and money flows in the system Define the functions, products, services, roles, contributions, and motivations of each actor in the system 	<ul style="list-style-type: none"> Detailed system design 	-	-
(5.2) Environmental, socio-ethical, and economic assessment	<ul style="list-style-type: none"> Describe the improvements Qualitative assessment on three dimensions of sustainability for improvement or worsening 		Sustainability in the agricultural context	*SAC checklist aided assessment
(5.2) + *SAC checklist aided assessment	<ul style="list-style-type: none"> Visualization of the assessment on radar diagrams 			

(5.1) System design

Of all the competing PSS concepts generated in (3.2), the most promising concept was selected post sustainability assessment in (3.3). We further detailed the selected PSS concept in this process (5.1). Thus, we outlined the redesigned system's offering ([Figure 5.21](#)) and actor interactions. Both the primary and secondary actors' interactions were mapped. After that, the system's energy flows were defined by mapping the material, information, labor performance, and money flows ([Figure 5.20](#)). Lastly, we described each actor's functions, products, services, roles, contributions, and motivations. For details, refer to section [A4.5.1](#).

(5.2) Environmental, socio-ethical and economic assessment

"SDO toolkit - checklist concept" was then used to qualitatively assess the expected sustainability improvements on all three dimensions due to the system's implementation. We visualized the expected sustainability improvements alongside the priorities set at the start of the project using radar diagrams for each dimension ([Figure 5.23](#)). For details, refer to section [A4.5.2](#).

Addition to (5.2): SAC checklist-aided assessment (Proposed addition to fill the gap sustainability in the agricultural context)

Since the SDO toolkit cannot assess the sustainability impact of the PSS on the agricultural context, we suggest incorporating a qualitative assessment using the SAC checklist in (5.2) ([Figure 5.23](#)). That will aid in the sustainability assessment and plotting of a radar diagram for sustainability in the agricultural context. The radar diagrams resulting from the SDO, ICS, and SAC aided assessments presented a qualitative and holistic view of the sustainability improvement or worsening of the redesigned PSS on

- ◆ all three dimensions of sustainability
- ◆ on all three levels – product, PSS, and the agricultural context
- ◆ over the entire life cycle of the PSS

While this is indeed a useful comparison toolkit at the design process's fuzzy front-end, the critical weakness is its qualitative-ness. If resources permit, a quantitative assessment at this stage using LCA tools can quantify the actual environmental performance improvement. In this case study, we did not perform this step due to resource constraints and inadequate LCA data.

The redesigned *Stage 5: System designing and engineering* can be summarized as in [Figure 5.18](#).

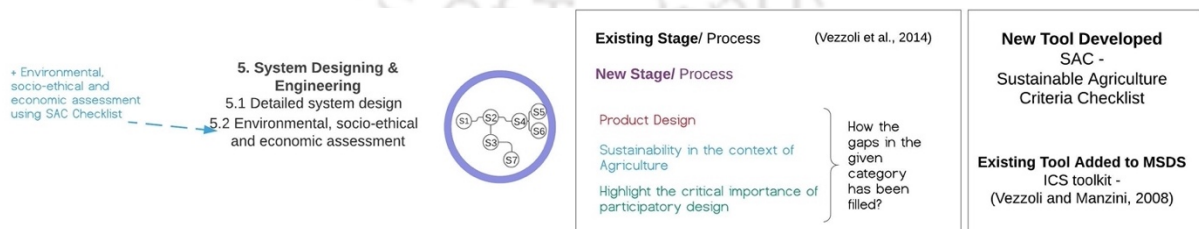

Figure 5.28. Redesigned Stage 5: System designing and engineering.

5.3. Conclusion

The MSDS methodology and ICS toolkit together are helpful in sustainability-oriented design of SAM's product and PSS components. The ICS and SDO toolkit aided analysis on the environmental dimension overlap. The results obtained from the ICS toolkit were a subset of the ones obtained from

the SDO toolkit. Hence, in the analysis phase, one can choose to use only the SDO toolkit. For idea generation, the ICS toolkit is more effective in product level ideation while the SDO toolkit for system and service levels. Hence, for idea generation, both toolkits complement each other. However, they do not aid in sustainability-oriented design, considering sustainability concerns in the agricultural context. The introduction of the additional design and assessment processes using the SAC checklist, as described in [Table 5.2](#), [Table 5.5](#), [Table 5.6](#), [Table 5.7](#), and [Table 5.8](#), introduces agricultural sustainability concerns in the base MSDS methodology.

The application of the MSDS methodology to the sustainability-oriented design process of SAM revealed the following pros and cons:

Pros

- ◆ MSDS can help identify system and service level sustainability concerns, prioritization, sustainability-oriented design, and evaluation on all three dimensions.
- ◆ It offers the scope to PSS stakeholders to together brainstorm and set contextually appropriate priorities to each sustainability criteria in the SDO toolkit. Participatory design is an integral part of MSDS processes and tools. In SAM, the stakeholders come with wide diversity in expertise, knowledge typology, and literacy. As a result, participatory design strategies to bring in communication synergy are of utmost importance.
- ◆ The tool, polarity diagrams, is very useful in identifying and studying competing criteria and sub-criteria within the sustainability verticals and, after that, in making informed decisions on the trade-offs that one will have to make.
- ◆ Due to the PSS focus, MSDS helps in designing the AM along with its entire value chain. Thus, the result is a desirable product and service combination, which together fulfills a unit of satisfaction with an appropriate business strategy to place it in the market.
- ◆ It also offers the flexibility to incorporate other tools into the framework.
- ◆ Being a qualitative assessment-based methodology, it is useful at the fuzzy front-end of the design process, where data availability is low. It is also useful for the design of SAM for small holdings of developing countries where humans, data, and monetary resources for quantitative analysis might be scarce or unaffordable.

Cons

- ◆ For the product level, it is useful only to a certain extent. For example, in "*orient the concept*," the focus is only on system and service level ideation. Accordingly, processes and tools to fill this gap are required, as in the context of SAM, the product is of equal importance.
- ◆ It does not cater specifically to the agricultural domain and requires this orientation for SAM design.
- ◆ As MSDS needs much time and a multidisciplinary workforce, it is a comprehensive but resource-intensive design methodology. However, any system design methodology is resource-intensive due to the width and depth of exploration that it demands.
- ◆ The current visualization of the outcome from each stage and process of the methodology is less user-friendly and can be further enhanced.
- ◆ Being a qualitative assessment-based methodology, the judgment's accuracy depends heavily on the stakeholders' experience and knowledge.

The application of the ICS toolkit for the sustainability-oriented design process of SAM revealed the following pros and cons:

Pros

- ♦ It is a life cycle design-based analysis, design, and assessment toolkit capable of providing comprehensive support for the design of SAM's product level (AM) for environmental sustainability.
- ♦ Being a qualitative assessment-based methodology, it is useful at the fuzzy front-end of the design process, where data availability is low. It is also useful for the design of SAM for small holdings of developing countries where humans, data, and monetary resources for quantitative analysis might be scarce or unaffordable.

Cons

- ♦ It is a qualitative assessment tool, and the accuracy of the judgment depends heavily on the stakeholders' experience and knowledge.
- ♦ It does not cater to the social and economic sustainability vertical.

Considering the above-mentioned pros and cons of the existing sustainability-oriented design supports, a possible sustainability-oriented design approach for SAM's design for small farms of developing countries is outlined in the next chapter.

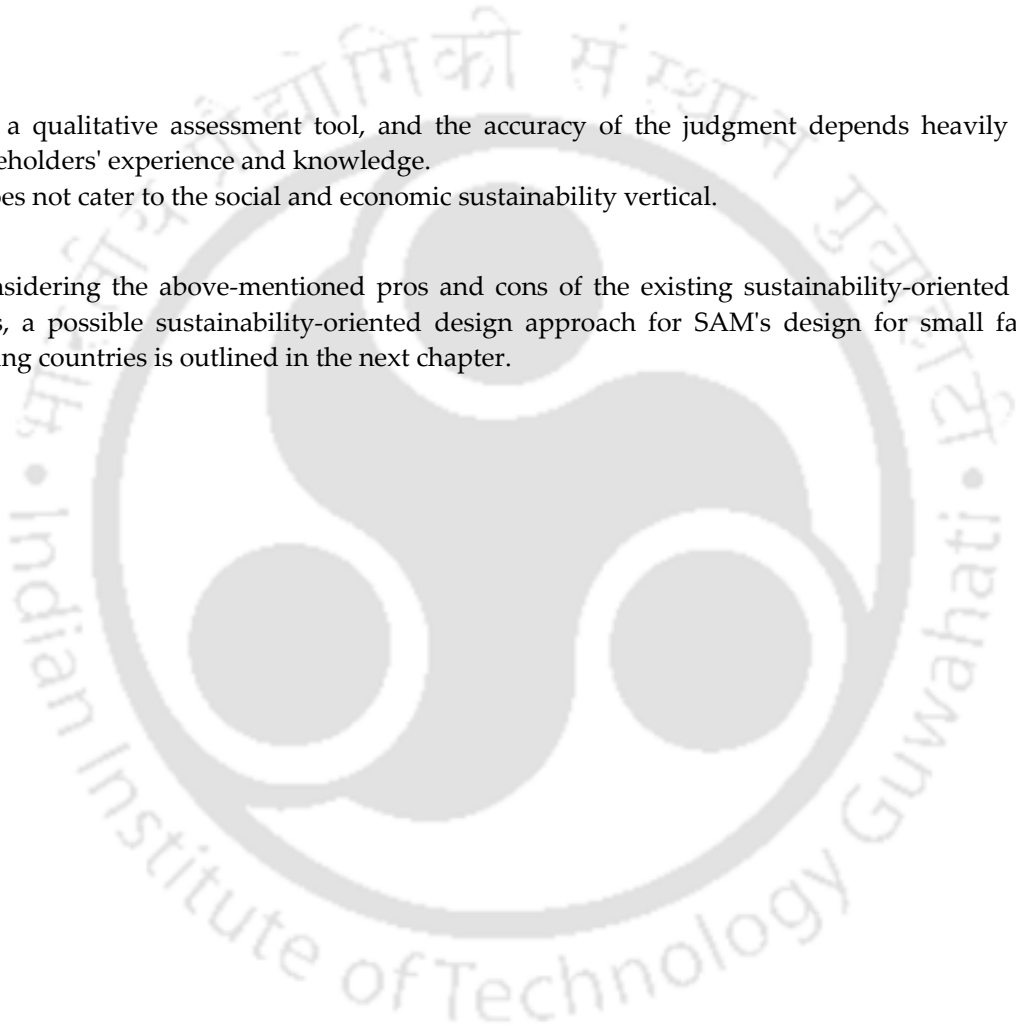

6. D-SAM, a sustainability-oriented design methodology for agricultural machinery and its associated service ecosystem design

This chapter answers research question 2, which enquires:

What could be a possible sustainability-oriented design approach for the design of SAM for small farms of developing countries that take into account:

- ♦ The pros and cons of the existing sustainability-oriented design approaches from related domains; and
- ♦ Addresses a holistic picture of sustainability, including its three dimensions (social, economic, and environmental), in the given context?

The first conceptual framework for the sustainability-oriented design approach was developed with the MSDS methodology as the base. It was formulated while applying MSDS and ICS toolkit to the case study, as discussed in [Chapter 5](#). This framework is then revised to develop the second framework. The key contribution of the revision is the development of the SAM guidelines (G-SAM). G-SAM helps to view sustainability-oriented design of AM from three perspectives using a comprehensive set of guidelines. It merges the SDO and ICS toolkit, and SAC checklist characteristics. The three perspectives are:

- ♦ Perspective 1: S.PSS design - Here, the focus is on designing integrated combinations of products and services that meet a unit of satisfaction for the customers. It maps the entire consumption and production value chain and achieves sustainability across all three dimensions: social, economic, and environmental.
- ♦ Perspective 2: Design for a sustainable agricultural outcome - Here, the focus is on having a sustainable outcome on the agricultural ecosystem, value chain, and stakeholders.
- ♦ Perspective 3: Environmentally sustainable product design - Here, the focus is on developing products with better environmental performance than existing solutions.

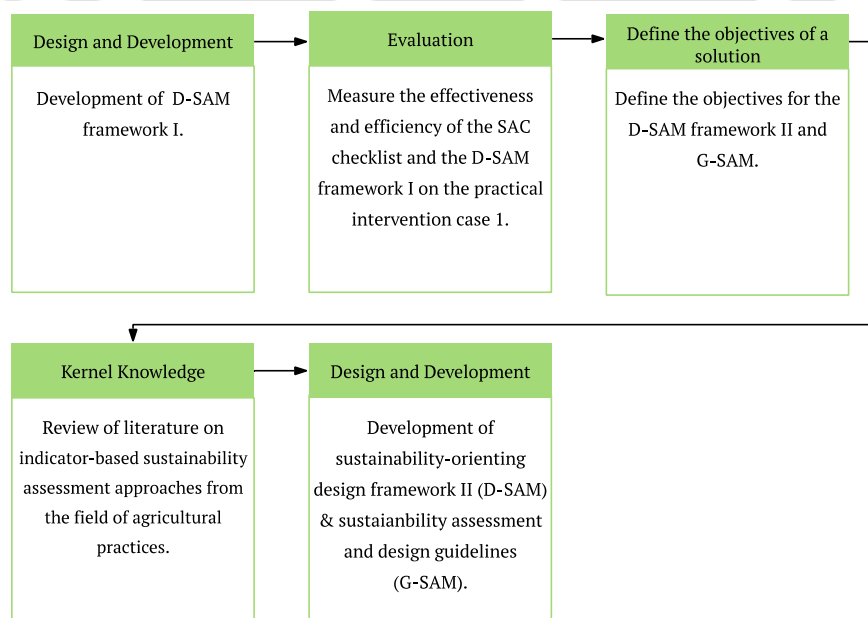

The D-SAM framework I for sustainability-oriented design of SAM is published in ([Banerjee and Punekar, 2020](#)).

6.1. D-SAM Framework I

Considering the pros and cons of the existing sustainability-oriented design supports, a possible sustainability-oriented design approach for SAM's design for small farms of developing countries is outlined in [Table 6.1](#). The framework consists of the MSDS methodology, which aids in system and service design for S.PSS, as the base. The ICS toolkit and the product design modules incorporated in it bring forth the framework's product design focus. The SAC checklist aids in analysis and design for the sustainable agronomic outcome. A participatory design approach is critical to the success of SAM and involves highly educated stakeholders on one hand and illiterate or semi-literate stakeholders on the other. Thus, creating appropriate bridging and communication strategies are required. In this thesis, we have not focused on the development of participatory design strategies. Hence, the sustainability-oriented design framework developed stresses the use of participatory design but does not present a strategy. The participatory design strategies discussed in [Chapter 5](#), [Table 5.1](#), can be used along with other methods like observational research and FGD, as illustrated in the table, for executing the various processes and sub-processes of D-SAM framework I.

6.1.1. D-SAM framework I

[Figure 6.1](#) summarizes D-SAM framework I for sustainability-oriented design of SAM, and [Table 6.1](#) presents the details of its stages, processes, sub-processes, and tools along with the results of using each (sub-)process and tool.

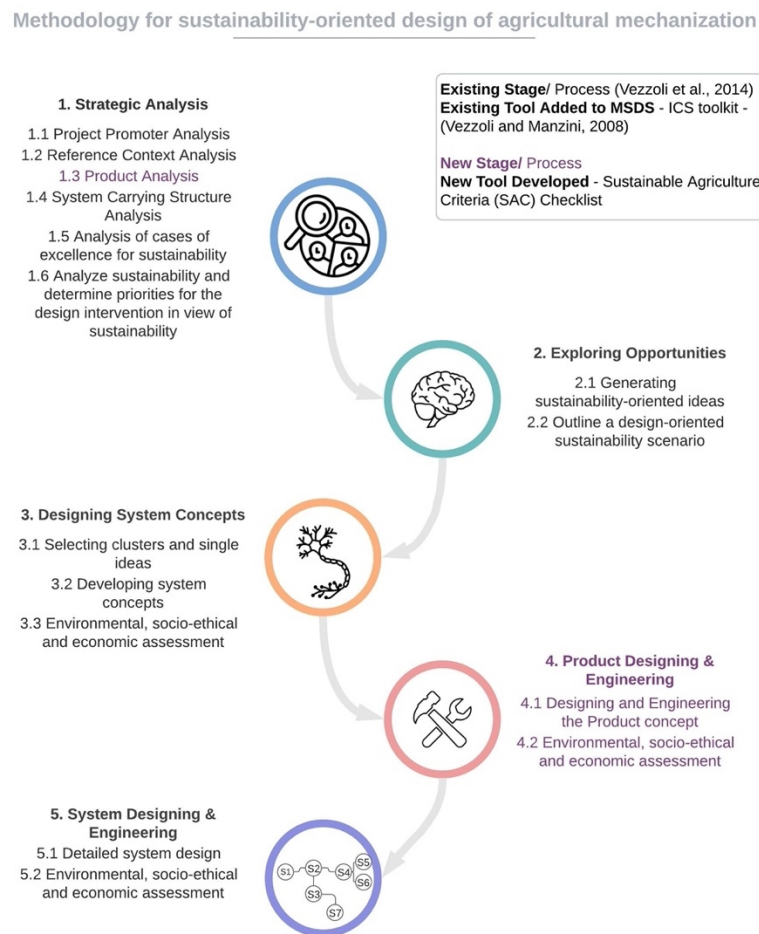

Figure 6.1. D-SAM framework I for a sustainability-oriented design methodology of agricultural mechanization

Table 6.1. A conceptual framework for a sustainability-oriented design methodology of agricultural mechanization.

Note: * from MSDS; **bold** are proposed modifications. Adapted from (Banerjee and Punekar, 2020).

Stage	Process	Sub-process	Result and (tools)
*1. Strategic Analysis	*(1.1) Project promoter analysis and definition of intervention context	*Design intervention's scope description	*Document detailing intervention scope and design brief
		*Analyze project promoter(s)	*Summary of project promoter analysis: mission, primary expertise, (SWOT), and value chain (System Map) analysis
		*Analyze the production and consumption system for the intended design intervention	Analysis of system actors & their interactions (System Map) and mapping the system's technology, culture, and regulatory dynamics
		*Competitor analysis	*Identification of competitors, their offers, market segmentation, and competitive position for the proposed offering (Model 5 Porter Forces)
	(1.3) Product Analysis	*Client or end-user analysis	*Expressed and latent needs analysis (Means-end analysis)
		Identify and analyze existing products/ solutions	Summary of existing products/ solutions, engineering, and manufacturing requirements and shortcomings
		Analyze environmental impact	Analysis of existing products' environmental performance (ICS toolkit) (optional)
	*(1.4) System carrying structure analysis	Define the product design priorities	Product design priorities for the environmental dimension of sustainability (optional)
		*Analyze macro-trends	*Report on social, economic, and technological macro-trends and their influence on the reference context
	*(1.5) Analysis of cases of excellence for sustainability	*Identify and analyze cases of excellence	*Summary of cases of excellence analysis, describing: <ul style="list-style-type: none"> • Offer composition and interaction with the user (Interaction Map) • Actors who produce and deliver the offer (System Map) • Sustainability characteristics (SDO toolkit and SAC checklist)
		*Analyze existing context for environmental, socio-ethical, and economic sustainability	*Analysis of sustainability performance of existing context conducted through (participatory design workshops) using (SDO toolkit and SAC checklist)
	*(1.6) Analyze sustainability and determine priorities for the design intervention concerning sustainability	*Define design priorities	*Design priorities for each dimension of sustainability through (participatory design workshops) using (SDO toolkit and SAC checklist)
*2. Exploring Opportunities	*(2.1) Generating sustainability-oriented ideas	*Define satisfaction unit	*Document detailing the satisfaction unit and sub-satisfactions, set using (participatory design workshops)
		*Generate sustainable product, service, and system ideas	*Environmental, socio-ethical, and economic sustainability-oriented ideas using (SDO and ICS toolkit, and SAC checklist)
	*(2.2) Outline a design-oriented sustainability scenario	*Define clusters and single ideas	*Description of idea clusters and single ideas.
		*Identify polarizing ideas and plot polarity diagrams	*(Polarity diagram) with polarized ideas, visions, and clusters of ideas.

		* Define visions	*(Audiovisual documents) visualizing concepts using (participatory design workshops)	
*3. Designing System Concept	*(3.1) Selecting clusters and single ideas	*Select the most promising ideas and clusters	* Document explaining the selection of ideas and idea clusters, considering (economic and technological feasibility, and user-acceptability) through (participatory design Workshops) . (Polarities diagrams, portfolio diagrams, and Go/ no go evaluation).	
		*Define actor interactions in the new system	*Map of actors in the new system and the material, information, labor, and money flows amongst them (System Map)	
			* Define the product and service offerings	*Summary of the main functions delivered to the user using (offering diagrams)
	*(3.2) Developing system concepts	*Narrate user interactions with the system and other actors for providing the offer		*Summary of the sequence of actor interactions involved in the production and delivery of the offer using (interaction table and interaction storyboard)
			*Assess the environmental, socio-ethical, and economic improvement potential of the concepts	*Description and assessment of the improvement potential for every criterion of each dimension using (SDO toolkit and SAC checklist)
		*Visualize the environmental, socio-ethical, and economic improvements	<ul style="list-style-type: none"> *Environmental, socio-ethical, economic sustainability improvements using (radar diagrams) plotted with data from (SDO toolkit and SAC checklist) *Visualization of the interactions that support sustainability improvements 	
*3.3) Environmental, socio-ethical and economic assessment	(4.1) Designing & Engineering the Product concept		Detailed product design with manufacturing drawings and bill of materials	
	(4.2) Environmental, socio-ethical, and economic assessment	Assess and visualize the environmental, socio-ethical, and economic improvement potential of the product	Assessment through (participatory design workshops) using (ICS toolkit and SAC checklist) and plotting the (radar diagrams)	
*5. System Designing and Engineering	*(5.1) Detailed system design	*Detail the interactions between primary and secondary actors in the new system	*Detailed map of the principal and secondary actors and the material, information, labor, and money flows between them (system map)	
		*Detail the products and services of the offering	*List of primary and secondary functions delivered to users (offering diagrams)	
		*Detail the actor interactions during delivery of the offer	*Narration of sequence of interactions during the production and delivery of the offer (interaction table and interaction storyboard)	
		*Detail actors' role, contribution, and motivations	*(Motivation matrix) showing each actor's contribution to the partnership, their expected benefits, and potential conflicts	
		*Detail the material and non-material elements required for delivery of the offer (and defining who will design/ produce/ deliver it	*Map indicating the elements required by the system and the role of the actors in designing, producing, and delivering it (Solution element brief)	

	(5.2) Environmental, socio-ethical, and economic assessment	*Describe the expected environmental, socio- ethical, and economic improvements due to the proposed system's implementation	*Description and assessment of sustainability improvement potential using (SDO toolkit and SAC checklist)
		Visualize the expected environmental, socio- ethical, and economic improvements	<ul style="list-style-type: none"> • *Plotting (radar diagrams) to represent the improvements (using SDO and SAC checklist) • *Visualizations of interactions that produce the improvements.

6.1.2. Effectiveness of the framework

The key learning from the development and application of D-SAM framework I on the case study described in Chapter 5 are:

1. Design of an AM-based S.PSS should be viewed from three perspectives: 1. S.PSS design; 2. Design for a sustainable agricultural outcome; and 3. Environmentally sustainable product design. In S.PSS design, the focus is integrated development of products and services that jointly fulfill a 'unit of satisfaction' for the customers. It maps the entire consumption and production value chain and helps in achieving sustainability across all three dimensions. For sustainable agricultural outcomes, the emphasis is on achieving a sustainable agricultural value chain considering all three sustainability dimensions. The environmentally sustainable product design perspective focuses on developing product solutions for better environmental performance than the ones available in the current scenario.

2. Design supports for perspective 1 are described in section 4.3. For perspective 3, the design supports are elaborated in section 4.2. However, for perspective 2, no tools from the AM domain are available, as illustrated through literature research in section 4.5. The SAC checklist designed and reported in section 5.2.2.2, is a preliminary tool and can be further refined to support the designer. SAC, in its current form, is suitable for assessment. It needs further development to aid in the ideation process. Development of an ideation aid will be constructive as AM based S.PSS design requires the cross-pollination of disciplinary knowledge from multiple domains. In the absence of such aid, the design process's time and resource requirement will be considerably high. It can also be a daunting task for less experienced designers (discussed in Chapter 7).

3. MSDS, like any other PSS design methodology, is exhaustive in terms of human resources and time requirements. The conceptual framework I add further steps and tools into it. Thus, design support that binds together all the three perspectives into one will be friendlier for a designer and consume less time.

4. The task of sustainability-oriented design of AM-based S.PSS can be achieved using the five stages elaborated in D-SAM framework I: *Strategic analysis; Exploring opportunities; Designing system concepts; Product designing and engineering; System designing, and engineering*. However, it has been observed that designers usually tend to analyze and ideate hand in hand. Also, while performing the analysis and ideation separately, it was observed that one had to time and again go back to the analysis to refresh memory while doing the ideation. Many designers need to note down their ideas in a separate notebook to come back to them during the ideation phase. Thus, combining the strategic analysis and exploring opportunities steps can aid in synchronized work.

Thus, an iteration of D-SAM framework I was initiated. The iteration's central aim was to formulate design support that combines the three perspectives and aids in assessment and design. Since no design support specifically for AM context is available, a literature review was conducted to identify indicator-based sustainability assessment approaches from various agricultural practices. These could be used to identify the indicators for AM context with appropriate contextualization. Nineteen indicator-based sustainability assessment methods from agriculture, published in English language peer-reviewed journals, were identified. They cater to all three dimensions of sustainability. They were developed for various geographies, different agricultural practices, and various stakeholders' use. [Appendix 5](#), presents a comparative study of these methods. The adapted indicators from these methods and the SDO and ICS toolkit and SAC checklist formed G-SAM's assessment and design base. G-SAM also combines the two stages of MSDS, *Stage 1: Strategic analysis (Process 1.6 - Analyze sustainability and determine priorities for the design intervention concerning sustainability)* and *Stage 2: Exploring opportunities (Process 2.1 - Generating sustainability-oriented ideas)*.

6.2. Refining D-SAM Framework I and development of G-SAM

This section presents the development process of G-SAM.

6.2.1. Literature research - Sustainability assessment methods and tools for agricultural systems

A DfS support should consist of two main components: the sustainability assessment component and the design component. The two components can then be iteratively used to conduct DfS. Several researchers and agencies working in sustainable agricultural practices have proposed various sustainability assessment tools that cater to different target groups, needs, and goals. There are no tools that aid in the design process. The assessment tools are categorized into monetary, biophysical, or indicator-based tool families. The concept of *willingness to pay* or *willingness to accept* forms the basis for the monetary calculations-based tools ([Gasparatos et al., 2008](#)). Thus, it gives sustainable development a very anthropocentric view. It relies heavily on the assumption that complete information is available on the system's operation and interrelations under investigation. (ibid). It has been rejected on ethical grounds by Heinzerling and Ackerman ([2002](#)). The shortcomings and limitations of this approach led to the formulation of biophysical metrics and tools. The techniques in this category operate at three scales: emergy, exergy, and the ecological footprint. A large number of case studies have used these three techniques. These metrics offer the ability to quantify environmental and economic sustainability issues but are mostly unable to tackle the social dimension. Thus, sustainability indicators and composite indices come into the landscape. ([Gasparatos, 2010](#); [Gasparatos et al., 2008](#)). These have become central to the Sustainable Development debate since it:

"...can provide crucial guidance for decision-making in a variety of ways. They can translate physical and social science knowledge into manageable units of information that can facilitate the decision-making process. They can help to measure and calibrate progress towards Sustainable Development goals. They can provide an early warning, sounding the alarm in time to prevent economic, social and environmental damage. They are also important tools to communicate ideas, thoughts and values because as one authority said, We measure what we value, and value what we measure." ([United Nations, 2001](#)).

To develop G-SAM, we identified the following ([Table 6.2](#)) nineteen indicator-based sustainability assessment methods from literature published in English language peer-reviewed journals. [Appendix 5](#) presents the approach, aim, target group, definition of sustainable agriculture, assessment level and procedure, and goal setting methodology for them.

Table 6.2. Indicator-based sustainability assessment methods from agriculture

SN	Name of indicator-based sustainability assessment method	Reference
1	AVIBIO - AViculture BIologique	(Pottiez et al., 2012)
2	COSA - Committee on Sustainability Assessment	(COSA, 2013 ; Giovannucci et al., 2008)
3	Development and evaluation of an on-demand sustainability tool in Flanders	(Coteur et al., 2014)
4	A methodological approach to assess and compare the sustainability level of agricultural plant production systems	(Dantsis et al., 2010)
5	DSI - Dairyman Sustainability Index	(Elsaesser et al., 2015)
6	FARMSMART	(Tziliyakis and Lewis, 2004)
7	FESLM - Framework for the Evaluation of Sustainable Land Management	(Smyth et al., 1993)
8	IDEA - Indicateurs de Durabilité des Exploitations Agricoles	(Zahm et al., 2008)
9	ISAP - Indicator of Sustainable Agricultural Practice	(Rigby et al., 2001)
10	KSNL - Criteria for sustainable farming	(Ehrmann and Kleinhanß, 2008)
11	MESMIS - Framework for Assessing the Sustainability of Natural Resource Management	(López-Ridaura, 2002)
12	MMF - Multiscale Methodological Framework	(Keulen et al., 2005)
13	MOTIFS - Monitoring Tool for Integrated Farm Sustainability	(Meul et al., 2008)
14	PG - Public Goods Tool	(Gerrard et al., 2012)
15	RISE - Response Inducing Sustainability Evaluation	(Grenz, 2011 ; Grenz and Sereke, 2017 ; Grenz et al., 2009)
16	SAFA - Sustainability Assessment of Food and Agriculture Systems	(FAO, 2013b)
17	SAFE - Sustainability Assessment of Farming and the Environment	(Van Cauwenbergh et al., 2007)
18	SSP - Sustainability Solution Space for Decision Making	(Binder and Wiek, 2007 ; Binder et al., 2012 ; Wiek and Binder, 2005)
19	Development and application of a multi-attribute sustainability function for Dutch dairy farming systems	(Van Calker et al., 2006)

The key insights from the study are as follows:

1. The key strength of the integrated indicator-based sustainability assessment tools is that it helps achieve the broader goal of integrating the three sustainability dimensions. These indicator-based sustainability assessment tools are generally structured following three or four hierarchical levels. For example, [de Olde, E.M. et al. \(2016\)](#) used the hierarchy as *Dimension; Theme; Sub-theme; Indicator*. Nonetheless, researchers have used various terminology to depict each of these levels, as illustrated in [Figure 6.2](#). In the thesis, the hierarchy used is: Dimension, Criterion, Impact Category (further elaborated using Critical Features and Diagnostic Criteria), and Indicators (elaborated in section [6.2.7](#)).
2. Indicator-based sustainability assessment tools in agriculture can be distinguished based on:
 - a. Spatial level (for example, farm level, region level).
 - b. Degree of stakeholder participation – like top-down farm assessment methods, top-down regional assessment with some stakeholder participation, and bottom-up, trans-disciplinary methods with stakeholder participation throughout the process
 - c. Assessment approach – like self-assessment, interview by an advisor, questionnaire, external auditors.
 - d. Purpose – like research, farm advice, certification, self-assessment, consumer information, policy, and planning.
 - e. Target users – like farmers, advisors, researchers, policymakers, consumers. ([Schader et al., 2014](#)).

Terminology in the thesis	Example from thesis	Other Terminology
Dimension	Economic	Aspect (van Calker et al., 2007) Domain (Bausch et al., 2014) Pillar (van Cauwenbergh et al., 2007)
Criterion	Market Position and Competitiveness	Component (Bélanger et al., 2012) Issue (de Boer and Cornelissen, 2002) Attribute (van Calker et al., 2007) Principle (van Cauwenbergh et al., 2007) Impact Category (Haas et al., 2000) Criterion (van Cauwenbergh et al., 2007) Theme & Sub-theme (FAO, 2013)
Impact Category -> Critical Feature -> Diagnostic Criteria	System Level -> Market Position and Competitiveness -> Strength of the market position and competitiveness at the system level	
Indicator	Example - Does the PSS have a marketing strategy articulating the customers and how to reach them?	Parameter (Guerci et al., 2013)

Figure 6.2. The terminology used in the thesis for the hierarchical levels for sustainability assessment and those used by other researchers (adapted from (de Olde, E.M. et al., 2016)). (Bausch et al., 2014; Bélanger et al., 2012; de Boer and Cornelissen, 2002; Guerci et al., 2013; Haas et al., 2000; van Calker et al., 2007)

- To achieve an integrated approach to agricultural sustainability assessment, the bottom-up, integrated participatory, or transdisciplinary methods are more appropriate (Binder and Wiek, 2007).
- Indicator-based sustainability assessment tools in agriculture can be distinguished based on data requirements as full sustainability assessment (FSA) or rapid sustainability assessment (RSA) (Marchand et al., 2014). RSA tools are more oriented toward communicating and learning. Hence, they are well-suited for large groups, raise awareness, trigger interest in sustainable practices, and highlight good or bad performance areas. RSA tools require less time and money than FSA tools. Since we target the design phase, where the amount of data available is usually low, and comparisons between options need to be done faster, RSA is more suitable. FSA can be developed and used at a later phase of design when more information about the system is available.
- These sustainability assessment tools show a large degree of variance in their starting point, objective, and assumptions like what is important to be measured, how and which sustainability perspectives are relevant and legitimate. Thus, the question arises on how to design or select a particular tool.
- There are fewer efforts devoted to developing frameworks for the derivation of indicators sets (CIFOR, 1999; Guijt and Moiseev, 2001; Smyth et al., 1993). One such tool, Sustainability Solution Spaces (SSP), was conceptualized to develop a sustainability assessment tool for city-regions (Wiek and Binder, 2005). It has also been used by various researchers to compare the sustainability of various indicator-based sustainability assessment tools for agricultural domains (Binder et al., 2010; Binder et al., 2012; Castoldi and Bechini, 2010; de Olde, E. et al., 2016; Marchand et al., 2014). It was found useful for assessing Austria's sustainability in collaboration with the Federal Ministry of Agriculture, Forestry, Environment, and Water Management (Hecher, 2011). Thus, its applicability to a wide range of scenarios is proven. SSP aids in formulating a geometric model with relevant indicators for a particular context and map their relations using a combination of top-down and bottom-up approaches (Binder et al., 2010). This aids in better systemic understanding. The SSP is seen as a multi-dimensional volume, where the indicators are the individual dimensions. For a solution to be sustainable, it should lie within the boundaries of this volume. To attain sustainability, one can either change the indicator boundaries or their relations with each other. These changes can be done at the policy, regulation, or market level. Thus, the framework of this tool appears to be very useful for an S.PSS designer as well. Marchand et al. (2014) developed a framework for comparing sustainability assessment tools using the SSP framework (Binder et al., 2010; Wiek and Binder, 2005) and enhanced it by incorporating critical success factors for the implementation of sustainability assessment tools developed by de Mey et al. (2011). G-SAM development used (Marchand et al.)'s framework along with the indicator formulation method from the MESMIS approach (López-Ridaura, 2002), as elaborated in Table 6.3.

7. Of the nineteen indicator-based sustainability assessment methods, the MESMIS approach ([López-Ridaura, 2002](#)) is developed through case studies from Mexico and Latin America, which are also developing countries. Consequently, it serves the thesis with a contextual sustainability framework. The MESMIS approach is a "systemic, participatory, interdisciplinary and flexible framework for evaluating sustainability" in the context of peasant agriculture and peasant Natural Resource Management Systems²⁵. The key take-aways for the SAM sustainability-oriented design approach from MESMIS are:
- It should target balancing short-term oriented economic and agronomic indicators with the long-term oriented economic, social, environmental, and agronomic indicators.
 - It should be adaptable for varying data and resource levels, depending on technical and financial resource availability.
 - It should aid design and assessment through a participatory process by an interdisciplinary team, consisting of all stakeholders, experts, and external evaluators.
 - The indicator formulation process of G-SAM is derived from MESMIS ([Figure 6.3](#)). First, the reference system and its *Critical Features* (CF), i.e., aspects that enhance or constrain the system's attributes are identified. The CF is then used to derive the indicators in a two-step process. First, they are linked to a set of *Diagnostic Criteria* (DC), and these are then connected to a group of indicators that can measure or estimate the DC. G-SAM's indicator formulation process is elaborated in section [6.2.7](#).

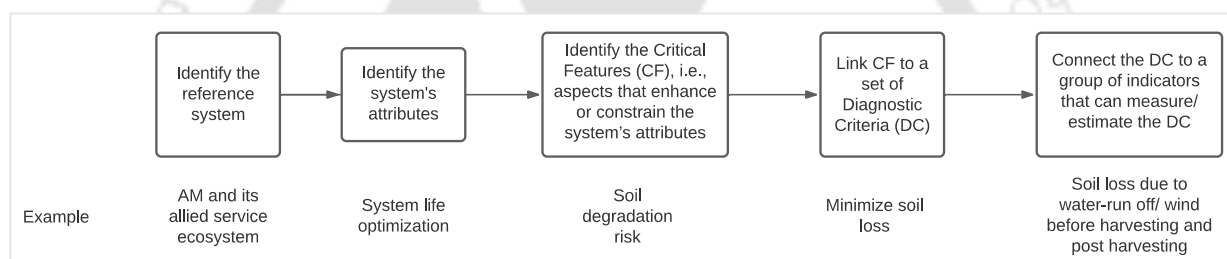

Figure 6.3. G-SAM's indicator formulation process, as derived from MESMIS approach ([López-Ridaura, 2002](#))

8. SAFA is assessment support developed by the [Natural Resources Management and Environment Department and Food and Agriculture Organization of the United Nations \(2012\)](#). It is also suitable to form the base for G-SAM development. In 2012, FAO developed SAFA as a common language guideline consisting of procedures, principles, and minimum requirements for sustainability assessment of food and agricultural value chains for the United Nations Conference on Sustainable Development. SAFA's guiding vision is "environmental integrity, economic resilience, social well-being and good governance." The guidelines are developed as a globally applicable template for assessment, which can also guide the development and application of a sustainability assessment system. It includes a generic set of core sustainability categories, possible performance assessment indicators, and minimum sustainability criteria. Consequently, it sets a frame to which existing systems can be related and on which new assessment methods can be based. The structure of these guidelines are formed by adapting the guidelines from ISO14040:2006 ([International Standard Organization, 2009](#)), the ISEAL Code of Good Practice ([ISEAL Alliance, 2010](#)), the Sustainability Reporting Guidelines, and the Food Sector Supplement of the Global Reporting Initiative ([GRI, 2011a, b](#)) and adapting them to the food and agriculture sectors' supply chain (farm to the retailer). The structure of the category protocols is based upon ([GRI, 2011a, b](#)), the RISE method ([Grenz, 2011](#)) and the description of the German KSNL method ([Breitschuh and Bachmann, 2008](#)). Due to

²⁵ natural ecosystems altered by humans through processes to obtain desired products and services like food, fuel and recreation.

its global applicability and possibility of use in developing sustainability assessment systems, G-SAM uses SAFA's definition of sustainable development in agriculture (section 6.2.4).

This literature research, therefore, formed the backbone for G-SAM's indicator identification process (diagrammatically represented in Figure 6.4). G-SAM is developed using Marchand et al. (2014)'s framework. That framework was developed for comparing sustainability assessment tools using the SSP framework (Binder et al., 2010; Wiek and Binder, 2005) and the critical success factors for the implementation of sustainability assessment tools developed by de Mey et al. (2011). The indicators are formulated using the MESMIS approach development process. I developed the SAM's design support using the strategies from SDO Toolkit – orient the concept and ICS toolkit's eco-ideas board and data from the literature. The strategy here is to provide open-ended ideation cues to guide, educate, and inform a designer during the design process, as Lofthouse (2006) suggested. The G-SAM development process and the guidelines are elaborated in the subsequent sections. The framework used for the development of sustainability-oriented design support is presented in Table 6.3 below.

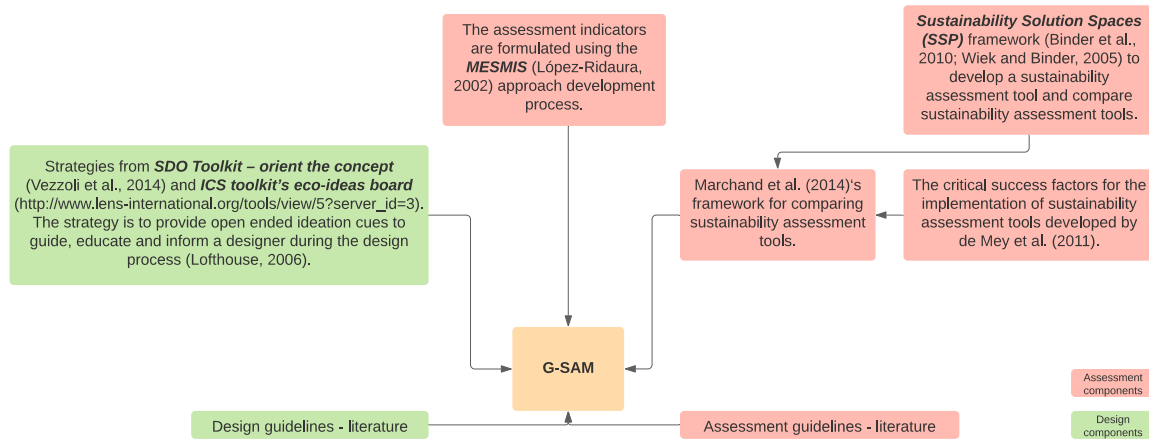

Figure 6.4. Deriving the framework to develop G-SAM.

Table 6.3. Framework to develop G-SAM.

Assessment support development adapted from (Binder et al., 2010; de Mey et al., 2011; López-Ridaura, 2002; Marchand et al., 2014; Wiek and Binder, 2005). (de Mey et al., 2011) marked (#); (López-Ridaura, 2002) marked (-); Design support development - Author (marked +)

Dimension	Phase	Characteristic & Description
Normative dimension	-	Sustainability definition
		Goal setting procedure
		Indicator assessment, weighing and aggregation methods
		Tool function/ purpose #
Systemic dimension	-	Parsimony – support’s simplicity in system representation
		Sufficiency – support’s sufficiency in system representation
		Indicator interaction through the support
Procedural dimension	Preparatory phase	User group identification
		Contextualization
		Stakeholder involvement – procedure for achieving the same
		Scale of assessment
		Reference system identification

Indicator Formulation ~	Critical Factor (aspects that enhance or constrain system's attributes) identification
	Mapping the Critical Factor with the sustainability definition
	Linking the Critical Factor to Diagnostic Criteria
	Indicator identification to measure the Diagnostic Criteria
Phase of indicator selection	Possibility to select indicators
Measurement phase (quantitative/ qualitative)	Data correctness – user's perception #
	Data availability #
	User-friendliness – user's perception of the support #
	Compatibility – with current data systems #
Assessment phase (benchmarking, aggregation, integration)	Tools' Transparency – calculations, weighing, and aggregation #
Design phase +	Ideation cues identification - open-ended ideation cues to guide, educate and inform the designer
	Knowledge correctness – user's perception
	Knowledge availability
	Transdisciplinary knowledge cross-pollination
	User-friendliness – user's perception of the support
Applicability of assessment (#) and design (+) results follow up	Output accuracy – user's perception and to the actual value #
	Complexity – tool's procedures, presentation and interpretation of the results #
	Communication aid – while discussing sustainability #
	Relevance (effectiveness) – user's perception #

6.2.2. Defining the goal

G-SAM aims to provide a set of sustainability-oriented design guidelines which can be used to

1. Analyze the sustainability of an AM based PSS for the small farms of developing countries on the three dimensions of sustainability and throughout its lifecycle.
2. Determine sustainability priorities for design intervention; and
3. Generate sustainability-oriented design ideas.

6.2.3. Defining the target group

G-SAM is designed primarily for the use of designers and AM design engineers. These two groups are mainly involved in the design and development of AM. G-SAM can be used by others as well if the team involves designers or AM design engineers.

6.2.4. Definition of sustainable agricultural development and sustainable agricultural mechanization

G-SAM uses the sustainable agricultural development definition by FAO, which states sustainable agricultural development is *"the management and conservation of the natural resource base, and the orientation of technological and institutional change in such a manner as to ensure the attainment and continued satisfaction of human needs for present and future generations. Such sustainable development (in the agriculture, forestry and fisheries sectors) conserves land, water, plant and animal genetic resources, is environmentally non-degrading, technically appropriate, economically viable and socially acceptable"*. (FAO Council, 1989). SAFA also uses the same definition (FAO, 2013a).

G-SAM uses the sustainable agricultural mechanization definition of FAO, which states *"It eases and reduces hard labour, relieves labour shortages, improves productivity and timeliness of agricultural*

operations, improves the efficient use of resources, enhances market access and contributes to mitigating climate related hazards. Sustainable mechanization considers technological, economic, social, environmental and cultural aspects when contributing to the sustainable development of the food and agricultural sector” (FAO, 2016b).

6.2.5. Defining the assessment level and scale

G-SAM targets PSS level assessment and design and can cater to the product, service, and system levels. It caters to three dimensions of sustainability: environmental, economic, and social. It uses RSA as our target is to conduct the evaluation rapidly and be able to do it even when we have less amount of information. That is mostly the case in small farms of developing countries and at the design process's fuzzy front-end.

6.2.6. Defining the scope

The scope for the developed sustainability-oriented design support can be defined as an AM based PSS design context where all the below-mentioned criteria are applicable:

1. The AM is a complex machine consisting of several sub-assemblies.
2. The AM should have a significant amount of embodied material and energy. It should have a considerable impact on all three dimensions of sustainability.
3. The AM should be expensive for individual ownership and have only sparse utilization in individual ownership. A PSS mode consumption of the AM should offer a high density of usage and make it more cost-effective for consumption.

6.2.7. Determining the rapid sustainability assessment indicators and design guidelines of G-SAM

In the context of agricultural tools, variation in terminology in the hierarchical levels in sustainability assessment exist (key insights from literature research, point 1). For example, SAFA's four dimensions are *good governance, environmental integrity, economic resilience, and social well-being* (FAO, 2013a). For COSA, the dimensions are referred to as *global themes* and are categorized as *social, economic, and environmental* (Committee on Sustainability Assessment). The thesis uses four hierarchy levels (Figure 6.2):

4. *Level 1: Dimension* – The three dimensions, environmental, economic, and social from S.PSS methodology is used.
5. *Level 2: Criterion* – These are system attributes that define the measurement of a dimension. Figure 6.5 below presents an example. As the PSS level assessment is chosen for G-SAM, the criterion grouping, as discussed in the SDO toolkit is used. The criteria for the three dimensions are:
 - a. Environmental
 - i. System Life Optimization
 - ii. Optimization of Resource Management
 - iii. Transportation/ distribution reduction
 - iv. Waste minimization/valorization priority
 - v. Conservation/ biocompatibility
 - vi. Toxicity Reduction
 - b. Economic
 - i. Market Position and Competitiveness
 - ii. Profitability or added value for companies
 - iii. Added value for customers
 - iv. Long term business development/ risk
 - v. Partnership/ co-operation
 - vi. Macro-economic Effect
 - c. Social

- i. Improve employment and working conditions
- ii. Improve equity and justice in relation to stakeholders
- iii. Enable a responsible and sustainable consumption
- iv. Favor/ integrate weaker and marginalized strata
- v. Improve social cohesion
- vi. Empower/ valorize local resources

Dimension		Environmental		
Criterion		1. System Life Optimization		
Impact Category	Critical Features	Diagnostic Criteria	Rapid Assessment Checklist	Design Guidelines
1. System Life Optimization				
Soil	Soil Degradation Risk	Minimize soil loss	Possibility of soil erosion due to water-run off or wind <ul style="list-style-type: none"> • before harvesting • post harvesting Risk of soil loss <ul style="list-style-type: none"> • due to harvesting machinery • during soil preparation phases 	<ul style="list-style-type: none"> • Support operations like mulching, grass cover, inter-row management, and cover crop etc. • Design for measures to conserve soil by improving water use by plants – counter planting, soil cover, live fences, hedgerows, buffer zones, soil berms, etc. • Minimize soil loss due to the harvesting of crops growing underground (like ginger, turmeric, carrots, potatoes, etc.). • Minimize soil loss in the form of soil dust formed due to soil preparation.
		Minimize tillage-related risk	Possibility of <ul style="list-style-type: none"> • the weight of the machinery changing the soil bulk density • producing over compaction of soil • causing mineralization of soil organic matter, reducing aggregate stability • continuous tillage leading to the formation of plough pan beneath the tilled layer • the eventual increase in soil penetration resistance for the roots 	<ul style="list-style-type: none"> • Reduce machinery weight. • Ensure the machinery does not change the soil bulk density. • Combine the soil, weather, crop type, machinery information, soil moisture models and soil compaction models to achieve optimal compaction. • Prevent the mineralization of soil organic matter. <ul style="list-style-type: none"> • Maintain aggregate stability. • Avoid plough pan formation. • Avoid the eventual increase in soil root penetration.
	Soil Fertility Management	Enhance soil fertility	What are the deterrents to natural nutrient cycle management processes?	Enhance natural nutrient management of the soil through processes like intercropping, fallowing, crop rotation.
		Enhance soil organic content	Identify the processes which damage the soil organic content.	Enhance soil organic content.

Figure 6.5. Sample from G-SAM for the environmental dimension.

6. *Level 3: Impact Category* - The impact category (in the example, *soil*) highlights the entity which has an impact on the criterion (*1. System life optimization*). It is further elaborated using *CF* and *DC*.
 - a. *Critical Features* – *CF* consists of vulnerabilities (*soil degradation risk*), problems, and the strongest and most prominent features (*soil fertility management*) of the reference system. The *CF* is used to derive the indicators in a two-step process.
 - b. *Diagnostic Criteria* – First, *CF* are linked to a set of *DC* (*minimize soil loss*). *DC* help to diagnose the *CF*.
7. *Level 4: Rapid Sustainability Assessment Indicators* – The *DC* are then linked to a set of *RSA* indicators (*possibility of soil erosion due to water-run off or wind before harvesting*), which can measure or estimate the *DC*.

The *RSA* indicators and design guidelines are defined using the

- ♦ SAFA guidelines ([FAO, 2013a](#)),
- ♦ GRI G4 sector guidelines for Food Processing Industry ([Global Reporting Initiative, 2014](#)),
- ♦ all other approaches mentioned in [Appendix 5](#),
- ♦ literature research using the keywords: agricul*, machin* and <the category – soil, air, water, energy, biodiversity, waste, climate> ([Appendix 6](#)). [used only for the environmental dimension]
- ♦ the *ICS* and *SDO* toolkit, and
- ♦ the *SAC* checklist.

The indicators from the tools, as mentioned above, were adapted to the context of *AM* based *PSS* considering the short-term and long-term impact. They are presented in:

- ♦ [Table 6.5. G-SAM – Environmental Dimension](#),
- ♦ [Table 6.6. G-SAM – Economic Dimension](#), and
- ♦ [Table 6.7. G-SAM – Social Dimension](#).

Task flow for the environmental dimension

The task flow (Figure 6.6) for deriving the environmental dimension's RSA indicators and design guidelines are as follows:

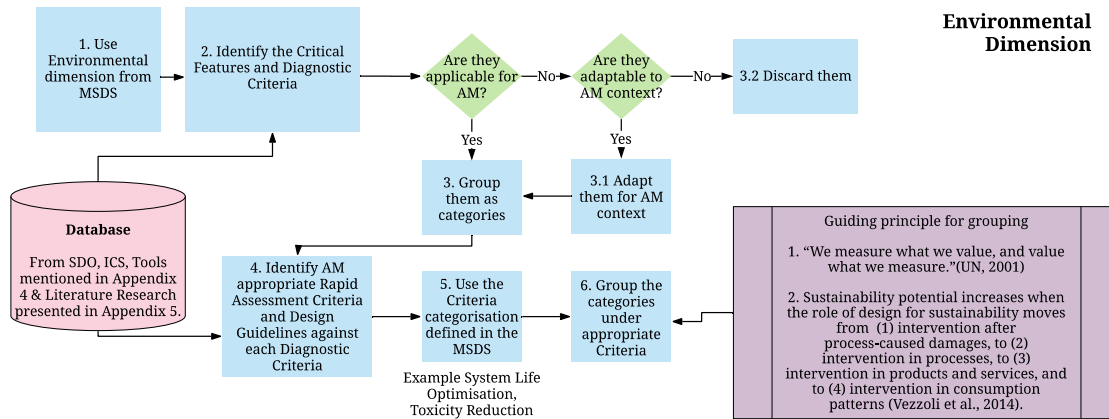

Figure 6.6. Task flow for deriving the environmental dimension of G-SAM.

Step 1: The CF and DC are identified using the list of sources mentioned above in bullet points.

Step 2: If those identified pointers were not directly applicable to the AM based PSS context, they were adapted.

Step 3: These were then grouped into the impact categories.

Step 4: The RSA indicators and design guidelines were drawn from the bulleted lists mentioned at the beginning of this section.

Step 5: These were then grouped under appropriate criterion heads. The CF and DC drawn up from the literature were fitted into one of the MSDS criterion groupings. While grouping the indicators for the environmental dimension, two guiding principles were considered:

- ♦ The indicator-based assessment has become central to the Sustainable Development debate since it: "...can provide crucial guidance for decision-making in a variety of ways. They can translate physical and social science knowledge into manageable units of information that can facilitate the decision-making process. They can help to measure and calibrate progress towards Sustainable Development goals. They can provide an early warning, sounding the alarm in time to prevent economic, social and environmental damage. They are also important tools to communicate ideas, thoughts and values because as one authority said, "We measure what we value, and value what we measure." (UN, 2001) Taking this guiding principle, we grouped the CF and DC. For example, the DC *optimization of residue management practice* can be looked at criterion level 2. *Optimization of Resource Management*, or 4. *Waste minimization/valorization priority*. When we measure it as a resource, we value it as a resource and not waste. Thus, the DC *optimization of residue management practice* is placed under criterion level 2. *Optimization of Resource Management*.
- ♦ The second guiding principle is the fact that the role of design for sustainability can be viewed as (1) intervention after process-caused damages, (2) intervention in processes, (3) intervention in products and services, and (4) intervention in consumption patterns (Vezzoli et al., 2014). When intervention is done at the consumption pattern level, we can avoid the possibility of causing damages from the very onset. The sustainability potential is highest at level 4 and reduces

subsequently from level 3 to 1 (section 4.1). Hence, a CF or DC, if it could be placed in any of these four design strategy levels, it was placed at the highest level possible. For example, *minimize soil loss* can be seen as important for 1. *System life optimization*, as well as 2. *Optimization of resource management* and 5. *Conservation/ biocompatibility*. By looking at *minimize soil loss* at 1. *System life optimization* level we can achieve intervention in consumption patterns and thereby avoid causing pollution.

Task flow for the economic and social dimension

The task flow (Figure 6.7) for deriving the economic and social dimension's RSA indicators and design guidelines are as follows:

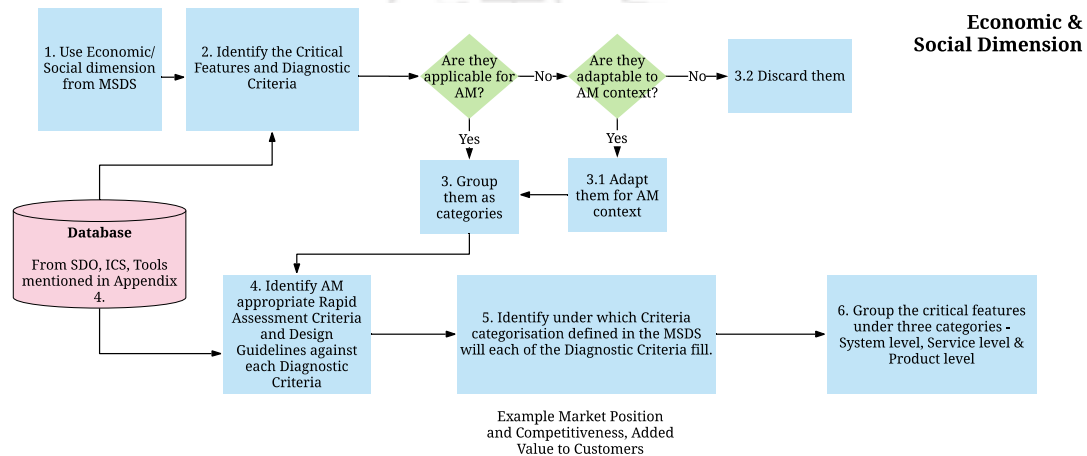

Figure 6.7. Task flow for deriving the economic and social dimension of SAM.

Step 1: The CF and DC were identified from the bulleted sources mentioned above. The guidelines of SAFA (FAO, 2013b) and COSA (COSA, 2013) were particularly useful since they are developed from an agricultural enterprise perspective. Figure 6.8 below shows a sample of the initial CF, (sub-)DC, and RSA indicators drawn and grouped into categories (Appendix 7 shows the full list).

Step 2: These were adapted to AM based PSS context if not directly applicable.

Step 3: These were then grouped into categories. As shown in the example, for the category *PSS providers' investment*, both *internal* and *community investment* (CF), are essential for the PSS's sustainability. The DC for *internal investment* is *measuring and improving the impact of the internal investment on the providers' social, economic, environmental, governance, and long-term profitability*. The DC for *community investment* is measured in terms of *impact on the community*.

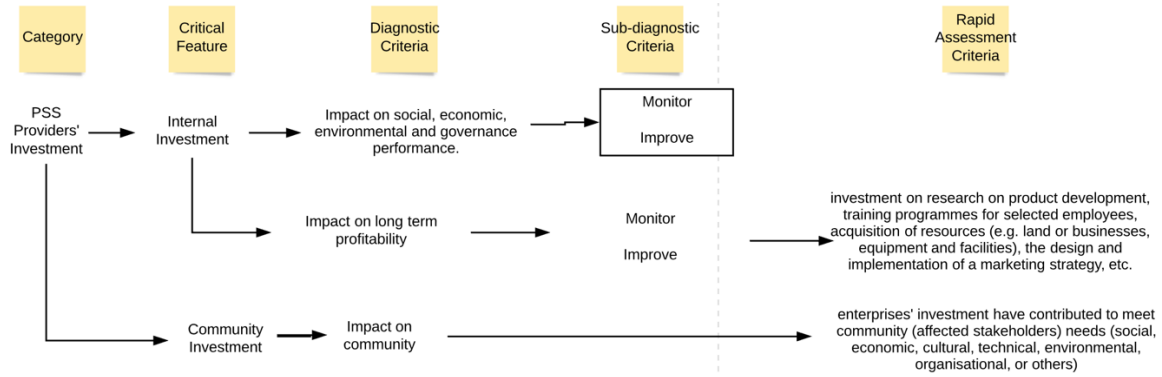

Figure 6.8. A sample of the initial critical features, diagnostic and sub-diagnostic criteria, and RSA indicators drawn and grouped into categories.

Step 4: The RSA indicators and design guidelines were drawn from the bulleted sources mentioned above. The RSA indicator for the CF *community investment* is conducted by *measuring an enterprises' investment contribution to meet a community's (affected stakeholders) social, economic, cultural, technical, environmental, organizational, and other needs.*

Step 5: The CF and DC list for the economic and social domain was categorized then into one of the criteria groupings.

Step 6: Post the grouping, it was observed that the CF could be grouped under three categories: system, service, and product (related to the AM characteristics)-level. This helped in viewing each criterion (like *1. Market Position and Competitiveness*) from the system, service, and product-level and hence, observe and identify the connections between the levels to achieve sustainability. That will further emphasize that a product is not a standalone entity but is composed of the associated system and services. They together create an impact on the environmental, social, and economic dimension of sustainability. Thus, the initial categorization, as mentioned in [Figure 6.8](#), was dropped. An example of the same is illustrated below in [Table 6.4](#).

Table 6.4. Categorization of the economic and social dimension critical features at three levels: system, service, and product.

Category	Critical Features	Initial Categorization		
		Diagnostic Criteria	Sub-diagnostic Criteria	Rapid Sustainability Assessment Indicator
PSS providers' Organizational Characteristics	Business Plan	Effectiveness of Business Plan	Marketing Strategy	Whether the enterprise has a business plan, or an up-to-date document articulates revenue streams, a growth plan, and an operational action plan that projects the future generation of financial resources.
			Financial Strategy	
Investment Strategy				
	Product Strategy		Objectives to achieve and the strategy to implement.	
	Competitiveness	Business development	-	Access to market information, price transparency, reference to similarly priced products, quality awareness, record keeping, business sustainability

		Differentiation	-	In practices for product/ output quality, compliance/ availability of certification/ standards, price premium possibility
		Efficiency	-	Technical, cost, resource efficiency
	Governance	Customers' Perception	-	How do customers perceive the offering?
		Customers' Participation	-	Are customers engaged in providing the offering?
	Services	Financial Services	-	Are these services made available?
		Training Services	-	
		Repair/ Maintenance Services	-	
	Risk Management	Risk Management	Internal Risks External Risks	Whether the enterprise has put in place a plan to reduce and adapt itself against risks (price, production, market and credit risk, unstable employment relations, unavailability of the workforce, conflicts with the community and other stakeholders, natural disasters, diseases, and climate change) that could potentially threaten the business.
Product Characteristics	Diversification	Diversification	-	What is the offering? Is it diversified?
	Quality	Certifications	-	Are certifications for the product available? Is it common to have these certifications for this category of products?
		Quality of output	-	Does the machine improve the quality of the output significantly?
		Competitive quality	-	How does the machine perform in comparison to competitive offerings?
Redefined Categorization				
Criterion: 1. Market position and competitiveness				
Category	Critical Features	Diagnostic Criteria	Rapid Sustainability Assessment Indicator	
System Level	Market Position and Competitiveness	Strength of the market position and competitiveness at the system level	Does the PSS <ul style="list-style-type: none"> ◆ Has a marketing strategy articulating the customers and how to reach them? Which marketing channels need to be secured to reach the customers? 	
Service Level	Market Position and Competitiveness	Strength of the market position and competitiveness due to the services offered	<ul style="list-style-type: none"> ◆ Has an up-to-date document articulating revenue streams, growth plan, and an operational action plan that projects the generation of financial resources for the future? ◆ Invest in research and development, marketing, infrastructure development, training, etc.? What is the strategy for the same? ◆ Has a weak market position in the current system? Is it aware of the possibilities for improving the same but is not using them? Why? What are the current and future threats to the PSS's market position?	

Agricultural Machine Characteristics	Market Position and Competitiveness	Strength of the market position and competitiveness due to the Product	<ul style="list-style-type: none"> • What type of product strategy does the PSS have? • How is it different or similar to that of its competitors? • How easy it is for another entity to offer the same product?
--------------------------------------	-------------------------------------	--	--

6.2.8. How to use G-SAM?

Figure 6.9 presents a snapshot of the G-SAM and the flowchart for using it. SAM consists of three tables, one for each dimension. A designer must first tick the columns applicable for the project at hand by reading through the CF and DC. Next, the designer conducts an analysis of the existing context (products/ services/ processes) using the *Rapid Sustainability Assessment Indicators* against the applicable columns. Post assessment, intervention priority is set to the criterion. After that, the designer ideates using the design cues presented under the *Design Guidelines* against the relevant columns.

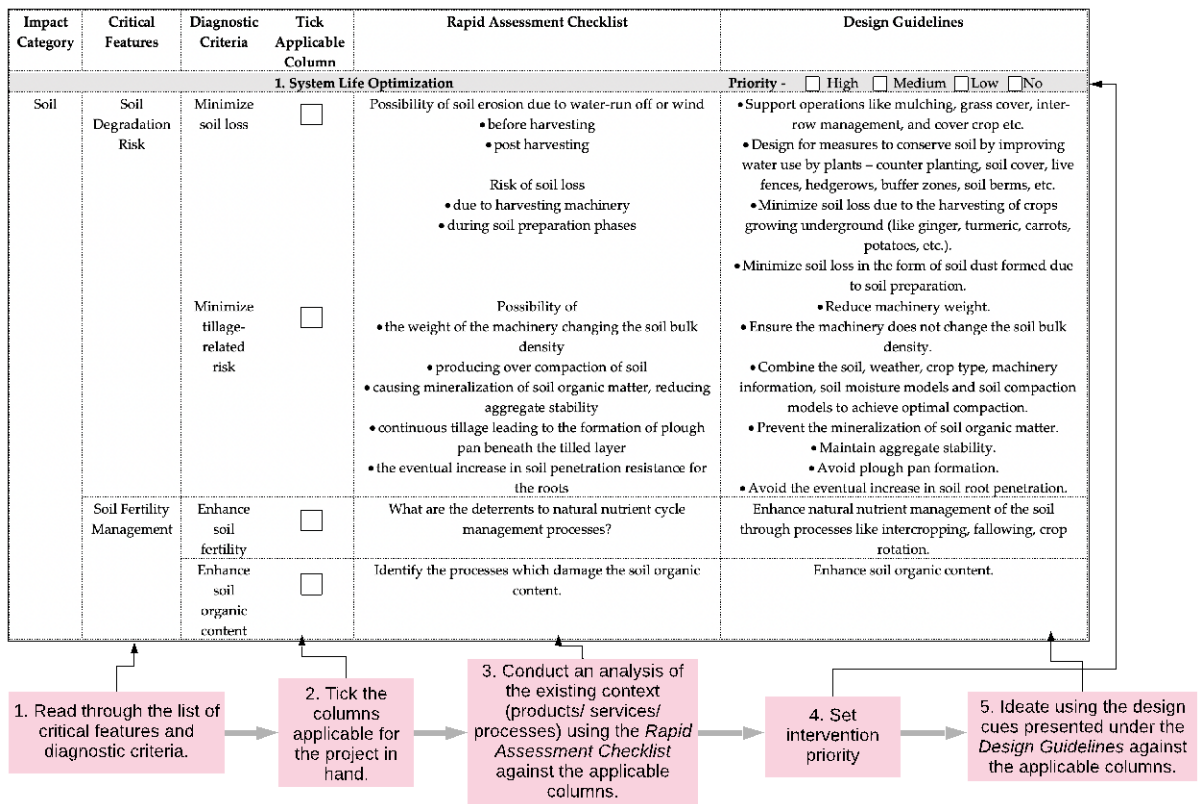

Figure 6.9. Snapshot of G-SAM and flowchart for using it.

6.3. G-SAM

Figure 6.10 presents the structure of G-SAM demarcated into three-levels: Dimension, Criterion, and Impact Category. All criteria have three common impact categories: System-Level, Service-Level, and Agricultural Machine Characteristics (Product-Level) to aid in viewing and identifying the connections between the levels to achieve sustainability. The environmental dimension has additional impact categories, drawn from the physical systems of an agricultural ecosystem. G-SAM is presented in Table 6.5, Table 6.6, and Table 6.7.

6.3.1. Environmental Dimension

Table 6.5. G-SAM – Environmental Dimension

Note: The system here consists of the AM, its support products, processes, services and infrastructure. Tick column if the CF and DC are applicable for the project.

Impact Category	Critical Features	Diagnostic Criteria	<input checked="" type="checkbox"/>	Rapid Sustainability Assessment Indicators	Design Guidelines
1. System Life Optimization					
Priority: <input type="checkbox"/> High <input type="checkbox"/> Medium <input type="checkbox"/> Low <input type="checkbox"/> No					
Soil	Soil Degradation Risk	Minimize soil loss	<input type="checkbox"/>	<ul style="list-style-type: none"> ◆ Possibility of soil erosion due to water-run off or wind <ul style="list-style-type: none"> ➢ before harvesting ➢ post harvesting ◆ Risk of soil loss <ul style="list-style-type: none"> ➢ due to harvesting machinery ➢ during soil preparation phases 	<ul style="list-style-type: none"> ◆ Support operations like mulching, grass cover, inter-row management, and cover crop etc. ◆ Design for measures to conserve soil by improving water use by plants – counter planting, soil cover, live fences, hedgerows, buffer zones, soil berms, etc. ◆ Minimize soil loss due to the harvesting of crops growing underground (like ginger, turmeric, carrots, potatoes, etc.). ◆ Minimize soil loss in the form of soil dust formed due to soil preparation.
		Minimize tillage-related risk	<input type="checkbox"/>	Possibility of <ul style="list-style-type: none"> • the weight of the machinery changing the soil bulk density • producing over compaction of soil • causing mineralization of soil organic matter, reducing aggregate stability • continuous tillage leading to the formation of plough pan beneath the tilled layer • the eventual increase in soil penetration resistance for the roots 	<ul style="list-style-type: none"> ◆ Reduce machinery weight. ◆ Ensure the machinery does not change the soil bulk density. ◆ Combine the soil, weather, crop type, machinery information, soil moisture and compaction models to achieve optimal compaction. <ul style="list-style-type: none"> ◆ Prevent the mineralization of soil organic matter. ◆ Maintain aggregate stability. ◆ Avoid plough pan formation. ◆ Avoid the eventual increase in soil root penetration.
	Soil Fertility Management	Enhance soil fertility	<input type="checkbox"/>	What are the deterrents to natural nutrient cycle management processes?	Enhance natural nutrient management of the soil through processes like intercropping, fallowing, crop rotation.
		Enhance soil organic content	<input type="checkbox"/>	Identify the processes which damage the soil organic content.	Enhance soil organic content.
Water	Water extraction	Reduce water extraction	<input type="checkbox"/>	<ul style="list-style-type: none"> ◆ Is excessive water extraction happening due to the PSS? ◆ Is a large part of this water wasted or polluted due to the operations? 	<ul style="list-style-type: none"> ◆ Reduce water extraction. ◆ Recycle and reuse the water for the operations. ◆ Treat the water before safe release into the source. ◆ Reuse the treated water for secondary purposes.

	Water Stress	Enhance recharge rates	<input type="checkbox"/>	Are ways to recharge water sources being practiced?	Design for rainwater harvesting.
		Balance use and recharge rates	<input type="checkbox"/>	<ul style="list-style-type: none"> ◆ Are water use and recharge rate in balance? ◆ Is there a seasonal imbalance in this ratio resulting in water shortage? <ul style="list-style-type: none"> ◆ Is the groundwater getting depleted? ◆ Are there disputes amongst stakeholders over balancing use and recharge rates? 	<ul style="list-style-type: none"> ◆ Balance the water use and recharge rate. ◆ Get the community to take charge of recharging local water resources. ◆ Mobilize other stakeholders like NGOs, CSR funding, local government, etc. for recharging local water resources. ◆ Design for local action to improve water quality using citizen science. ◆ Support processes like mulching, water diversion structures, suitable row arrangements as per soil and rainfall characteristics, etc.
Biodiversity	Loss of biodiversity	Maintain/ restore integrity, diversity and functioning of ecosystems	<input type="checkbox"/>	Does the system damage the species diversity/ density/ their habitat? That can happen due to the use of machinery or allied processes.	<ul style="list-style-type: none"> ◆ Design systems <ul style="list-style-type: none"> ➢ to protect/ let thrive earthworms, bees, ants, birds and other life forms. ➢ for activities like intercropping to control weeds without/ with less use of chemicals. ➢ for ecological compensation areas like hedges, trees etc. to act as a hotspot for biodiversity on-farm. ➢ to encourage the use of rare, traditional or indigenous livestock/ plant breeds etc.
Productivity	Yield and productivity	Enhance yield and productivity	<input type="checkbox"/>	Is there a foreseeable impact of the system on produce/ productivity/ yield in the immediate and long-term?	Design for processes which balances productivity and yield in the immediate and long-term.
		Prevent losses	<input type="checkbox"/>	Is there a foreseeable impact of the system on produce being lost?	Design for processes which prevents produce loss.
System Level	System Life	System life optimization due to system design	<input type="checkbox"/>	<ul style="list-style-type: none"> ◆ Identify the lifespan of different components used in the system. Do some of them wear out faster than others? Which are the components with short lifespan? ◆ What are the disposable, compostable and reusable components in the system? 	<ul style="list-style-type: none"> ◆ Complement with services and infrastructure for training, maintenance, repair, substitution, upgradation (technical/ cultural/ aesthetical), reuse, repurposing, composting, end-of-life collection, etc. ◆ Offer services & infrastructure to enable sharing/ reusing/ second hand selling/ repurposing/ disposal, etc.
Service Level		(...) service design	<input type="checkbox"/>	<ul style="list-style-type: none"> ◆ Is the infrastructure needed for disposing of/ composting/reusing available? ◆ Identify parts of the system that tend to be technologically/ culturally/ aesthetically obsolete. ◆ Is the system/ its components individually used when it can be more efficiently consumed by sharing? 	<ul style="list-style-type: none"> ◆ Offer services and infrastructure for allied processes and products <ul style="list-style-type: none"> ◆ Offer support infrastructure and platforms ◆ Design to encourage user care for the system. ◆ What other services can improve system life? ◆ Combine specific processes and stages to optimize system life?
Agricultural Machine Characteristics		(...) product design	<input type="checkbox"/>	<ul style="list-style-type: none"> ◆ Are maintenance/ upgradation/ training services available? 	<ul style="list-style-type: none"> ◆ What alternative ways of producing can be used in a given scenario to optimize the system life? ◆ Design product platforms to cater to multiple contexts and usages.

				<ul style="list-style-type: none"> ♦ What are the product/ service/ system/ processes responsible for reducing system life? ♦ Does the PSS have auto-optimization/ data gathering and modeling possibility/ monitoring possibility in terms of system life optimization? 	<ul style="list-style-type: none"> ♦ Design for optimal product life span. ♦ Build-in automation/ intelligent systems which can auto-optimize or automate/ gather data/ monitor processes for system life optimization?
2. Optimization of Resource Management				Priority: <input type="checkbox"/> High <input type="checkbox"/> Medium <input type="checkbox"/> Low <input type="checkbox"/> No	
Soil	Residue mismanagement	Optimization of residue management practices	<input type="checkbox"/>	<ul style="list-style-type: none"> ♦ Is the residue seen as a resource? ♦ Are the residue management practices energy efficient? ♦ Do they release toxic emissions? ♦ How expensive are alternate residue management processes? ♦ What is the general attitude of the users towards the various residue management processes? 	<ul style="list-style-type: none"> ♦ Optimize the energy, toxicity and soil health by optimizing residue management practice selection – burning, removal or incorporation into the soil. ♦ Use residue for energy generation. ♦ Design services and infrastructure to aid optimal residue management.
	Imbalanced nutrient mining	Optimized local nutrient mining	<input type="checkbox"/>	<ul style="list-style-type: none"> ♦ Is nutrient mining balanced? 	<ul style="list-style-type: none"> ♦ Design for nutrient balancing like real-time nutrient checking, inter-cropping possibility.
Water	Water use practices	Responsible farmer irrigation behavior	<input type="checkbox"/>	<ul style="list-style-type: none"> ♦ How does the farmer irrigation behavior affect water use? ♦ What is the relationship between water quantity and productivity? Is it sustainable? ♦ Are there risks to water quality due to manure, silage leachate, wastewater, etc.? 	<ul style="list-style-type: none"> ♦ Design for/ using optimal irrigation technologies, timing, availability improvement. ♦ Localize and adapt irrigation technologies. ♦ Increasing water reuse and recycling through behaviour change and product/ system/ service design support. ♦ Identify the relationship between water quantity and productivity. Design water use practices accordingly.
	Water use efficiency	Water use efficiency	<input type="checkbox"/>	<ul style="list-style-type: none"> ♦ Is the absolute water use for the purpose high as compared to benchmark situations? 	<ul style="list-style-type: none"> ♦ Introduce sensors and other automation features to improve water efficiency. ♦ Design for reuse/ recycling of water. ♦ Design considering the nature of input water source (lake/ canal/ underground, etc.)
Material Cycles	Nutrient self-sufficiency	Nutrient self-sufficiency	<input type="checkbox"/>	<ul style="list-style-type: none"> ♦ What are the nutrients required in the system? ♦ How does the sourcing affect the system's environmental, social and economic dimension? 	<ul style="list-style-type: none"> ♦ Design the system to achieve nutrient self-sufficiency – crop or livestock nutrient demand is covered from farm sources.
System Level	Resource Management	Optimization of resource management through system design	<input type="checkbox"/>	<ul style="list-style-type: none"> ♦ Is their wasteful use of inputs (seeds/fertilizers/ pesticides/ water/ energy use) due to the system configuration? ♦ Does the system consume high quantities of energy/ natural resources/ consumables/ time/ labor/ skills? 	<ul style="list-style-type: none"> ♦ Device ways (product/ service/ system) to optimize the use of inputs – seeds/ fertilizers/ pesticides/ water/ energy. ♦ Complement inputs with support services to enable optimal use. ♦ Design enabling services & platforms to share products and infrastructure.

Service Level		(...) service design	<input type="checkbox"/>	<ul style="list-style-type: none"> ♦ Are the AM and its support products/ processes highly material-intensive? ♦ What are the products/ services/ sub-systems/ processes responsible for non-optimal resource management? 	<ul style="list-style-type: none"> ♦ Design comprehensive pay per use platforms (result-oriented PSS) to encourage providers and manufacturers to optimize resource consumption in order to maximize profits. ♦ Design for resource-saving technologies and practices. In case the cost of such equipment goes high up, design for financing mechanisms. <ul style="list-style-type: none"> ♦ Design to enable efficient collective consumption. ♦ Design training programs to improve resource utilization. ♦ Create appropriate partnerships. ♦ Design to encourage and facilitate eco-efficient consumption patterns. ♦ Design for system automation to optimize resource consumption. <ul style="list-style-type: none"> ♦ Design for outsourcing to optimize economies of scale. ♦ Design feedback mechanism to encourage optimization of resource consumption. ♦ Optimize material and energy expenses in maintenance and repairs.
Agricultural Machine Characteristics		(...) product design	<input type="checkbox"/>	<ul style="list-style-type: none"> ♦ Is the machine typology optimal with respect to human energy required, machine energy required and purpose? ♦ Does the PSS have auto-optimization/ data gathering and modeling possibility/ monitoring possibility in terms of resource use like water, energy and processes? ♦ What are the products/ processes responsible for non-optimal resource management? 	<ul style="list-style-type: none"> ♦ Optimize machine typology with respect to human energy required, machine energy required and purpose. <ul style="list-style-type: none"> ♦ Design soil macronutrient sensing for precision agriculture. ♦ What alternative methods/ tools/ processes can be used in a given scenario to optimize environmental impact? <ul style="list-style-type: none"> ♦ Using sensors to switch on and off processes and devices. ♦ In-field route planning, local weather responsive control system, etc. ♦ What alternative ways of producing can be used in a given scenario to optimize resource management? ♦ Design to set the default value of AM at minimum resource consumption. <ul style="list-style-type: none"> ♦ Design to facilitate the user in saving resources.
3. Transportation/ distribution reduction					Priority: <input type="checkbox"/> High <input type="checkbox"/> Medium <input type="checkbox"/> Low <input type="checkbox"/> No
System Level	Transportation/ distribution	Optimization of transportation / distribution through system design	<input type="checkbox"/>	<ul style="list-style-type: none"> ♦ Identify the system components (products/ raw materials/ semi-finished components/ services/ processes/ people) that need transportation. What transportation systems and infrastructure are used? Is it excessive? Is it efficient? ♦ How well are the existing transportation system and infrastructure used? ♦ Does the transportation/ distribution require vast volumes of packaging material? 	<ul style="list-style-type: none"> ♦ Design the PSS for auto-optimization/ data gathering and modeling possibility/ monitoring possibility to reduce transportation/ distribution need. ♦ Design for upgradation/ information exchange/ training etc. using the digital infrastructure. Design for supporting partnerships. ♦ Strategize for local partnerships and capabilities to outsource manufacturing/ assembly/ repairs/ training/ recycling etc. <ul style="list-style-type: none"> ♦ Enable reuse/ recycling of packaging locally.

Service Level		(...) service design	<input type="checkbox"/>	<ul style="list-style-type: none"> ◆ Does the PSS have auto-optimization/ data gathering and modeling possibility/ monitoring possibility to reduce transportation/ distribution? 	<ul style="list-style-type: none"> ◆ Design for remote operations/ repairs. ◆ Design services and platforms to enable <ul style="list-style-type: none"> ◆ local resources use ◆ local support products use ◆ local/ remote maintenance, repairing, training, upgradation ◆ local/ on-site manufacturing/ assembly ◆ Design for logistic integration/optimization with other services?
Agricultural Machine Characteristics		(...) product design	<input type="checkbox"/>		<ul style="list-style-type: none"> ◆ Design for <ul style="list-style-type: none"> ➢ alternate manufacturing/ assembly to reduce transportation/ distribution? ➢ transportation/ distribution optimization, like design for stack-ability. <ul style="list-style-type: none"> ➢ minimal packaging or reuse of packaging. ➢ matching local manufacturing capabilities.
4. Waste minimization/valorization priority					Priority: <input type="checkbox"/> High <input type="checkbox"/> Medium <input type="checkbox"/> Low <input type="checkbox"/> No
Waste	Generation of waste	Minimize waste generation	<input type="checkbox"/>	<ul style="list-style-type: none"> ◆ Does the system produce high amounts/ volume of waste per unit of produce? <ul style="list-style-type: none"> ◆ Is heat generated by machines/ processes wasted? 	<ul style="list-style-type: none"> ◆ Design for waste heat recovery from machinery/ burning of residue and similar agricultural y-products. <ul style="list-style-type: none"> ◆ Design for recycling/reuse. ◆ Design to aid segregation for end-of-life treatment. <ul style="list-style-type: none"> ◆ Design for trapping pollutants. ◆ Design to encourage or make it easy and cheap for users to adopt environment-friendly disposal/ end-of-life treatment. ◆ Design to aid the use of residue or biomass generated for nutrient balancing/ nutrient generation for sale.
	Utilization of waste	Maximize waste valorization	<input type="checkbox"/>	<ul style="list-style-type: none"> ◆ Is the biomass generated due to the system operations optimally used for various purposes like nutrient balancing, nutrient generation (for sale) and energy recovery through incineration? <ul style="list-style-type: none"> ◆ Does the waste generated ends up being incinerated? Is energy recovery in any form done while it is incinerated? Does incineration cause pollution? <ul style="list-style-type: none"> ◆ Is waste reused or recycled? ◆ Is waste segregation practiced? ◆ Is biodegradable waste appropriately used to serve as a nutrient? 	
Material Cycles	Materials used in the manufacturing of the machine	Scrap value optimization	<input type="checkbox"/>	<ul style="list-style-type: none"> ◆ Do the machines involved have after use-value for some other activities? ◆ Can the user benefit from a particular disposal method like scrap or incineration or repurposing? 	<ul style="list-style-type: none"> ◆ Design for after use-value for some other activities. ◆ Design for a profitable and responsible disposal method like scrap or incineration or repurposing.
System Level	Generation/Utilization of waste	Waste minimization/valorization	<input type="checkbox"/>	<ul style="list-style-type: none"> ◆ What are the product/ support products/ packaging/ service/ sub-systems/ processes specifically responsible for waste generation? 	<ul style="list-style-type: none"> ◆ Design a PSS which offers take-back services to reuse/ re-manufacture / recycle/ recover energy/ compost the AM/ its parts and support products. <ul style="list-style-type: none"> ◆ Design to aid the creation of partnerships to aid the same.

		through system design	<input type="checkbox"/>	<ul style="list-style-type: none"> ◆ Which of these wastes end up in landfill or are incinerated on-site producing pollutants? 	
Service Level		(...) service design	<input type="checkbox"/>	<ul style="list-style-type: none"> ◆ Does the system produce high quantities of this kind of waste? ◆ Does the PSS have auto-optimization/ data gathering and modeling possibility/ monitoring possibility for waste minimization/ valorization? ◆ Is support infrastructure/ service for other cleaner end-of-life processes available, and at what cost? 	<ul style="list-style-type: none"> ◆ Design services for ➢ reuse/ re-manufacture / recycle/ recover energy/ compost components of the AM, its support products and agricultural y-products generated. ➢ training and maintenance to optimize AM and its support products' life. ➢ aiding the selection of appropriate capacity AM for a given context.
Agricultural Machine Characteristics		(...) product design	<input type="checkbox"/>		<ul style="list-style-type: none"> ◆ Design products ➢ for alternate ways of producing for waste minimization/ valorization. ➢ easy disassembly and maintenance for high wear and tear parts. ➢ robust machines for longer life. In case the price of such an AM goes up, consider appropriate financing schemes to be bundled along with it. ➢ for auto-optimization/ data gathering and modeling possibility/ monitoring possibility for waste minimization/valorization.
5. Conservation/ biocompatibility					
Priority: <input type="checkbox"/> High <input type="checkbox"/> Medium <input type="checkbox"/> Low <input type="checkbox"/> No					
Energy	Sustainable Energy Sources	Improve the share of sustainable energy source	<input type="checkbox"/>	<ul style="list-style-type: none"> ◆ Are sustainable energy sources being used? ◆ What is the impact of the energy sources used? ◆ What share of energy used comes from sustainable sources? ◆ Energy is used for what all purposes? 	<ul style="list-style-type: none"> ◆ Calculate the energy required for various purposes like transportation, use, and disposal. Identify which can be replaced by sustainable sources or less polluting sources.
Water	Water and wastewater quality	Improve water and wastewater quality	<input type="checkbox"/>	<ul style="list-style-type: none"> ◆ Is the water and wastewater quality monitored? ◆ Do the water, and the wastewater meet legal thresholds or widely accepted recommendations? ◆ Is the wastewater treated before release into the environment? 	<ul style="list-style-type: none"> ◆ Design for water reuse/ water treatment if toxicity is involved/ proper disposal.
	Leaching during nutrient/ pesticide storage and application	Minimize leaching during nutrient/ pesticide storage and application	<input type="checkbox"/>	<ul style="list-style-type: none"> ◆ Is there a possibility of leaching of nutrients/ pesticides during storage/ application/ cleaning of storage containers and equipment, etc? ◆ Is the frequency and intensity of such leakages high? ◆ Is the precision and efficiency, timing or conditions of the application responsible for the leakage? ◆ Is there a possibility of groundwater contamination? 	<ul style="list-style-type: none"> ◆ Design for water reuse/ water treatment if toxicity is involved/ proper disposal. ◆ Design to prevent groundwater contamination. ◆ Design to make it easy for the user to prevent contaminations.
	Water conservation	Enhance water conservation measures	<input type="checkbox"/>	<ul style="list-style-type: none"> ◆ Are water conservation measures adopted? ◆ Does the process/ product consume vast amounts of water? ◆ Does the product make it too easy to mine lot of water which might get eventually wasted? 	<ul style="list-style-type: none"> ◆ Design to ➢ support practices to conserve water – drip irrigation, catchments, water-efficient processing, etc. ➢ make it easy for the user to conserve water.

		Improve water contamination prevention measures	<input type="checkbox"/>	<ul style="list-style-type: none"> ♦ Are there processes like crop processing/ animals/ cleaning of agrochemical application equipment etc. which can contaminate water or generate vast amounts of wastewater? 	<ul style="list-style-type: none"> ➤ encourage sustainable behavior with respect to water conservation. ♦ Design practices and tools to prevent water contamination due to wastewater from crop processing/ animals/ cleaning of agrochemical application equipment etc.
System Level	Conservation/ biocompatibility	Enhance conservation and biocompatibility through system design	<input type="checkbox"/>	<ul style="list-style-type: none"> ♦ Does the system use the energy produced from fossil fuels/ exhausting resources/ on-farm biomass burning? ♦ Does the system use non-renewable materials for the production processes of its products, support products and processes, packaging and infrastructure? ♦ What are the product/ service/ system/ processes responsible for bringing in bio-incompatibility in any form? ♦ Does the system enable (un)sustainable practices? ♦ Does the PSS have auto-optimization/ data gathering and modeling possibility/ monitoring possibility to achieve conservation and biocompatibility? 	<ul style="list-style-type: none"> ♦ Design partnerships ➤ to produce decentralized sustainable energy at affordable costs. ➤ for material recycling and usage of recycled materials for manufacturing. ♦ Design to encourage the adoption of local renewable energy and biodegradable materials. ♦ Enable and encourage sustainable practices like conservation agriculture, organic fertilizing, organic farming, intercropping, etc.
Service Level		(...) service design	<input type="checkbox"/>		<ul style="list-style-type: none"> ♦ Design services to train in production and usage of renewable energy and materials if local capability is absent. ♦ Introduce services for cost-effective collection and treatment of toxic and harmful resources. ♦ Introduce support services to train locals in sustainable practices like conservation agriculture, organic fertilizing, organic farming, intercropping, etc.
Agricultural Machine Characteristics		(...) product design	<input type="checkbox"/>		<ul style="list-style-type: none"> ♦ Design AM/ support products for alternative ways of producing (like conservation agriculture, organic fertilizing, organic farming, intercropping, etc.) to achieve conservation/ biocompatibility. ♦ Design the PSS for auto-optimization/ data gathering and modeling possibility/ monitoring possibility to achieve conservation and biocompatibility.
6. Toxicity Reduction					
					Priority: <input type="checkbox"/> High <input type="checkbox"/> Medium <input type="checkbox"/> Low <input type="checkbox"/> No
Soil	Agricultural soil toxicity	Minimize pollution caused by pesticides, acidifying fertilizers & fertilizers	<input type="checkbox"/>	<ul style="list-style-type: none"> ♦ Is nutrient balancing skewed? ♦ Is the method of nutrient application causing toxicity to soil/ water/ air/ animals/ humans? 	<ul style="list-style-type: none"> ♦ Design support to ➤ apply manure using methods to minimize ammonia and NOx emissions. ➤ facilitate the use of alternatives like legumes or nitrification inhibitors to reduce NOx emissions ➤ enable practices like deep placement/ or basal application of fertilizer while seeding/ planting.

		containing heavy metals			
		Minimize salination risk	<input type="checkbox"/>	Is there a risk of soil salination due to current soil and water management processes?	<ul style="list-style-type: none"> ◆ Design for integrated soil and water management scenarios for salinity management. ◆ Use auto-optimization/ data gathering and modeling possibility/ monitoring possibility for controlling soil salinity.
Energy	Environmental effects of energy carriers used	Minimize the environmental effects of energy use and storage	<input type="checkbox"/>	What are the toxic emissions to air, water and soil due to the source of energy and energy-storing or carrying means?	<ul style="list-style-type: none"> ◆ Use cleaner energy contextualized to the farm scenario. ◆ Reduce emissions by using catalytic converters or similar attachments. <ul style="list-style-type: none"> ◆ Use cleaner energy storage. ◆ Design services around clean energy production and consumption at reasonable costs. ◆ Design services/ infrastructure for clean disposal of energy storage devices.
Air	GHG emissions	Reduction in GHG emissions	<input type="checkbox"/>	<ul style="list-style-type: none"> ◆ How do you compare the GHG emissions for per unit of product/ service against similar benchmark? <ul style="list-style-type: none"> ◆ Is the net GHG emissions high? ◆ Are the exhaust gases a source of major pollution? ◆ Is the emission of ammonia, CO, NO_x, SO_x, photochemical oxidants, particulate matter, pesticides, microorganisms, ozone-depleting substances a concern? ◆ Does the machinery configuration, soil condition, weather, technical and socio-economic factors influence the emissions? <ul style="list-style-type: none"> ◆ Is CFC recovery enabled? 	<ul style="list-style-type: none"> ◆ Use other production processes (like a different way of tilling the land). <ul style="list-style-type: none"> ◆ Optimize soil moisture content to reduce emissions. ◆ Design for behavior change of farmers to reduce emissions. ◆ Optimize the machinery configuration with respect to soil condition, weather, technical parameters and usage behavior to reduce emissions. ◆ Design targeted spraying of fertilizers and pesticides to reduce the emission of ammonia, CO, NO_x, SO_x, photochemical oxidants, particulate matter, pesticides, etc. ◆ Eliminate the use of CFCs or design ways for better recovery. ◆ Use catalytic converters + particle filters for vehicles/ farm machinery running on diesel.
		Improve carbon sequestration	<input type="checkbox"/>	<ul style="list-style-type: none"> ◆ Are carbon sequestration measures taken? 	<ul style="list-style-type: none"> ◆ Design for carbon sequestration.
	Fugitive Dust	Fugitive dust minimization	<input type="checkbox"/>	<ul style="list-style-type: none"> ◆ Is dust generated by open environment vehicles/ farm machinery while running on unpaved roads? <ul style="list-style-type: none"> ◆ Is dust produced during farm operations? 	<ul style="list-style-type: none"> ◆ Design ways to optimize soil moisture content to reduce dust creation. <ul style="list-style-type: none"> ◆ Design dust settling/ collecting mechanisms. ◆ Design supporting protective gear.
Waste	Toxicity	Toxicity reduction	<input type="checkbox"/>	<ul style="list-style-type: none"> ◆ Is the weight/ volume of waste transported/ imported/ exported/ treated hazardous by the Basel Convention? <ul style="list-style-type: none"> ◆ Is waste storage risky? 	<ul style="list-style-type: none"> ◆ Design for <ul style="list-style-type: none"> ➤ leakage risk-free storage. ➤ non-hazardous wastes.
System Level	Toxicity	Toxicity reduction	<input type="checkbox"/>	<ul style="list-style-type: none"> ◆ What are the products/ service/ system/ processes responsible for toxic emissions? 	<ul style="list-style-type: none"> ◆ Create partnerships <ul style="list-style-type: none"> ➤ for recycling/ reuse of toxic substances.

	through system design		<ul style="list-style-type: none"> ♦ What is the nature of toxicity for the workers/ users involved in the system? <ul style="list-style-type: none"> ♦ What are the toxicity risks involved during ♦ Transportation • Distribution • Servicing and maintenance • Usage • Storage • End-of-life? 	<ul style="list-style-type: none"> ➢ to aid in reducing/ managing toxic emissions during transportation, distribution, servicing and maintenance, usage, storage, end-of-life. ♦ Design training programs to enable users/ stakeholders in handling and management of toxic substances. <ul style="list-style-type: none"> ♦ Design services <ul style="list-style-type: none"> ➢ for the recovery/treatment of toxic/harmful resources. ➢ to avoid/minimize toxicity/dangerousness of materials/energy. • Design alternative ways of producing for toxicity reduction? • Design the PSS for auto-optimization/ data gathering and modeling possibility/ monitoring possibility to achieve toxicity reduction. • Design protective gear for handling toxic substances.
Service Level	(...) Service design	<input type="checkbox"/>		
Agricultural Machine Characteristics	(...) Product design	<input type="checkbox"/>		

6.3.2. Economic Dimension

Table 6.6. G-SAM – Economic Dimension

Note: The system here consists of the AM, its support products, processes, services and infrastructure. Tick ✓ column if the CF and DC are applicable for the project.

Impact Category	Critical Features	Diagnostic Criteria	✓	Rapid Sustainability Assessment Indicators	Design Guidelines
1. Market Position and Competitiveness					
Priority: <input type="checkbox"/> High <input type="checkbox"/> Medium <input type="checkbox"/> Low <input type="checkbox"/> No					
System Level	Market Position and Competitiveness	Strength of the market position and competitiveness due to system design	<input type="checkbox"/>	<ul style="list-style-type: none"> ♦ Does the PSS <ul style="list-style-type: none"> ➢ Has a marketing strategy articulating the customers and how to reach them? Which marketing channels need to be secured to reach the customers? ➢ Has an up-to-date document articulating revenue streams, growth plan, and an operational action plan that projects the generation of financial resources for the future? <ul style="list-style-type: none"> ➢ Invest in research and development, marketing, infrastructure development, training, etc.? What is the strategy for the same? ➢ Has a weak market position in the current system? Is it aware of the possibilities for improving the same but is not using them? Why? <ul style="list-style-type: none"> ♦ What are the current and future threats to the PSS's market position? 	<ul style="list-style-type: none"> ♦ Re-imagine the PSS to secure/ enhance the current market position. ♦ Re-imagine the PSS to achieve a competitive advantage through price, performance, quality, lifespan, consumer demand fulfillment, etc. <ul style="list-style-type: none"> ♦ Design for unfulfilled/ unmet customer needs. ♦ Design the PSS to expand the customer base. ♦ Observe political, technological, social, cultural, economic, environmental, legal, and other trends. Design a PSS considering long-term and emerging trends. Strategize for a phased introduction of the PSS considering the long-term trends. ♦ Strategize for diversification (product, services, partners, markets, etc.). <ul style="list-style-type: none"> ♦ Value chain improvement through PSS. ♦ Brand image enhancement through the offering. ♦ Identify the key customer groups and their needs. Design and enhance the PSS and the services offered to satisfy these needs.
Service Level		(...) service design	<input type="checkbox"/>		

				<ul style="list-style-type: none"> ◆ Design services to make the new PSS more attractive and desirable than the current market offers. ◆ Design services for the PSS so that customers are more attracted to the sharing model than the ownership model. <ul style="list-style-type: none"> ◆ Ideate to make sharing more economical, convenient, and flexible. ◆ Identify potential customers who are more inclined towards PSS-based consumption rather than ownership—design specifically for them. <ul style="list-style-type: none"> ◆ Identify the collaborators required along the entire value chain. ◆ Design service offerings to enhance brand image/ rebrand to bring forth the PSS quality. 	
Agricultural Machine Characteristics		(...) product design	<input type="checkbox"/>	<ul style="list-style-type: none"> ◆ What type of product strategy does the PSS have? ◆ How is it different or similar to that of its competitors? ◆ How easy it is for another entity to offer the same product? 	<ul style="list-style-type: none"> ◆ Add augmented and add-on features to the product, which makes it more attractive to the customers. ◆ Add the possibility of customization through modular design.
2. Profitability or added value for companies					
System Level	Profitability or added value for companies	Degree of profitability or added value for companies involved in producing the PSS offering due to the system design	<input type="checkbox"/>	<ul style="list-style-type: none"> ◆ For the consortium of PSS providers and other participating stakeholders <ul style="list-style-type: none"> ➢ The profitability of the system attractive? ➢ The profitability of the system adequate for sustainable growth? ➢ Does the structure of the consortium impede its profit-making potential? ➢ Does the competition produce better offers than the consortium and at lower prices? <ul style="list-style-type: none"> ◆ For the value chain <ul style="list-style-type: none"> ➢ Does it have opportunities to create higher value? ➢ Has any other provider exploited these opportunities? 	<p>Priority: <input type="checkbox"/> High <input type="checkbox"/> Medium <input type="checkbox"/> Low <input type="checkbox"/> No</p> <ul style="list-style-type: none"> ◆ Increase the profitability of the PSS for all stakeholders by <ul style="list-style-type: none"> ➢ Decreasing costs ➢ Increasing turnover ◆ Redesign the production and consumption system to increase profits for each stakeholder. <ul style="list-style-type: none"> ◆ Optimize the value chain through PSS offerings. ◆ Reduce material flows in the system to optimize costs. ◆ Create value in the system through non-material elements, which can also reduce costs. <ul style="list-style-type: none"> ◆ Design the PSS for recycling or reuse to reduce the cost. ◆ Increase profits through design, considering the entire production and consumption value chain.
Service Level		(...) service design	<input type="checkbox"/>		<ul style="list-style-type: none"> ◆ Identify partners for <ul style="list-style-type: none"> ➢ Outsourcing activities to improve efficiency and cost structure. ➢ Cost/ investment sharing. ➢ Increasing value creation through service design for the entire value chain. <ul style="list-style-type: none"> ◆ Reduce capital investment through PSS design. ◆ Reduce costs by outsourcing, reducing material goods ownership, organizational changes, etc. ◆ Ideate to enhance return on investment.

					<ul style="list-style-type: none"> ♦ Ideate to create additional value through services so that customers are willing to pay more for the convenience while the services are cost-efficient for the PSS providers. ♦ Improve employees' work productivity by enhancing working conditions, providing training, etc.
Agricultural Machine Characteristics		(...) product design	<input type="checkbox"/>	<ul style="list-style-type: none"> ♦ Is the cost of production of the product very high? ♦ Have appropriate measures (like outsourcing specific manufacturing processes, using concepts of optimizing inventory, etc.) been taken to reduce the production cost? ♦ Is the product priced so that break-even can be reached in a manageable amount of time? <ul style="list-style-type: none"> ♦ Are the customers ready to pay that price? ♦ Is the product designed to optimize the cost of production/ inventory management/ servicing etc.? (for example, modular design, design for easy maintenance, design for reliability) 	<ul style="list-style-type: none"> ♦ Can you design for modularity, design for easy maintenance, and design for reliability? <ul style="list-style-type: none"> ♦ Can you design for optimized production costs? ♦ Can you design for the product's optimal life with components that get damaged more often being easily replaceable? ♦ Can you design this repair job in a manner that the customers can do it themselves? ♦ Increase value creation through product design for the entire value chain.
3. Added value for customers Priority: <input type="checkbox"/> High <input type="checkbox"/> Medium <input type="checkbox"/> Low <input type="checkbox"/> No					
System Level	Added value for customers	Perception of value addition for customers against the costs paid by the customer due to the system design	<input type="checkbox"/>	<p>Considering the entire system, services, and products</p> <ul style="list-style-type: none"> ♦ Do the customers perceive the value/ profits reasonable? ♦ Does it bring forth savings in time, effort, labor, cost, other resources like seeds, fertilizers, transportation, water, etc., for the customer? <ul style="list-style-type: none"> ♦ Does it improve efficiency sufficiently? ♦ Does it offer intangible values (like esteem, experience, belongingness, etc.) to the customer? Is the customer willing to pay for these values, or will it make the offering more attractive? <ul style="list-style-type: none"> ♦ Do competitive offerings bring in higher value? ♦ Do add-on services (like training, credit, repair, maintenance) create additional value for the customers? ♦ Is the consortium of providers or the primary provider perceived favorably due to their quality/ commitment/ investment in R&D/ transparency/ investment in community development, etc.? 	<ul style="list-style-type: none"> ♦ Provide transparency in understanding the implications on livelihoods. <ul style="list-style-type: none"> ♦ Aid to make appropriate choices. ♦ Save customers' costs - direct, indirect, labor, input (fertilizer/ pesticide/ water/ fuel/etc.), recurring, maintenance, depreciation, energy, capital assets, cultivation practices change cost, traceability & record keeping, costs of standard/ certification, cost of allied activities required (input, labor, waste disposal), training cost, etc. <ul style="list-style-type: none"> ♦ Reduce customers' risks. ♦ Offer a better cost to value ratio than competitive offerings. ♦ Offer higher material benefits like increased income, opportunities, savings, reduced debt, taxes, etc. ♦ Offer non-material benefits like pride, satisfaction, customized offerings, leadership, training, etc. <ul style="list-style-type: none"> ♦ Offer flexibility of choice to the customer.
Service Level		(...) services offered	<input type="checkbox"/>		<ul style="list-style-type: none"> ♦ Communicate to positively influence the perception of the customer regarding: <ul style="list-style-type: none"> ➢ Suitability to their economic situation ➢ Value for price

				<ul style="list-style-type: none"> ➤ The difference in the level of income that can happen <ul style="list-style-type: none"> ➤ Degree of risk involved ➤ Costs Involved (How to optimize the direct, indirect, labor, input (fertilizer/ pesticide/ water/ fuel/etc.), recurring, maintenance, depreciation, energy, capital assets, cultivation practices change cost, traceability & record keeping, costs of standard/ certification, cost of allied activities required (input, labor, waste disposal), training costs, etc.) ➤ Quality of product and the output produced ➤ Provide add-on services (like training, credit, repair, maintenance) to create additional value for the customers.
<p>Agricultural Machine Characteristics</p>		<p>(...) product design</p>	<input type="checkbox"/>	<ul style="list-style-type: none"> ♦ What product innovation can increase the income, reduce costs (fixed, recurring, indirect), increase the productivity of the farm activities and the customer (like reduction in chances of personal accident or ill-health, or reduce time and effort for performing activities), and reduce losses? <ul style="list-style-type: none"> ♦ Offer use versatility or do multitasking or multiple tasking. ♦ Aid in obtaining output certification (for example, organic certification)? <ul style="list-style-type: none"> ♦ Design the product for incremental ownership. ♦ Design considering resale value. ♦ Can the product improve the competitiveness of the customers' output?
<p>4. Long-term business development/ risk Priority: <input type="checkbox"/> High <input type="checkbox"/> Medium <input type="checkbox"/> Low <input type="checkbox"/> No</p>				
<p>System Level</p>	<p>Long term business development/ risk</p>	<p>Optimization of long-term business development risks due to system design</p>	<input type="checkbox"/> <p>Considering the entire system, services, and products</p> <ul style="list-style-type: none"> ♦ Is the offering a short-term business? ♦ What factors (like technological, fashion, socio-cultural, political, legal, economic, etc.) threaten the offer? ♦ What are the possible vulnerabilities due to conditions beyond the PSS providers' control (like natural disasters, change in customer behavior), and external sources (like clients, government, legislation, NGOs)? How protected are they from those? <ul style="list-style-type: none"> ♦ Are there competitors providing alternate processes/ products/ companies/services? Who are they, and how strong are they? How can they impact the market size in the future? How are they moving the market size now? ♦ Will the customers' need for the offer ebb? ♦ Do the PSS providers have a sound financial background? 	<ul style="list-style-type: none"> ♦ Improve the innovation capability of PSS providers. ♦ Enhance the organizational flexibility to enable the response to changing market demands. ♦ Design business models for long-term trends (like technological, fashion, socio-cultural, political, legal, economic, etc.). <ul style="list-style-type: none"> ♦ Design for the long-term goals with appropriate in-between phases. ♦ Devise metrics to measure PSS's market success and mechanisms for collection and analysis of the data. ♦ Design for resilience considering possible external risks beyond the PSS's control (like natural disasters, changes in customer behavior, legal requirements, etc.). ♦ Design PSS to distribute and reduce risks (liability, investment, others) amongst PSS providers and various PSS offerings. ♦ Design PSS to build customer loyalty and brand image.

				<ul style="list-style-type: none"> ◆ Do they have a guarantee of production levels? ◆ Do they have a diversified and consolidated income structure from the PSS's sales? ◆ Are there significant risks in how they make contact with potential buyers, negotiate price and conditions, contract and transfer the products and goods? ◆ What are the strengths and level of diversification of the marketing channels that they use? ◆ Do they have appropriate mechanisms to trace their products, customers, spare parts, and so on? 	<ul style="list-style-type: none"> ◆ Diversify income and sources of revenue through multiple PSS offerings. ◆ Create means to manage information, knowledge, and organizational structure to offer robust and flexible PSS. Bring in the right kind of skills to achieve the same (hiring/ partnership building). <ul style="list-style-type: none"> ◆ Build brand image around sustainability and innovation. ◆ Build PSS solutions keeping in mind the effects of environmental legislation (current and forthcoming). ◆ Diversify marketing channels through PSS design. ◆ Design a mechanism to capture knowledge from failures and successes of similar PSS and learn from them.
Service Level		(...) service design	<input type="checkbox"/>		<ul style="list-style-type: none"> ◆ Incorporate services to improve innovation capability (example – training, feedback collection, analysis, monitoring, tracking, etc.). Incorporate it (and maybe monetize it) by sharing it with partners, suppliers, customers, etc.) ◆ Capture and manage stakeholder, employee, and customers' knowledge. ◆ Create an innovation environment in the organization and incentivize it. <ul style="list-style-type: none"> ◆ Reduce liability by substituting product ownership with services. ◆ Plan for services (maybe in partnership) to handle the complete lifecycle of products.
Agricultural Machine Characteristics		(...) product design	<input type="checkbox"/>		<ul style="list-style-type: none"> ◆ Prevent any disruption in the volume of production and quality. ◆ Design mechanisms to trace products, customers, spare parts, and so on. ◆ Design the product as a platform for future product development and sale. <ul style="list-style-type: none"> ◆ Customer loyalty and repeat purchases through product architecture. ◆ Avoid products and materials with a negative sustainability image in the eyes of customers/ legislations.
				5. Partnership/ co-operation	Priority: <input type="checkbox"/> High <input type="checkbox"/> Medium <input type="checkbox"/> Low <input type="checkbox"/> No
System Level	Partnership/ co-operation	Strength of the partnership/ cooperation due to the system design	<input type="checkbox"/>	<ul style="list-style-type: none"> ◆ Are partnerships and co-operations being used to offer the PSS? <ul style="list-style-type: none"> ◆ Does the partnership have a weak market position? ◆ Does the partnership complement each other's capabilities? <ul style="list-style-type: none"> ◆ Are the competitors' partnerships stronger? ◆ Are some internal competencies missing within the current partnership? <ul style="list-style-type: none"> ◆ Are supplier relationships stable? ◆ To what extent is the PSS provider dependent on the leading supplier? 	<ul style="list-style-type: none"> ◆ Incorporate systems for participatory design of PSS with partners, suppliers, customers, and other stakeholders. ◆ Create systems and platforms for partnership and co-operation management. ◆ Identify strategic partners to build competencies, strengthen offerings, and reduce investments, risks, and costs. <ul style="list-style-type: none"> ◆ Balance power distribution between partners and suppliers. ◆ Create a balanced partnership structure involving local, regional, and global partners to achieve an optimal offering and business scenario.

Service Level		(...) service design	<input type="checkbox"/>	<ul style="list-style-type: none"> Does the PSS provider take action and have mechanisms to ensure stable supply and reduce the risk to have input supply shortages? Are the partners, procurements, labor, customers local or global? How does that influence the business? 	<ul style="list-style-type: none"> Improve market value and perception through partnerships. Improve the position in the value chain through strategic partnerships. Devise strategies to stay in synchronization with partners in terms of motivation and goals.
Agricultural Machine Characteristics		(...) product design	<input type="checkbox"/>	<ul style="list-style-type: none"> Does the product typology require partnerships with other stakeholders? Are these partnerships <ul style="list-style-type: none"> local/ regional/ global? effective and sufficient? 	<ul style="list-style-type: none"> Create partnerships considering the product design needs. Design considering local partners/ suppliers' capabilities and offerings. Design training for partners/ suppliers to provide for the value chain activities like manufacturing, operation, distribution, etc.
6. Macro-economic Effect					
System Level	Macro-economic Effect	Macro-economic effect due to system design	<input type="checkbox"/>	Identify macro-economic problems which influence the entire system, services, and products •GDP & Well-being •Unemployment rates • Minimum wages, unions & contracts • National income • Price indices • Output • Consumption • Inflation • Demand • Savings • Investment • Banking & Credit • Energy economics • International trade • International finance • Protectionism • Trade barriers • Fiscal policy • Interaction between public and private sectors • Monopolistic structures • Rebound effects	Priority: <input type="checkbox"/> High <input type="checkbox"/> Medium <input type="checkbox"/> Low <input type="checkbox"/> No <ul style="list-style-type: none"> Design the PSS to utilize the macro-economic aspects best. Design PSS to generate a positive impact on the macro-economic aspects. Design PSS to avoid the adverse effects of the macro-economic aspects.
Service Level		(...) service design	<input type="checkbox"/>		<ul style="list-style-type: none"> Create jobs in the region Use local/ regional resources Create business opportunities in the locality/ region Provide equitable access and opportunities to actors.
Agricultural Machine Characteristics		(...) product design	<input type="checkbox"/>		<ul style="list-style-type: none"> Design the product to create a market for other products belonging to the same or disjoint family in a specific region. Enhance the macro-economy (well-being, employment generation, savings, etc.) through product design.

6.3.3. Social Dimension

Table 6.7. G-SAM – Social Dimension

Note: The system here consists of the AM, its support products, processes, services and infrastructure. Tick column if the CF and DC are applicable for the project.

Impact Category	Critical Features	Diagnostic Criteria	<input checked="" type="checkbox"/>	Rapid Sustainability Assessment Indicators	Design Guidelines
1. Improve employment and working conditions					
Priority: <input type="checkbox"/> High <input type="checkbox"/> Medium <input type="checkbox"/> Low <input type="checkbox"/> No					
System Level	Improve employment and working conditions	Optimize employment and working conditions	<input type="checkbox"/>	<ul style="list-style-type: none"> Are there any problems of discrimination (intentional/ unintentional, long-term/ short-term) in the workplace or in handling the product? Are employees/ workers/ owners being paid or making a living wage that can cover the cost of a nutritious diet, basic acceptable housing, cost of clothing, and other costs required for a decent life? 	<ul style="list-style-type: none"> Design the system considering <ul style="list-style-type: none"> Working conditions that are healthy and safe <ul style="list-style-type: none"> Employment security Reasonable working hours Fair wages

		through system design		<ul style="list-style-type: none"> ◆ Do the workers/ employees have <ul style="list-style-type: none"> ➢ healthy work hours? ➢ no compulsory overtime? ➢ work overload? ➢ Voluntary overtime with extra compensation at a higher rate and additional rest days when the overload period (like harvesting) is over? <ul style="list-style-type: none"> ➢ Regular breaks for needs like sanitation, meals, etc.? ➢ Adequate breaks and rests during peak work times also? ➢ Ability to participate in their cultural activities, speak the language, and practice the religion of their choice (time and space included), freedom of expression? ➢ Ability to enjoy a diet of choice, have time to procure, produce, and prepare meals, have a healthy nutritional diet for themselves and their family? ➢ Leisure time, family time, have a good quality of life? <ul style="list-style-type: none"> ◆ Do employees have opportunities for: <ul style="list-style-type: none"> ➢ Capacity development? ➢ Advancement within the enterprise? ◆ Do the producers have the possibility to adopt improved techniques to make the enterprise more productive, efficient, environment-friendly, innovative, profitable. ◆ Is future generation/ management identified, motivated, trained, and prepared? 	<ul style="list-style-type: none"> ➢ Enhancement of employee satisfaction, motivation, and participation. ➢ Certification like OHSAS 18001 (occupation health and safety), Fair Trade (producers in developing countries are paid a fair price for their work), and others which represent the company's commitment towards social and ethical responsibility.
Service Level		(...) service design	<input type="checkbox"/>		<ul style="list-style-type: none"> ◆ Design or incorporate services (like training programs, communication platforms, tools, recognition, events, conferences, etc.) that <ul style="list-style-type: none"> ➢ Sensitize, avoid or eliminate possible discriminations. ➢ Improve working conditions. ➢ Incorporate checks and balances to prevent forced labor/ child labor/ work overload. ➢ Enable freedom of expression and association, right to collective negotiation. <ul style="list-style-type: none"> ➢ Enable capacity development, career advancement. ➢ Sensitize and inform about health and safety measures. ➢ Improve productivity, efficiency, innovativeness, profitability, sustainability, and social responsibility. ➢ Award achievements, enhance satisfaction, motivation, and participation of employees/ stakeholders. ➢ Provide space and scope for innovations and creativity. ➢ Involve stakeholders in the decision-making processes. ➢ Collaborate to offer good working conditions in the whole value chain.
Agricultural Machine Characteristics		(...) product design	<input type="checkbox"/>	<ul style="list-style-type: none"> ◆ What are the health and safety-related issues during: <ul style="list-style-type: none"> ➢ Manufacturing? - Use? - Maintenance? - Disposal phase? ◆ Is the workplace, operational stages, and equipment and its support/ consumable products safe and have safety measures in place? Does it have potential health hazards associated? <ul style="list-style-type: none"> ◆ Are dangers highlighted using signages? ◆ Are safety equipment and protective gear made available? ◆ Are employees/ labor/ stakeholders informed and trained to: <ul style="list-style-type: none"> ➢ Handle health and safety precautions while engaged with dangerous/ accident prone/ hazardous areas/ equipment/ chemicals and avoid exposure? 	<ul style="list-style-type: none"> ◆ Design the product considering ➢ Design to minimize health and safety risks during manufacturing, use, maintenance/ disposal phase. ➢ Design to minimize discrimination (intentional/ unintentional, long-term/ short-term) in the workplace or in handling the product. <ul style="list-style-type: none"> ➢ Gender-sensitive design ➢ Design for accessibility ➢ Design for ease of learnability ➢ Design considering ergonomics ➢ Design appropriate protective gear

				<ul style="list-style-type: none"> ➤ Use safety equipment and protective gear? ➤ Follow ergonomically correct practices while at work? <ul style="list-style-type: none"> ◆ Is health coverage being provided? ◆ Is access to medical care available for emergencies? ◆ Is social security available for the PSS provider's employees/ the value chain's informal sector workers? 	<ul style="list-style-type: none"> ➤ Design signages and labels for informing potential dangers and precautions to be taken.
2. Improve equity & justice in relation to stakeholders				Priority: <input type="checkbox"/> High <input type="checkbox"/> Medium <input type="checkbox"/> Low <input type="checkbox"/> No	
System Level	Improve equity and justice in relation to stakeholders	Optimize equity and justice in relation to stakeholders through system design	<input type="checkbox"/>	<ul style="list-style-type: none"> ◆ Do the stakeholders have fair access to means of production: <ul style="list-style-type: none"> ➤ agricultural extension services? ➤ training/ conferences/ events/ courses/ other services for knowledge/ skill up-gradation? ➤ necessary equipment and facilities like buildings, storage, transport, repair/ maintenance, spares, upgrades, quality inputs, etc.? ◆ Does the PSS offer fair pricing, which can: <ul style="list-style-type: none"> ➤ provide a living wage to employees? ➤ cover the costs? ➤ cover investments required for future growth? ➤ aid in creating savings? ◆ Are the pricing terms mutually agreeable to involved stakeholders and laid down? ◆ Are business processes laid down and informed to stakeholders? ◆ Are there any unjust relations between the partners, suppliers, subcontractors, sub-suppliers, and customers? ◆ Are conflict/ grievance resolution rules laid down and known to stakeholders? ◆ Are terms of all contracts laid down and known to stakeholders? ◆ Are all parties involved in an agreement free to terminate the same? ◆ Are the financial implications of entering into an agreement clearly stated? ◆ Are the agreement clauses restrictive (e.g., limit the farmer to grow only the agreed crop, limit the supplier to supply only to the PSS provider)? Does that restrict equity and justice? 	<ul style="list-style-type: none"> ◆ Design the system to stimulate and augment <ul style="list-style-type: none"> ➤ fair access to means of production throughout the value chain. ➤ fair and just relationships and partnerships between stakeholders (suppliers, partners, clients, local community/ institutions/ agencies). ➤ equity and justice between stakeholders. <ul style="list-style-type: none"> ➤ fair pricing ➤ transparency in processes, agreements, contracts, and redressals. ➤ participatory action research and participatory design into the system design and functioning. <ul style="list-style-type: none"> ◆ Design to avoid rebound effects.
Service Level		(...) service design	<input type="checkbox"/>		<ul style="list-style-type: none"> ◆ Design or incorporate services (like training programs, communication platforms, tools, recognition, events, conferences, alliances etc.) that <ul style="list-style-type: none"> ➤ stimulate and augment fair and just partnerships. ➤ stimulate and augment fair access to means of production. ➤ facilitate the sharing of knowledge, infrastructure, support tools/ standards with stakeholders. <ul style="list-style-type: none"> ➤ create and maintain democratic structures. ➤ promote the involvement of organizations/ institutions/ partners that enable diffusion of social equity standards. <ul style="list-style-type: none"> ➤ enable conflict/ grievance resolution. ➤ enable information flow between stakeholders. ➤ augment transparency in terms and conditions of engagement. ➤ augment stakeholder's productivity, capacity, health, safety. ➤ facilitate checks and balances on possible discriminations and marginalization. ➤ measure the impact of stakeholder participation

			<ul style="list-style-type: none"> ◆ Are employment contracts clear to the employees? Do they mention: <ul style="list-style-type: none"> ➢ Nature of work? ➢ Working hours? 	<ul style="list-style-type: none"> ➢ adopt standards and tools for certification of socio-ethical certifications. ➢ identify and prevent marginalization.
<p>Agricultural Machine Characteristics</p>		<p>(...) product design</p>	<ul style="list-style-type: none"> ➢ Rules regarding conduct, conflict/ grievance redressal, and terminations of contract? <ul style="list-style-type: none"> ➢ Compensation pay, overtime policy, leaves? <ul style="list-style-type: none"> ◆ Is there any form of forced labor involved? ◆ Is child labor involved in the value chain? ◆ Do stakeholders have freedom of association and collective bargaining? ◆ Are there discriminations based on religion, gender, age, caste, etc., in the entire value chain? <ul style="list-style-type: none"> ◆ Are all stakeholders who are affected by the system identified, endorsed, and involved? ◆ Who are the most vulnerable stakeholders of the system? Are they identified, endorsed, and involved? ◆ Are participatory action research and participatory design part of the PSS's operation procedure? <ul style="list-style-type: none"> ◆ Is the impact of stakeholder participation measured and acknowledged? ◆ Have the pointers from participatory action research and participatory design been incorporated into the system design and functioning? <ul style="list-style-type: none"> ◆ Have the results and conclusions from the participatory action research and participatory design been communicated back to the stakeholders? ◆ What are the barriers in the way of effective engagement of stakeholders? Are strategies in place to overcome those? ◆ Are grievance redressal procedures available for all stakeholders? Are stakeholders satisfied with them? ◆ Are there conflicts of interest between stakeholders? How are they resolved? Are stakeholders satisfied with the resolution? 	<ul style="list-style-type: none"> ◆ Design the product considering <ul style="list-style-type: none"> ➢ the skill set and training facilities of the stakeholders. ➢ the availability of equipment and facilities like buildings, storage, transport, repair/ maintenance, spares, upgrades, quality inputs, etc. <ul style="list-style-type: none"> ➢ economic capabilities of the stakeholders. <ul style="list-style-type: none"> ➢ incremental upgradation. ➢ gender and age inclusiveness.
			<p>3. Enable a responsible and sustainable consumption</p>	<p>Priority: <input type="checkbox"/> High <input type="checkbox"/> Medium <input type="checkbox"/> Low <input type="checkbox"/> No</p>
<p>System Level</p>	<p>Enable a responsible and</p>	<p>Enable a responsible and</p>	<p><input type="checkbox"/> ◆ Do stakeholders have a positive perception regarding their quality of life?</p>	<ul style="list-style-type: none"> ◆ Design the system to enable <ul style="list-style-type: none"> ➢ responsible and sustainable consumption choices.

	sustainable consumption	sustainable consumption through system design		<ul style="list-style-type: none"> ◆ Do stakeholders give regard to the quality of life for other stakeholders in their decision-making processes? ◆ Do the PSS providers and their supply chain actors value social responsibility? <ul style="list-style-type: none"> ◆ Do they enact socially responsible practices? ◆ Do the stakeholders value care for the environment? ◆ Do they enact environment-friendly practices? ◆ Are community services (like building toilets/ access to clean drinking water, etc., for the local community) provided as part of corporate social responsibility activities? <ul style="list-style-type: none"> ◆ Are formal sustainability management plans in place? ◆ Are progress towards sustainability goals measured and corrective actions taken? ◆ Do the PSS providers proactively consider their external impact while making decisions? 	<ul style="list-style-type: none"> ➢ achieving holistic improvement on the quality of life of all stakeholders and the local affected community. <ul style="list-style-type: none"> ➢ socially responsible behavior. ➢ adoption of environment-friendly practices. ➢ corporate social responsibility activities to positively impact the local community. ➢ formal sustainability management, measurement, adopting course corrections, and tracking impact.
Service Level		(...) service design	<input type="checkbox"/>	<ul style="list-style-type: none"> ◆ Is the long-term impact on the environmental, economic, and social sustainability considered while making decisions? <ul style="list-style-type: none"> ◆ Are customers of the PSS able to clearly understand the (un)sustainability along the whole value production chain? ◆ Are customers able to appreciate the need for responsible/ sustainable behavior by the supply system? 	<ul style="list-style-type: none"> ◆ Design or incorporate services (like training programs, communication platforms, tools, recognition, events, conferences, alliances etc.) that <ul style="list-style-type: none"> ➢ sensitize the stakeholders on social responsibility and environment-friendly practices. ➢ educate consumers about need for responsible/ sustainable behavior <ul style="list-style-type: none"> ➢ enable the customers to make informed consumption choices. ➢ aid in measurement of sustainability goals and progress towards it.
Agricultural Machine Characteristics		(...) product design	<input type="checkbox"/>		<p style="text-align: center;">Design the product to</p> <ul style="list-style-type: none"> • enable sustainable consumption. (AC is programmed to switch on at 24° C rather than 18° C/ an appliance with an eco-mode/ shows how much energy was consumed at the end of the operation. <ul style="list-style-type: none"> • help the customer in making informed consumption choices. • enable timely repair, customization, and responsible disposal.
4. Favor/ integrate weaker and marginalized strata				Priority: <input type="checkbox"/> High <input type="checkbox"/> Medium <input type="checkbox"/> Low <input type="checkbox"/> No	
System Level	Favor/ integrate weaker and marginalized strata	Favor/ integrate weaker and marginalized strata through system design	<input type="checkbox"/>	<ul style="list-style-type: none"> ◆ Are vulnerable people (like people with different degrees of ability and disability, minorities or socially disadvantaged groups, young or aged workers) supported and integrated or discriminated against and marginalized (as workforce/ community members)? How? <ul style="list-style-type: none"> ◆ Is the offering system accessible to people with lower income? ◆ Does the offering system lead to discrimination and marginalization of any group of people based on religion, gender, age, caste, etc.? <ul style="list-style-type: none"> ◆ Is gender-based discrimination (like opportunities, pay, workload, scheduling, benefits, etc.) present in the value chain? ◆ Is the value chain designed to be gender-neutral and gender-sensitive? 	<ul style="list-style-type: none"> ◆ Design the system to enable <ul style="list-style-type: none"> ➢ access of the PSS for all strata of the society. ➢ shared usage and/or exchange of goods and services to improve accessibility. <ul style="list-style-type: none"> ➢ financial access. ➢ gender-inclusive and gender-sensitive performance. ➢ non-discriminatory participation and consumption. ➢ empowerment of the weaker/ marginalized strata.
Service Level		(...) service design	<input type="checkbox"/>		<ul style="list-style-type: none"> ◆ Design or incorporate services (like training programs, communication platforms, tools, recognition, events, conferences, alliances etc.) that <ul style="list-style-type: none"> ➢ sensitize and involve all strata of the society without discrimination. ➢ identify and involve the marginalized and the weaker strata.

					<ul style="list-style-type: none"> ➤ improve financial/ knowledge access. ➤ enable unemployed people to earn a living (job/ entrepreneurship). ➤ diversify the offering to meet the needs and financial capabilities of all strata of the society. ➤ enable sharing, exchange and cost optimization through them.
Agricultural Machine Characteristics		(...) product design	<input type="checkbox"/>		<ul style="list-style-type: none"> ◆ Gender sensitive product design ◆ Design for accessibility ◆ Design for ease of learnability
5. Improve social cohesion					
System Level	Improve social cohesion	Improve social cohesion through system design	<input type="checkbox"/>	<ul style="list-style-type: none"> ◆ Does the PSS create or favor any kind of social conflicts due to: <ul style="list-style-type: none"> ➤ intra-gender, intra-culture, intra-generation exclusions in any form? ➤ discriminations in any form on the basis of gender, religion, culture, gender, age, income, etc.? 	<p>Priority: <input type="checkbox"/> High <input type="checkbox"/> Medium <input type="checkbox"/> Low <input type="checkbox"/> No</p> <ul style="list-style-type: none"> ◆ Design the system to stimulate <ul style="list-style-type: none"> ➤ identification of possible social conflicts. ➤ resolution of social conflicts. ➤ intra-gender, intra-culture, intra-generation cohesion and integration.
Service Level		(...) service design	<input type="checkbox"/>		<ul style="list-style-type: none"> ◆ Design or incorporate services (like training programs, communication platforms, tools, recognition, events, conferences, alliances etc.) that <ul style="list-style-type: none"> ➤ sensitize involved stakeholders/ value chain actors/ local community/ clients regarding intra-gender, intra-culture, intra-generation cohesion and integration. <ul style="list-style-type: none"> ➤ sensitize them on issues related to social integration. ➤ provide a platform for conflict resolution. ➤ promote sharing and mutual dependence to improve cohesion. ➤ promote co-working and co-design to improve cohesion.
		(...) product design			<ul style="list-style-type: none"> ◆ Gender sensitive product design ◆ Design for accessibility ◆ Design for ease of learnability
6. Empower/ valorize local resources					
System Level	Empower/ valorize local resources	Empower/ valorize local resources through system design	<input type="checkbox"/>	<ul style="list-style-type: none"> ◆ Does the current reference system/ PSS/ value chain <ul style="list-style-type: none"> ➤ impoverish local cultural values and identities? ➤ offer only one solution/ few variations for all regions and cultures? ➤ have a negative impact on social well-being of the local community? <ul style="list-style-type: none"> ➤ impoverish local economies? ➤ absorb local non-renewable resources? ➤ have an impact on indigenous knowledge? 	<p>Priority: <input type="checkbox"/> High <input type="checkbox"/> Medium <input type="checkbox"/> Low <input type="checkbox"/> No</p> <ul style="list-style-type: none"> ◆ Design the system and services to <ul style="list-style-type: none"> ➤ value, celebrate and empower local cultural values and identities. ➤ enrich local economy through opportunity generation. ➤ support local procurement of raw materials, manufacturing facilities, workforce, etc. ➤ promote and strengthen local enterprises/ businesses. <ul style="list-style-type: none"> ➤ regenerate/ enhance local natural resources. ➤ create solutions customized to local needs and capabilities.
Service Level		(...) service design	<input type="checkbox"/>		

			<ul style="list-style-type: none"> ➤ exploit indigenous knowledge without giving due acknowledgement and monetary returns to the community? ➤ use indigenous knowledge which in the given context might result into more sustainable practices? ➤ use/ support the production of locally adapted seed varieties, livestock breeds, traditional heirloom varieties, etc.? ➤ eliminate or reduce the use of locally adapted seed varieties, livestock breeds, traditional heirloom varieties, etc.? ➤ support local procurement of raw materials, manufacturing facilities, workforce, etc.? ➤ empower/ valorize local resources? ➤ negatively impact the local community's health and well-being by polluting or contaminating water, air and soils? ➤ positively impact the local community's health and well-being? 	<ul style="list-style-type: none"> ➤ acknowledge indigenous knowledge and compensate stakeholders for using it. <ul style="list-style-type: none"> ➤ learn from and use local sustainable practices. ➤ use/ support the production of locally adapted seed varieties, livestock breeds, traditional heirloom varieties, etc. <ul style="list-style-type: none"> ➤ positively impact the local community's health and well-being. ➤ collaborate and co-design with the local community/ economic actors to enhance local capacity for design and production of PSS. <ul style="list-style-type: none"> ➤ develop local service industry.
<p>Agricultural Machine Characteristics</p>		<p>(...) product design</p>	<p><input type="checkbox"/></p>	<ul style="list-style-type: none"> ♦ Can the product create new opportunities for the local people? <ul style="list-style-type: none"> ➤ materials ➤ skills and knowledge ➤ resources ➤ other capacities? ♦ Can the product use locally available: <ul style="list-style-type: none"> ➤ materials ➤ skills and knowledge ➤ resources ➤ other capacities?



6.4. D-SAM - A methodology for sustainability-oriented design of agricultural mechanization

This section presents the final SAM design framework, called as D-SAM, signifying Design for Sustainable Agricultural Mechanization. The methodology consists of five stages: 1. Strategic analysis; 2. Exploring opportunities; 3. Designing system concepts; 4. Product designing and engineering; 5. System designing, and engineering. The process (1.6) *Analyze sustainability and determine priorities for the design intervention concerning sustainability* (Stage 1 - Strategic analysis) and process (2.1) *Generating sustainability-oriented ideas* (Stage 2 - Exploring opportunities) can be performed simultaneously using G-SAM. Since G-SAM supports design for S.PSS, sustainable agricultural outcome and environment-friendly product design, some (sub-)processes from conceptual framework I are reduced. The changes are as follows:

1. Process (1.3) *Product Analysis* now has only one sub-process, *identification and analysis of existing products/ solutions*. The other two sub-processes, *analysis of existing products using ICS toolkit on the environmental dimension* and *defining the product design priorities* are conducted in process (1.6) *Analyze sustainability and determine priorities for the design intervention concerning sustainability* using G-SAM.
2. Process (1.2) *Generating sustainability-oriented ideas* uses G-SAM to generate product, service and system ideas with environmental, socio-ethical, and economic sustainability characteristics.
3. The PSS concepts generated in stage 3 and the final PSS concept generated as a result of stage 4 and 5 are evaluated using G-SAM.
4. Stage 4: *Product Designing and Engineering* now has only one process, (4.1) *Designing and Engineering the Product concept*. The second process, (4.2) *Environmental, socio-ethical, and economic assessment* is now conducted in process (5.2) *Environmental, socio-ethical, and economic assessment* where the product, service and the system are simultaneously evaluated using G-SAM.

[Figure 6.11](#) (next page) presents D-SAM stages and processes, highlighting the main contributions of the author for the thesis. [Table 6.8](#) presents the details of D-SAM's stages, processes, sub-processes, and tools along with the results of using each (sub-)process and tool.

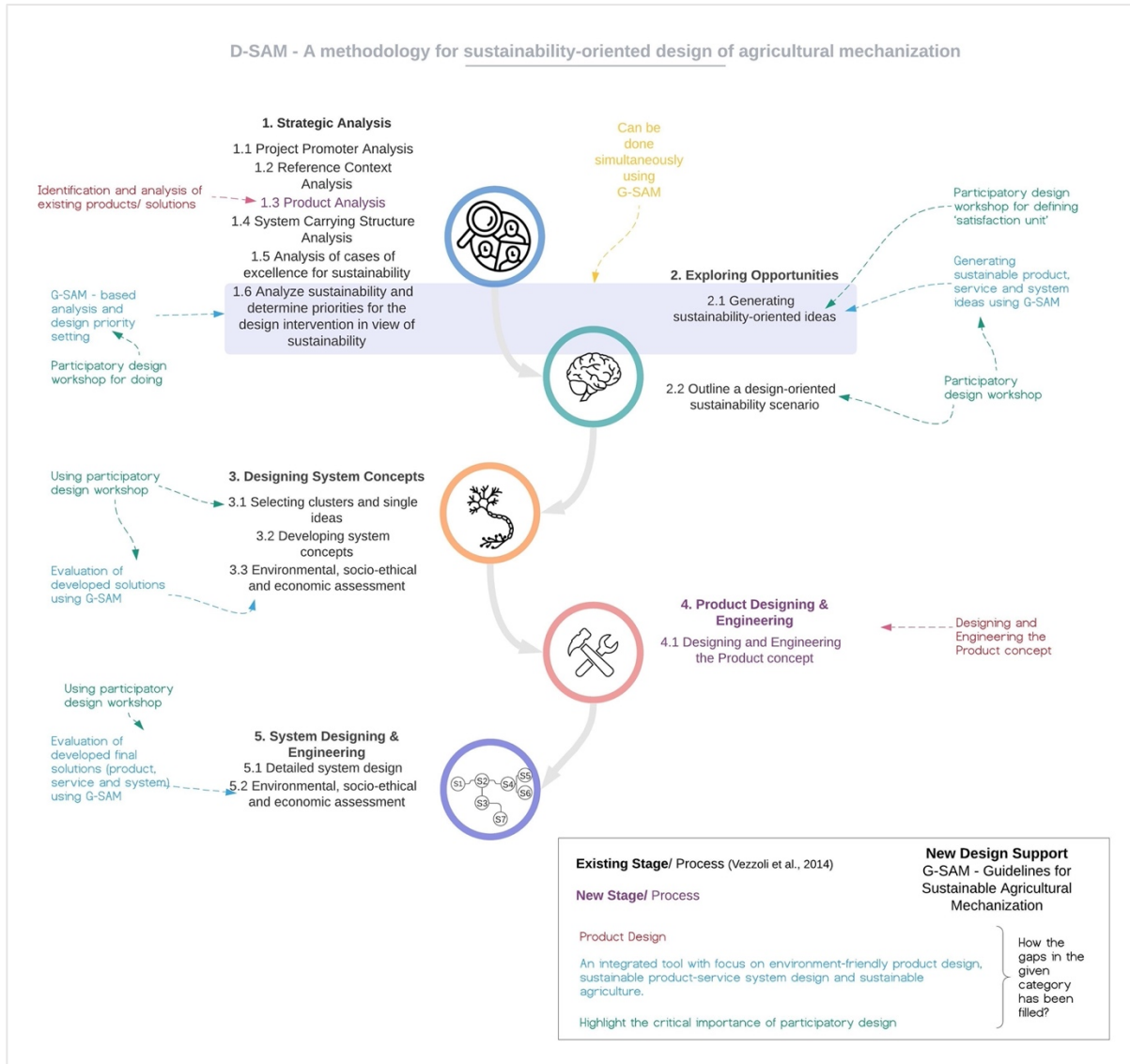

Figure 6.11. D-SAM - A methodology for sustainability-oriented design of agricultural mechanization

Table 6.8. SAM design methodology – SAM Framework

Note: * from MSDS; **bold** are from conceptual framework I, published at (Banerjee and Punekar, 2020); **bold italic** are modifications post the formulation of G-SAM; # are processes which can be conducted simultaneously using G-SAM.

Stage	Process	Sub-process	Result and (tools)
*1. Strategic Analysis	*(1.1) Project promoter analysis and definition of intervention context	*Design intervention's scope description	*Document detailing intervention scope and design brief
		*Analyze project promoter(s)	*Summary of project promoter analysis: mission, primary expertise, (SWOT), and value chain (System Map) analysis
	*(1.2) Reference context analysis	*Analyze the production and consumption system for the intended design intervention	Analysis of system actors & their interactions (System Map) and mapping the system's technology, culture, and regulatory dynamics
*Competitor analysis		*Identification of competitors, their offers, market segmentation, and competitive position for the proposed offering (Model 5 Porter Forces)	

		*Client or end-user analysis	*Expressed and latent needs analysis (Means-end analysis)
	(1.3) Product Analysis	Identify and analyze existing products/ solutions	Summary of existing products/ solutions, engineering, and manufacturing requirements and shortcomings
	* (1.4) System carrying structure analysis	*Analyze macro-trends	*Report on social, economic, and technological macro-trends and their influence on the reference context
	* (1.5) Analysis of cases of excellence for sustainability	*Identify and analyze cases of excellence	*Summary of cases of excellence analysis, describing: <ul style="list-style-type: none"> • Offer composition and interaction with the user (Interaction Map) • Actors who produce and deliver the offer (System Map) • Sustainability characteristics (<i>G-SAM</i>)
	* (1.6) Analyze sustainability and determine priorities for the design intervention concerning sustainability #	*Analyze existing context for environmental, socio-ethical, and economic sustainability	Analysis of sustainability performance of existing <i>product, services, and system</i> conducted through (participatory design workshops) using (<i>G-SAM</i>)
		*Define design priorities	*Design priorities for each dimension of sustainability through (participatory design workshops) using (<i>G-SAM</i>)
*2. Exploring Opportunities	*(2.1) Generating sustainability-oriented ideas #	*Define satisfaction unit	*Document detailing the satisfaction unit and sub-satisfactions, set using (participatory design workshops)
		*Generate sustainable product, service, and system ideas	*Environmental, socio-ethical, and economic sustainability-oriented ideas using (<i>G-SAM</i>)
	*(2.2) Outline a design-oriented sustainability scenario	* Define clusters and single ideas	*Description of idea clusters and single ideas.
		*Identify polarizing ideas and plot polarity diagrams	*(Polarity diagram) with polarized ideas, visions, and clusters of ideas.
		* Define visions	*(Audiovisual documents) visualizing concepts using (participatory design workshops)
*3. Designing System Concept	*(3.1) Selecting clusters and single ideas	*Select the most promising ideas and clusters	* Document explaining the selection of ideas and idea clusters, considering (economic and technological feasibility, and user-acceptability) through (participatory design Workshops). (Polarities diagrams, portfolio diagrams, and Go/ no go evaluation).
		*Define actor interactions in the new system	*Map of actors in the new system and the material, information, labor, and money flows amongst them (System Map)
	*(3.2) Developing system concepts	* Define the product and service offerings	*Summary of the main functions delivered to the user using (offering diagrams)
		*Narrate user interactions with the system and other actors for providing the offer	*Summary of the sequence of actor interactions involved in the production and delivery of the offer using (interaction table and interaction storyboard)

	* (3.3) Environmental, socio-ethical and economic assessment	*Assess the environmental, socio-ethical, and economic improvement potential of the concepts *Visualize the environmental, socio-ethical, and economic improvements	*Description and assessment of the improvement potential for every criterion of each dimension using (<i>G-SAM</i>) • *Environmental, socio-ethical, economic sustainability improvements using (radar diagrams) plotted with data from (<i>G-SAM</i>) *Visualization of the interactions that support sustainability improvements
4. Product Designing and Engineering	(4.1) Designing and Engineering the Product concept		Detailed product design with manufacturing drawings and bill of materials
*5. System Designing and Engineering	*(5.1) Detailed system design	*Detail the interactions between primary and secondary actors in the new system	*Detailed map of the principal and secondary actors and the material, information, labor, and money flows between them (system map)
		*Detail the products and services of the offering	*List of primary and secondary functions delivered to users (offering diagrams)
		*Detail the actor interactions during delivery of the offer	*Narration of sequence of interactions during the production and delivery of the offer (interaction table and interaction storyboard)
		*Detail actors' role, contribution, and motivations	*(Motivation matrix) showing each actor's contribution to the partnership, their expected benefits, and potential conflicts
		*Detail the material and non-material elements required for delivery of the offer (and defining who will design/produce/ deliver it	*Map indicating the elements required by the system and the role of the actors in designing, producing, and delivering it (Solution element brief)
(5.2) Environmental, socio-ethical, and economic assessment	*Describe the expected environmental, socio-ethical, and economic improvements due to the proposed system's implementation	*Description and assessment of sustainability improvement potential using (<i>G-SAM</i>)	
	Visualize the expected environmental, socio-ethical, and economic improvements	• *Plotting (radar diagrams) to represent the improvements (<i>G-SAM</i>) *Visualizations of interactions that produce the improvements.	

7. Evaluation and validation

This chapter answers research question 3, which enquires:

How effective is the proposed sustainability-oriented design support in use and operationalization during the design conceptualization phase of SAM for small farms of developing countries?

The sustainability-oriented design methodology, D-SAM, is a modification of an established methodology MSDS. The change in the stages and processes of MSDS for D-SAM includes the addition of product design focus and participatory design recommendation for both assessment and design. Hence, D-SAM was not the focus of the evaluation and validation process. Since G-SAM is a new set of assessment and design guidelines, its evaluation and validation were performed. To evaluate G-SAM, first, a set of evaluation criteria was determined. Next, the evaluation was conducted using two strategies. In strategy one, fifteen design students were divided into two groups with different problem statements and asked to design a SAM based S.PSS first without and then with G-SAM. A statistical analysis of the students' performance helped ascertain the effectiveness of G-SAM in analysis and design. The students also evaluated G-SAM for its effectiveness in use and operationalization during a SAM's design conceptualization phase. In strategy two, four Industrial Designers from China, two Ph.D. researchers from India (one from Mechanical Engineering and one from Design), and a Design professional from India (with background degrees in Mechanical Engineering and Design) used G-SAM. They used it in their past or running SAM design projects. Post using G-SAM, they evaluated its effectiveness in use and operationalization during the design conceptualization phase of SAM. G-SAM was, thus, applied in eight different project briefs from two developing countries. Consequently, the validity of G-SAM for the same class of problems was established. The following sections present the evaluation and validation process and results.

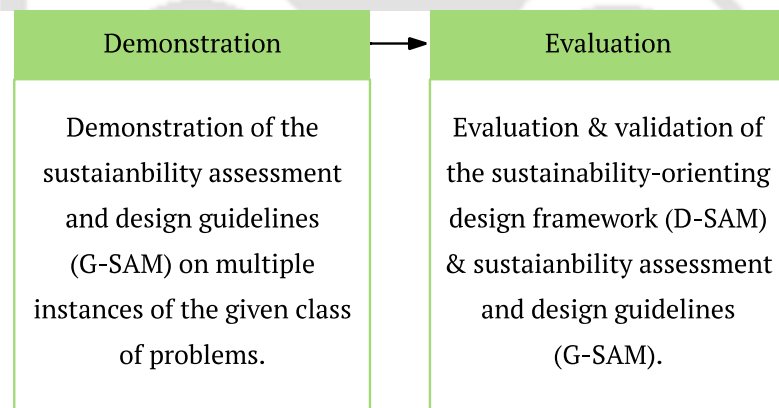

7.1. Evaluation criteria

[Table 7.1](#) presents the list of critical success factors that a sustainability-oriented assessment and design tool for SAM based S.PSS should possess. It combines the plan drawn by [de Mey et al. \(2011\)](#) and several other authors who have designed assessment and design supports for DfS in the context of S.PSS ([Vezzoli et al., 2014](#)) or agricultural practices ([Binder et al., 2010](#); [Binder et al., 2012](#); [De Ridder et al., 2010](#); [Schader et al., 2014](#)). The description of the critical success factors has been adapted to suit the specific needs of the DfS typology, i.e., SAM based S.PSS. The critical success factors for a sustainability-oriented design support should possess the following characteristics:

1. Compatibility ([de Mey et al., 2011](#)) - ²⁶It should be compatible with low levels of data, a typical characteristic of the design process's fuzzy front-end. Thus, it should use rapid sustainability assessment. It should aid in generating a large pool of design ideas, which can then be used by the designer to build various concepts by making informed trade-off decisions.
2. User-friendliness - It should be user-friendly in terms of understandability, ease of use, usability, and time requirement ([de Mey et al., 2011](#)). The designer should be able to adapt it to suit different design scenarios and types of data and resources available at hand. Also, it should cater to both expert and participatory design processes. ([Binder et al., 2010](#); [Binder et al., 2012](#); [Vezzoli et al., 2014](#)).
3. Data-availability ([de Mey et al., 2011](#)) – ²⁵It should make data available to cater to rapid sustainability assessment and design needs.
4. Complexity – The tool presenting the sustainability-oriented design guideline should be of optimal complexity for the given context ([de Mey et al., 2011](#)).
5. Transparency ([de Mey et al., 2011](#)) – This can be defined by answering the following question - Can the designer recognize the interdependencies between indicators? Can the designer recognize and make informed trade-offs? Can the designer identify the aspects that are not under the control of the PSS stakeholders but has more global connectivity? ([Binder et al., 2010](#); [Binder et al., 2012](#); [Vezzoli et al., 2014](#)). Does it bring greater transparency in design decisions? ([de Mey et al., 2011](#))
6. Data correctness - The correctness of the data. ([de Mey et al., 2011](#))
7. Communication aid - It should aid in communication between stakeholders ([de Mey et al., 2011](#)).
8. Organization of discussion sessions ([de Mey et al., 2011](#)) – It should aid in discussion between stakeholders. ²⁵It should support the designer in gathering field data, data from experts, and conducting participatory design sessions.
9. ²⁵Knowledge hybridization (degree of trans-disciplinarity) – It should aid the designer through knowledge hybridization by bringing in transdisciplinary perspective and knowledge.
10. Degree of systemic knowledge captured – It is defined in terms of sufficiency (as much complexity as necessary), parsimony (as much simplicity as possible), and indicator interaction. ([Binder et al., 2010](#))
11. Prioritize-ability of the targets – It should support context-appropriate prioritization of dimensions and criteria within them. ([Vezzoli et al., 2014](#))
12. Effectiveness of the tool - The extent to which the support is perceived as relevant to use and implement. ([de Mey et al., 2011](#))
13. Effectiveness of the target knowledge generated – It is needed in defining goals to better deal with problems. It is expressed in terms of output accuracy and tool function (like monitoring, communication, learning, and management function) ([De Ridder et al., 2010](#); [Schader et al., 2014](#)).

Apart from the characteristics mentioned above of the sustainability-oriented design support, it is also essential to measure the attitude ([de Mey et al., 2011](#)) and knowledge of the stakeholders involved in the design and development process towards sustainability. Assessment of attitude shows the dedication level of the stakeholders towards operationalizing sustainability. Sustainability knowledge assessment is essential since G-SAM uses qualitative assessment. For a qualitative assessment, knowledge and expertise in the domain improves assessment performance. Attitude can be accessed through questions on the values and beliefs of the stakeholders. For knowledge level assessment, past work and experiences can be assessed.

²⁶ Adaptation of the description of the critical success factor to suit the specific needs of the DfS typology, i.e., G-SAM based SPSS.

Table 7.1. Critical success factors for the implementation of integrated sustainability assessment tools adapted from [de Mey et al. \(2011\)](#) and additions from other authors who have designed assessment and design supports for DfS in the context of S.PSS.

([de Mey et al., 2011](#))

* ([Binder et al., 2010](#); [Binder et al., 2012](#); [Vezzoli et al., 2014](#))

^ ([Binder et al., 2010](#))

\$ ([Vezzoli et al., 2014](#))

~ ([De Ridder et al., 2010](#); [Schader et al., 2014](#))

+ Additions from the author based on the G-SAM features

SN	Critical Success Factor	Description
1	# Attitude towards sustainability	Values and beliefs of (+ stakeholders involved in the design and development) regarding sustainability.
2	+ Knowledge of sustainability	Level of sustainability knowledge and experience of stakeholders involved in the design and development process.
3	# Compatibility	+ At the fuzzy front-end of design, data availability is low. Also, quick decisions regarding design alternatives need to be made. Hence the design support should be compatible with little data, rapid sustainability assessment, and aid in generating a large pool of design ideas.
4	# User-friendliness	# This is defined in terms of (1) understandability of the tool for the designer, (2) ease of using it, (3) usability, (4) time requirement, and (5) * flexibility and adaptability to different design scenarios, data type and availability, resource type and availability, to expert and participatory approach.
5	# Data availability	Availability of data necessary for (+ rapid sustainability assessment and design).
6	# Complexity	The degree of complexity of the tool.
7	# Transparency	* Can the designer recognize the interdependencies between indicators? * Can the designer recognize and make informed trade-offs? * Can the designer identify the aspects that are not under the control of the PSS stakeholders but has more global connectivity? # Does it bring greater transparency in design decisions?
8	# Data correctness	The correctness of the data.
9	# Communication aid	Does it aid in communication between stakeholders?
10	# Organization of discussion sessions	# Does it aid in discussion between stakeholders? + Does it support the designer in gathering field data, data from experts, and conducting participatory design sessions?
11	+ Knowledge hybridization (degree of trans-disciplinarity)	Aiding the designer through knowledge hybridization by bringing in transdisciplinary perspective and knowledge.
12	^ Degree of systemic knowledge captured	Defined in terms of sufficiency (as much complexity as necessary), parsimony (as much simplicity as possible), indicator interaction.
13	\$ Prioritize-ability of the targets	DfS has to deal with context-appropriate prioritization of dimensions and criteria.
14	# Effectiveness of tool	The extent to which the tool is perceived as being relevant to use and implement.

15	~ Effectiveness of target knowledge generated	Needed to define goals to better deal with problems and expressed in terms of output accuracy and tool function (like monitoring, communication, learning, and management function).
----	---	--

7.2. Evaluation and validation methodology

The evaluation and validation were conducted with the following two strategies:

7.2.1. Strategy 1

The aim here was to statistically evaluate the effectiveness of G-SAM in enhancing assessment and ideation outcome. Thus, fifteen design students were divided into two groups with different problem statements and asked to design a SAM based S.PSS first without and then with G-SAM. A statistical analysis of the students' performance helped ascertain the effectiveness of G-SAM in analysis and design. The students also evaluated G-SAM for its effectiveness in use and operationalization during a SAM's design conceptualization phase.

[Björklund \(2013\)](#) reports significant differences between expert designers' mental model versus that of novice (student) designers' mental model in the context of "*defining and structuring wicked design problems*." The author studied the differences between expert and novice designers based on information needs, problem structuring, process selection, and presentation of the problem. Experts demonstrated "*superior extent, depth, and level of detail, accommodating more interconnections and being more geared toward action*." For strategy 1, student designers were selected over experts because:

- ◆ It is assumed that if students can see a larger number of interconnections and their capability to define and structure wicked design problems improve, so will be that for experts.
- ◆ Since a SAM design project is time-consuming and resource-intensive, assessing the same with experts in numbers for statistical analysis was not practicable.

Fifteen student designers from the Department of Design at IIT Guwahati participated in the research during their elective course on *Product Detailing*. The students were from Ph.D. 1st year, 4th-year Bachelor of Design, and 2nd-year Master of Design. All students (except the Ph.D. student), being in the final year of undergraduate and postgraduate studies, were well equipped with basic product design knowledge and skills. The 1st year Ph.D. student had just completed her Master's in Design and was similarly equipped with basic product design knowledge and skills. All involved undergraduate students had also done a project-based *system design* course, and one of them had done a project-based *system design for sustainability* course before this course.

The students designed the SAM based S.PSS in two phases. In phase 1, the students were given a lecture on sustainability, DfS, and sustainability needs in agriculture. The students were not provided with any DfS support. They were free to use the internet or any other source of information. After the introductory workshop, the students analyzed and ideated in groups to discuss possible strategic ways to approach DfS. The discussions were recorded and analyzed to understand the students' mental model to approach DfS when provided with no design supports. Next, the students individually conducted an analysis and design ideation and submitted a report for the same. In the second phase of the experiment, the students were provided with G-SAM and instructed to conduct an analysis and ideation process and submit a report. They were again free to use the internet or any other source of information here too. The analysis and ideation reports were evaluated by

- ◆ counting the number of CF or DC identified as applicable for the problem statement in hand,

- ♦ counting the number of CF or DC against which assessment was done, or design ideas were generated (total number and correct ones), and
- ♦ computing the percentage of factual errors or misunderstandings per the number of assessments done or design ideas suggested.

Since the students had time and knowledge constraints, they could not ideate (or analyze) on many CF and DC. Hence, we asked them to mark all the CF and DC that they think are applicable. The process also helped us identify if design support helped them identify a more significant number of applicable CF and DC compared to no guideline scenario. The assumption here is, if students can identify a more significant number of applicable CF and DC, they will be able to perform analysis and ideation at a greater depth. This will imply a strengthening of the analysis and design process. On the other hand, computing the percentage of factual errors or misunderstandings per the number of assessments done or design ideas suggested with and without guidelines helped us understand if guidelines can quickly improve novice designers' knowledge levels in the context of cross-disciplinary and transdisciplinary wicked problems.

Post the analysis and ideation process, the students evaluated G-SAM. We created the evaluation questionnaire following the evaluation criteria presented in [Table 7.1](#). [Appendix 8](#) presents the strategy 1 evaluation questionnaire and results.

Problem context provided

Many north-eastern states of India are geo-climatically very suitable for growing ginger and turmeric. The hilly regions of Assam and Meghalaya, along with Assam's plains, are the focus areas for the project. Ginger and turmeric are two emerging cash crops of the region, which can bring considerable profits to the farmers. Since the farms of Assam and Meghalaya are smaller in size than the farms of southern India, where most ginger and turmeric production of the country happens, the potential for context-appropriate mechanization is high. The context demands on-farm processing of the produce so that the farmer can get higher returns on investment. The farms are located far from each other or the main city centers. Thus, carrying the produce to the nearest factory implies added transportation costs for the farmers. Since the production scale is low (due to the small farm size), economies of scale cannot be achieved if we try to move the fresh, unprocessed produce to centralized processing units. Hence, on-farm and on-demand processing make their case.

The PSS design scenario

Assume the ginger/ turmeric washing machine (problem statement 1) or the turmeric steamer (problem statement 2) works as a PSS offering. A particular LSP will buy the washing machine or the steamer. A farmer can contact an LSP and schedule the processing of his produce. The LSP will load the machines on a tempo (which can be either owned or hired by the LSP) and bring them to the farm. The machines can use the water available at the farm. For energy, the student could select an appropriate source. LSP also brings the laborers required for accomplishing the job. The farmer pays the LSP on an hourly basis.

Problem statement 1 (WM)

Design an on-farm ginger/ turmeric washer that can be mounted on a tempo and taken to the farm for operation. It should be suitable for farm sizes and produce levels of Assam and Meghalaya.

Problem statement 2 (TS)

Design an on-farm turmeric steamer, which can be mounted on a tempo and taken to the farm for operation. It should be suitable for farm sizes and produce levels of Assam and Meghalaya.

Statistical Analysis Methodology

We analyzed the variable counts from the analysis and ideation reports using two statistical methods: Independent-Samples T-Test and Paired-Samples T-Test. The Independent-Samples T-Test compares the differences between the means of the two groups (WM and TS) with different problem statements to check if the complexity levels of both the problem statements were similar or not for the students, both before and after the treatment, i.e., the introduction of G-SAM for designing AM. The nine dependent variables for this test are:

1. Number of CF/ DC on the environmental dimension identified as applicable
2. Number of CF/ DC on the economic dimension identified as applicable
3. Number of CF/ DC on the social dimension identified as applicable
4. Number of correct assessments done/ design ideas suggested on the environmental dimension
5. Number of correct assessments done/ design ideas suggested on the economic dimension
6. Number of correct assessments done/ design ideas suggested on the social dimension
7. Percentage of factual errors/ misunderstandings per number of assessments done/ design ideas suggested on the environmental dimension
8. Percentage of factual errors/ misunderstandings per number of assessments done/ design ideas suggested on the economic dimension
9. Percentage of factual errors/ misunderstandings per number of assessments done/ design ideas suggested on the social dimension

One of the sample hypotheses is:

H0: $\mu_{\text{WM-Number of CF/ DC on the environmental dimension identified as applicable}} = \mu_{\text{TS-Number of CF/ DC on the environmental dimension identified as applicable}}$

H1: $\mu_{\text{WM-Number of CF/ DC on the environmental dimension identified as applicable}} \neq \mu_{\text{TS-Number of CF/ DC on the environmental dimension identified as applicable}}$

where

$\mu_{\text{WM-Number of CF/ DC on the environmental dimension identified as applicable}}$

$\mu_{\text{TS-Number of CF/ DC on the environmental dimension identified as applicable}}$

are the population means for the WM and TS groups, respectively.

We drew a similar hypothesis for all the other dependent variables studied.

The Paired Samples T-Test compares the differences between the means of the same group of participants before and after the treatment, i.e., G-SAM's introduction for designing AM (WM and TS). This helps to identify if the introduction of G-SAM significantly improved the analysis and ideation and reduced the errors and misunderstandings. The study results are evaluated in three analyses, one with all data combined irrespective of problem statement group, two for the WM group, and three for the TS group. We used the same set of nine dependent variables, as mentioned for the Independent-Samples T-Test. One of the Sample hypotheses is stated as below:

H0: $\mu_{\text{Number of CF/ DC on the environmental dimension identified as applicable in phase 1}} = \mu_{\text{Number of CF/ DC on the environmental dimension identified as applicable in phase 2}}$

H1: $\mu_{\text{Number of CF/DC on the environmental dimension identified as applicable in phase 1}} \neq \mu_{\text{Number of CF/DC on the environmental dimension identified as applicable in phase 2}}$

where

$\mu_{\text{Number of CF/DC on the environmental dimension identified as applicable in phase 1}}$

$\mu_{\text{Number of CF/DC on the environmental dimension identified as applicable in phase 2}}$

are the population means for phase 1 (without G-SAM) and 2 (with G-SAM), respectively.

We drew a similar hypothesis for all the other dependent variables studied.

7.2.2. Strategy 2

The primary aim here was to test the applicability of G-SAM to the problem class, i.e., SAM for small farms of developing countries. The secondary aim was to qualitatively assess the challenges faced by professionals while using and operationalizing G-SAM. The participants consisted of:

- ♦ Three Industrial Designers from China with undergraduate and postgraduate degrees in Industrial Design.
- ♦ One Industrial Designer from China with Industrial Design undergraduate degree and Service Design postgraduate degree.
- ♦ One Ph.D. researcher from India with Mechanical Engineering undergraduate and postgraduate degree. He is currently pursuing a Ph.D. in Centre for Rural Technology in IIT Guwahati.
- ♦ One Ph.D. researcher from India with an undergraduate and postgraduate degree in Agricultural Engineering and Farm Machinery, respectively. He is currently pursuing a Ph.D. in the Department of Design at IIT Guwahati.
- ♦ One Design professional from India with an undergraduate degree in Mechanical Engineering, a postgraduate degree in Design, with more than five years of industry experience in designing machinery and pursuing a Ph.D. in Design.

The participants used G-SAM on their past or running SAM design projects. The project briefs are as follows:

1. Design an electric autopilot tractor to reduce human resources in agricultural work and improve farming efficiency. (context China, past project)
2. Design an uncrewed aerial vehicle to fertilize crops to reduce the harm to humans during fertilization. (context China, past project)
3. Design a modular potato harvester with different functions and price to suit different farmers' needs and contexts. (context China, past project)
4. Design a tool and technique for harvesting water chestnut crops to reduce the drudgery of farmers. (context India, running project)
5. Design of a ginger/ turmeric harvester for North-east India. (context India, running project)
6. Design a single bed micro-tiller. (context India, past project)

Post using G-SAM, they evaluated its effectiveness in use and operationalization during the design conceptualization phase of SAM. The participant details, evaluation questionnaire and responses are presented in [Appendix 9](#). Thus, G-SAM was evaluated and validated through eight different SAM problem statements and two developing country contexts.

7.3. Results and analysis

7.3.1. Students approach to DfS without any design supports

After the students were introduced to sustainability, DfS, and sustainability needs in agriculture, they initiated a group brainstorming session. In the absence of any guideline, both the groups came up with slightly different approaches to tackle the DfS challenge. The WM group first listed down all the features they thought should be part of their AM-based PSS. Then they segregated those features into the three dimensions of sustainability (Figure 7.1). After that, they conceptualized various design solutions and evaluated them based on technical feasibility or effectivity in performing the washing task and sustainability. This group also had the student who had already done a course on *System Design for Sustainability*. However, she did not bring the design supports that she learned during the course for adaption to the given context.

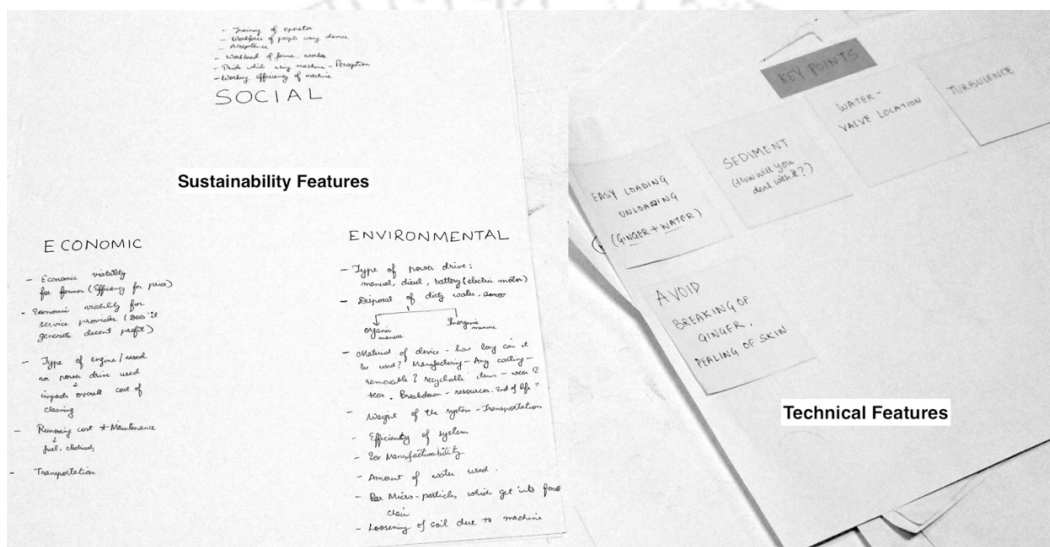

Figure 7.1. WM group's feature segregation into three dimensions of sustainability.

The TS group, on the other hand, created some design ideas. Then, they identified the design features that those ideas were able to fulfill and the sustainability dimension into which those could be categorized. They rated each design idea then on a scale of -1 (negative impact), 0 (not present), and 1 (positive impact) on each dimension (Figure 7.2).

Next, while performing the analysis and design task individually, all students followed a similar approach but had more individual preferences in choosing, rejecting, and prioritizing features for achieving DfS. In the group, choosing, rejecting, and prioritizing features had to be achieved through debate and mutual agreement. Thus, the typical behavior seen amongst the students was the tendency to prioritize and make trade-off decisions while trying to conduct DfS both in a group and individually. They could quickly grasp the systemic nature of DfS and the fact that they have to do a balancing act between various features to obtain a more sustainable solution than the current scenario.

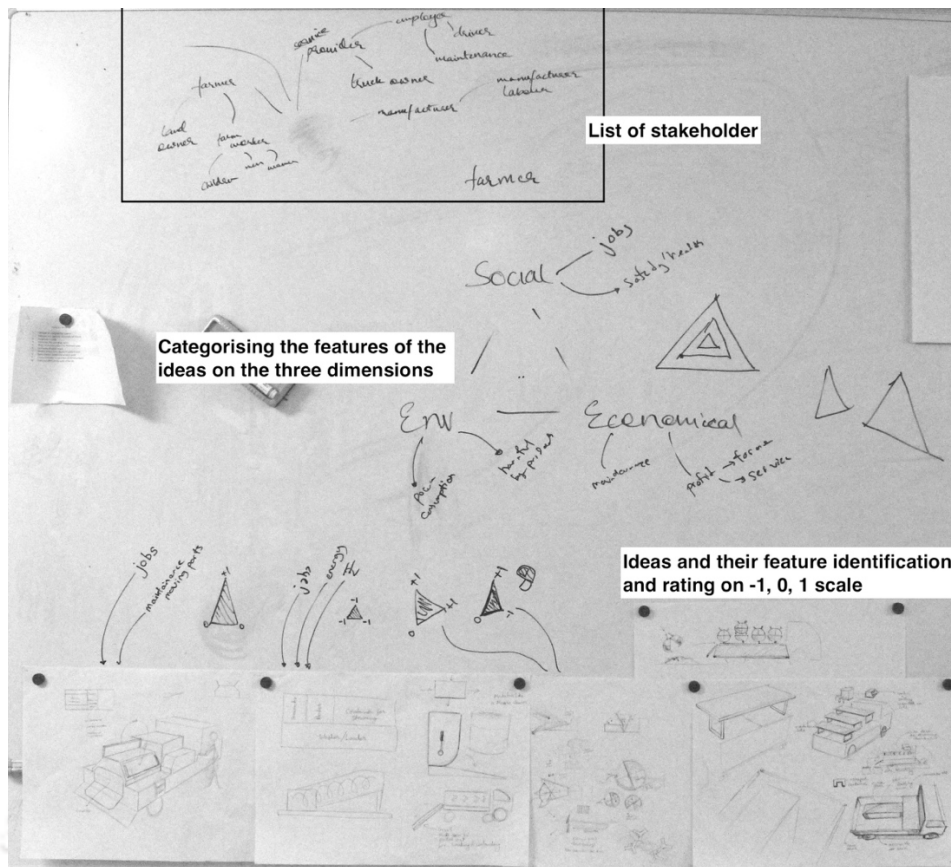

Figure 7.2. TS groups' rating method categorizes design ideas on the degree of fulfillment of sustainability criteria on each dimension.

7.3.2. Statistical Analysis - Comparing students' approach to DfS without and with G-SAM

Upon introduction of G-SAM, the depth of analysis and width of ideation amongst all students went up. We observed that students used G-SAM in slightly different ways from one another. For example, although all students analyzed in the sequence presented in G-SAM, not all students decided to start ideation from the environmental dimension and then proceed to economic and social. The students who used a different sequence mentioned that post-analysis, they thought a particular dimension had a higher priority than others and hence their preference for the sequence. Some students combined two or three CF/ DC to ideate. The Masters' students had not been introduced to system design during their coursework before this assignment. As a result, some of them showed a lack of understanding of the terms like system level, service level, and PSS. The undergraduate students had been introduced to the concept of system design before the assignment. However, one of them stated the terms (system level, service level, and PSS) as confusing. The other types of misunderstandings commonly involved were technical terms. They were interpreted with common-sense meanings. The students were allowed to use the internet for the assignment, but some still did not look up the terms' definitions. The tendency to design based on common sense and factually wrong notions reduced with G-SAM but did not go to zero.

To compare the change in students' approach to DfS, we compared the individual analysis and ideation report submitted by the students without and with design support. We counted the number of CF/ DC identified as applicable and the number of correct assessments done/ design ideas suggested. We also computed the percentage of factual errors/ misunderstandings per the number of assessments done/ design ideas suggested. [Table 7.2](#) below summarizes the same for both problem statements and phases of the experiment, segregated on sustainability's three dimensions. The table shows a three- or four-fold

increase in the average <number of CF/ DC identified as applicable (a)> and average <number of correct assessments done/ design ideas suggested (b)> across dimensions and both problem statements due to the usage of the G-SAM. Also, it shows a reduction in the average <percentage of factual errors/ misunderstandings per the number of assessments done/ design ideas suggested (c)>.

Table 7.2. Counts of the variables from the analysis and ideation report for both problem statements and phases of the experiment.

Variable (denoted as)	WM		TS		Dimension
	Phase 1	Phase 2	Phase 1	Phase 2	
Average <number of CF/ DC identified as applicable (a)>	4	12	3	12	Environmental
	3	9	1	6	Economic
	2	6	2	6	Social
Average <number of correct assessments done/ design ideas suggested (b)>	4	15	4	12	Environmental
	3	11	4	7	Economic
	2	8	4	8	Social
Average <percentage of factual errors/ misunderstandings per the number of assessments done/ design ideas suggested (c)>	21	8	14	7	Environmental
	29	8	0	0	Economic
	15	8	11	0	Social

Next, a statistical analysis was conducted and is summarized in [Table 7.3](#), [Table 7.4](#), [Table 7.5](#), and [Table 7.6](#) below. [Table 7.3](#) below summarizes the results of an Independent-Samples T-Test comparing the differences between the means for the two groups with different problem statements (WM and TS). It shows no significant difference between the means of the variables a, b, and c on the environmental and social dimensions in phases 1 and 2. On the economic dimension, there is no significant difference between the means of the variables a and b for the two groups in phase 1 and 2. Also, there is no significant difference between the means of the variable c for the two groups on the economic dimension in phase 2. However, there is a significant difference between the means of the variable c for the two groups on the economic dimension in phase 1. Thus, we can conclude that both the problem statements were similar in terms of complexity in the three dimensions for the students involved without any guideline involvement. Also, the introduction of G-SAM kept the complexity levels similar for both groups. However, the difference between the groups regarding factual errors and misunderstandings cannot be attributed to a specific cause for the without guideline context for the economic dimension. The mean and standard deviation value of the variable c for the TS group remains zero for both phase 1 and 2. So it can be attributed to either the group members or the problem statement characteristics.

Table 7.3. Results of the Independent-Samples T-Test.

Variable (Name)	Phase 1			Phase 2			Dimension
	WM	TS	Sig.	WM	TS	Sig.	
Number of CF/ DC identified as applicable (a)	M = 4.50, SD = 2.07	M = 2.86, SD = 2.19	t(13) = 1.492, p = 0.160	M = 12.13, SD = 2.75	M = 11.86, SD = 4.10	t(13) = 0.151, p = 0.883	Environmental
	M = 2.75, SD = 1.49	M = 1.43, SD = 0.98	t(13) = 1.999, p = 0.067	M = 8.38, SD = 3.85	M = 6.43, SD = 2.99	t(13) = 1.080, p = 0.300	Economic
	M = 3.25, SD = 2.05	M = 1.86, SD = 0.69	t(7) = 1.806, p = 0.105	M = 6.25, SD = 1.83	M = 5.71, SD = 1.98	t(13) = 0.545, p = 0.595	Social
Number of correct assessments done/ design ideas suggested (b)	M = 4.13, SD = 3.56	M = 4.00, SD = 3.46	t(13) = 0.069, p = 0.946	M = 14.75, SD = 6.82	M = 12.29, SD = 7.34	t(13) = 0.674, p = 0.512	Environmental
	M = 2.63, SD = 3.29	M = 2.71, SD = 2.22	t(13) = -0.061, p = 0.953	M = 10.88, SD = 5.89	M = 6.86, SD = 2.61	t(13) = 1.662, p = 0.120	Economic

Variable (Name)	Phase 1			Phase 2			Dimension
	WM	TS	Sig.	WM	TS	Sig.	
	M = 2.50, SD = 1.93	M = 2.71, SD = 1.98	t(13) = -0.212, p = 0.835	M = 7.75, SD = 5.23	M = 7.57, SD = 4.04	t(13) = 0.073, p = 0.943	Social
Percentage of factual errors/ misunderstandings per number of assessments done/ design ideas suggested (c)	M = 23.88, SD = 28.64	M = 14.71, SD = 20.30	t(13) = 0.704, p = 0.494	M = 8.00, SD = 13.02	M = 6.29, SD = 11.35	t(13) = 0.270, p = 0.792	Environmental
	M = 30.63, SD = 34.89	M = 0.00, SD = 0.00	t(7) = 2.483, p = 0.042	M = 7.13, SD = 11.15	M = 0.00, SD = 0.00	t(7) = 1.807, p = 0.114	Economic
	M = 15.00, SD = 22.68	M = 21.43, SD = 39.34	t(13) = -0.395, p = 0.700	M = 17.50, SD = 34.87	M = 0.00, SD = 0.00	t(7) = 1.419, p = 0.199	Social

Table 7.4, Table 7.5 and Table 7.6 show the results of the Paired Samples T-Test comparing the differences between the means for the participants before and after the treatment (the introduction of G-SAM for designing AM), irrespective of the problem statement group, for the problem statement group WM and TS, respectively. There was a significant difference in the means for the variable *a* and *b* on all three dimensions but no significant difference for the variable *c*. Thus, we can conclude that G-SAM's introduction significantly improved the number of CF/ DC identified as applicable, and the number of correct assessments done and design ideas suggested by the students. Although the percentage of factual errors or misunderstandings per total number of assessments done and design ideas suggested reduced (Table 7.2), we cannot claim the same at a 95% confidence interval. Also, there is no correlation between the means of phase 1 and 2 for the variable *c*. Hence, we conclude that the percentage of factual errors or misunderstandings per total number of assessments done and design ideas suggested is not related to the problem statement characteristics.

Table 7.4. Results of the Paired-Samples T-Test (With all the data combined irrespective of problem statement group).

Variable	Phase 1	Phase 2	Sig.	Correlation	Dimension
Number of CF/ DC identified as applicable (a)	M = 3.73, SD = 2.22	M = 12.00, SD = 3.32	t(14) = -8.171, p = 0.0001	–	Environmental
	M = 2.13, SD = 1.41	M = 7.47, SD = 3.50	t(14) = -5.905, p = 0.0001	–	Economic
	M = 2.60, SD = 1.68	M = 6.00, SD = 1.85	t(14) = -4.795, p = 0.0001	–	Social
Number of correct assessments done/ design ideas suggested (b)	M = 4.07, SD = 3.39	M = 13.60, SD = 6.93	t(14) = -5.079, p = 0.0001	–	Environmental
	M = 2.67, SD = 2.74	M = 9.00, SD = 4.96	t(14) = -4.559, p = 0.0001	–	Economic
	M = 2.60, SD = 1.88	M = 7.67, SD = 4.55	t(14) = -3.596, p = 0.003	–	Social
Percentage of factual errors/ misunderstandings per number of assessments done/ design ideas suggested (c)	M = 19.60, SD = 24.68	M = 7.20, SD = 11.86	t(14) = 2.046, p = 0.060	r = 0.340, p = 0.215	Environmental
	M = 16.33, SD = 29.31	M = 3.80, SD = 8.70	t(14) = 1.662, p = 0.119	r = 0.159, p = 0.571	Economic
	M = 18.00, SD = 30.52	M = 9.33, SD = 26.26	t(14) = 0.815, p = 0.429	r = -0.046, p = 0.870	Social

Table 7.5. Results of the Paired-Samples T-Test (For the problem statement group WM).

Variable	Phase 1	Phase 2	Sig.	Correlation	Dimension
Number of CF/ DC identified as applicable (a)	M = 4.50, SD = 2.07	M = 12.13, SD = 2.75	t(7) = -9.036, p = 0.0001		Environmental

Variable	Phase 1	Phase 2	Sig.	Correlation	Dimension
	M = 2.75, SD = 1.49	M = 8.38, SD = 3.85	t(7) = -4.652, p = 0.002		Economic
	M = 3.25, SD = 2.05	M = 6.25, SD = 1.83	t(7) = -2.646, p = 0.033		Social
Number of correct assessments done/ design ideas suggested (b)	M = 4.13, SD = 3.56	M = 14.75, SD = 6.82	t(7) = -4.313, p = 0.004		Environmental
	M = 2.63, SD = 3.29	M = 10.88, SD = 5.89	t(7) = -3.832, p = 0.006		Economic
	M = 2.50, SD = 1.93	M = 7.75, SD = 5.23	t(7) = -2.616, p = 0.035		Social
Percentage of factual errors/ misunderstandings per number of assessments done/ design ideas suggested (c)	M = 23.88, SD = 28.64	M = 8.00, SD = 13.02	t(7) = 1.487, p = 0.181	r = 0.104, p = 0.806	Environmental
	M = 30.63, SD = 34.89	M = 7.13, SD = 11.15	t(7) = 1.769, p = 0.120	r = -0.090, p = 0.832	Economic
	M = 15.00, SD = 22.68	M = 17.50, SD = 34.87	t(7) = -0.169, p = 0.871	r = -0.018, p = 0.966	Social

Table 7.6. Results of the Paired-Samples T-Test (For the problem statement group TS).

Variable	Phase 1	Phase 2	Sig.	Correlation	Dimension
Number of CF/ DC identified as applicable (a)	M = 2.86, SD = 2.19	M = 11.86, SD = 4.10	t(6) = -4.500, p = 0.004		Environmental
	M = 1.43, SD = 0.98	M = 6.43, SD = 2.99	t(6) = -3.454, p = 0.014		Economic
	M = 1.86, SD = 0.69	M = 5.71, SD = 1.98	t(6) = -4.500, p = 0.004		Social
Number of correct assessments done/ design ideas suggested (b)	M = 4.00, SD = 3.46	M = 12.29, SD = 7.34	t(6) = -2.757, p = 0.033		Environmental
	M = 2.71, SD = 2.22	M = 6.86, SD = 2.61	t(6) = -2.950, p = 0.026		Economic
	M = 2.71, SD = 1.98	M = 7.57, SD = 4.04	t(6) = -2.279, p = 0.063		Social
Percentage of factual errors/ misunderstandings per number of assessments done/ design ideas suggested (c)	M = 14.71, SD = 20.30	M = 6.29, SD = 11.35	t(6) = 1.631, p = 0.154	r = 0.768, p = 0.044	Environmental
	-	-	-	-	Economic
	M = 21.43, SD = 39.34	M = 0.00, SD = 0.00	t(6) = 1.441, p = 0.200	-	Social

7.3.3. Qualitative Analysis – Evaluation of G-SAM by students and professionals

The qualitative evaluation of G-SAM, as provided by all participants, is summarized below. The summaries on the fifteen critical success criteria have been presented in groups to convey the assessment to the fullest without repeating feedback.

7.3.3.1. Attitude and knowledge of model users toward sustainability

Twelve out of fifteen students said they would use or are using sustainability principles in their thesis work. The response data shows a definite intent to use sustainability principles in their work. However, the feedback also indicates that their knowledge on how to use it is not based on facts and principles but more on common sense and surface-level knowledge or misunderstandings regarding the concept of sustainability. For example, one student quoted that as he plans to use recyclable materials, he uses sustainability principles in the project. Just using recyclable materials cannot ensure

sustainability if the product, for example, is not designed for disassembly or without a supporting PSS to collect it for recycling. For the three students who said no to the question regarding if they will use or are using the principles of sustainability in their thesis work, one said so because of a lack of knowledge regarding the concept of sustainability in her subject domain. The second said because he thought that it was of secondary importance to his project. The third said that she did not use it yet but was open to using it in the future.

Thus, overall, we received a positive response towards the idea and the need for DfS amongst the students. However, as most of them were using DfS not based on facts and principles but more on common-sense and surface-level knowledge or misunderstandings regarding the concept of sustainability, it is deemed essential to create design supports to help them in DfS. The data from phase 1 and 2 show that the number of misunderstandings/ factual errors reduced with G-SAM use.

The second group, as compared to the students, had substantial knowledge and inclination towards DfS. They also viewed sustainability as a system property and at the confluence of three dimensions. They had consciously considered it during their project execution, even before getting introduced to G-SAM. For example, one of the participants quoted, *"The basic principles of sustainability in my project are optimization of site selection and procedure, minimization of energy consumption, use of low-cost and easily available manufacturing products, and optimization of operational and maintenance practices."* Nevertheless, the participants found G-SAM very useful as it made visible an extensive array of sustainability aspects. Thus, their design process was more structured and streamlined.

7.3.3.2. Compatibility

All students reported that they found G-SAM very helpful in analyzing possible sustainability issues and ideating sustainable solutions. The design support is compatible with little data (which is characteristics at the fuzzy front end of design), rapid sustainability assessment, and aid in generating a large pool of design ideas. G-SAM was reported to be useful by both problem statement groups. Amongst the second group of participants, everyone except one found G-SAM compatible with their projects. The participant who did not find G-SAM compatible stated, *"I will find little difficulty in relating my topic area through G-SAM as cultivation of water chestnut is completely different from other crops, but I believe it can be helpful for other land crops."* Hence, evaluation data shows G-SAM's possible use over a broad context of SAM design. However, further enhancement of G-SAM guidelines considering alternate farming techniques like hydroponics or aquaculture can be undertaken in the future.

7.3.3.3. User-friendliness, Complexity, and Effectiveness of tool

The students found G-SAM was useful in opening their minds to the various aspects of sustainability, broadened their perspective of the scope of DfS, helped them see the systemic nature of the problem, and thus the need for systems thinking. We did not conduct a class to explain G-SAM to students. Instead, the guideline was given to them with minimal instructions, as shown in (Chapter 6, [Figure 6.9](#)). All students could easily follow the same and start using G-SAM. On ease of use, eight students rated G-SAM as "Just Right," five as "Difficult," while two as "Easy." Fourteen students rated the G-SAM's Rapid Assessment Checklist as useful for gathering field data for an AM design project. Thirteen students evaluated the G-SAM's Design Guideline as helpful to conduct a participatory design session for a farming machinery design project. All the students rated G-SAM either helpful (5 out of 15) or very helpful (10 out of 15) on relevance to use and implement rather than the "no design support" scenario. It was regarded as very helpful because designing without G-SAM was difficult as fewer pointers were to think about. They were not aware of many aspects given the transdisciplinary project context. They also reported designing without G-SAM as a random activity and presented limited

scope for them to analyze and explore given the short time and resources available. It also proved useful in increasing the depth of analysis and generating ideas while reducing factual errors and misunderstandings. The time required for using G-SAM is substantial. However, compared with the “no design support” scenario, the time required to search for transdisciplinary know-how is considerably reduced.

The second group was provided with a YouTube video (<https://youtu.be/r8AO3F6GfO0>) with instructions on using G-SAM. Four out of seven participants reported G-SAM as difficult to use; two said it was just right, while one said it was easy. However, all of them found it very useful for conducting assessment and design. Most of them (5 out of 7) said that they can use it for field data collection, while all of them opined that it can be used to conduct participatory design sessions. Except for one participant, all found G-SAM helpful on relevance to use and implement versus not having any toolkit. One participant said, *“Designing without a toolkit was making many of these aspects invisible during the design session.”* Five of them reported that they could ideate better with G-SAM. All participants found G-SAM informative, making the task of designing SAM more organized and broadening analysis and exploration width. However, they also wanted the tool's usability to be improved. In its current form, G-SAM is just a set of guidelines and was delivered to the participants using a pdf/ excel sheet. A comprehensive tool design for appropriate delivery of the guidelines is still to be formulated and outside this thesis's scope.

7.3.3.4. Data availability, Data correctness, Transparency, and Knowledge hybridization

Transdisciplinary data was readily available to all participants through G-SAM for rapid analysis and design. The data was rated helpful in conducting rapid assessment and design. G-SAM helped in reducing the percentage of misunderstanding or factual error-based analysis or design for students. The easy availability of transdisciplinary knowledge helped students in making informed trade-off decisions. Nine students said that G-SAM helped them in identifying these trade-offs. Also, certain aspects of sustainability might not be under the direct control of the PSS stakeholders. Nine students said that the toolkit did not help them identify these, five said it did, while one gave no response. Thus, to some extent, G-SAM aided in building better transparency in decision-making through knowledge hybridization for the student group. Half of the participants felt that G-SAM helped them identify trade-offs and factors not under the PSS stakeholders' direct control for the second group. Successful knowledge hybridization was apparent for this group as well. A hands-on application context might have presented a better scenario for evaluating these criteria than the current retrospective evaluation method used with the professionals.

7.3.3.5. Communication aid, Organization of discussion sessions

Most participants felt that G-SAM could be used as a communication aid between stakeholders. It can also be used for collecting field data from experts and also for organizing participatory design sessions.

7.3.3.6. Degree of systemic knowledge captured

Thirteen students reported that they saw some of the G-SAM DC were related to each other, and their values affected each other. They made the following comments regarding the relationships:

- ♦ *“Could see a relation between service, system & product levels but not between the dimensions.”*
- ♦ *“The link between socio-economic factors.”*
- ♦ *“Trade-off thinking between factors.”*

- ◆ *“The link between a product system and relevant service systems.”*
- ◆ *“Helped in deciding on the dimension to start the design with.”*
- ◆ *“Linked diagnostic features helped to relate between system, service, and product design levels.”*

Ten students said that G-SAM helped them imagine an AM as a component in an extensive system, which also needs to be appropriately designed. Two students said it did not help them see the same; two gave no response to the question, while one person's answer was ambiguous (language issues). The students who responded affirmatively said that the toolkit shows the different perspectives, impact on socio-economic aspects, systemic viewpoint towards design, PSS thinking and, thus, helps them in seeing the machine in the context of the more extensive system. The other students (except for one ambiguous response) did not answer the how question.

Two participants from the second group reported that they saw some of the G-SAM DC were related to each other, and their values affected each other. Two others said no for the same, while three others did not respond. Four of the second group of participants reported that G-SAM helped them see AM as a component in an extensive system, which also needs to be appropriately designed. One said no for the same as he thought his design context had a very complex product and system. Two others did not provide any response.

7.3.3.7. Prioritize-ability of the targets

Eleven students and four participants from the second group (two did not respond) said that the toolkit helped them prioritize sustainability targets for their projects.

7.3.3.8. Effectiveness of target knowledge generated

All participants found G-SAM was useful in opening their minds to the various aspects of sustainability, broadened their perspective of the scope of DfS, helped them see the systemic nature of the problem, and thus the need for systems thinking. It helped in DfS in an informed fashion rather than the earlier common-sense approach. The common-sense approach led to factual errors, misunderstandings, and a lesser degree of analysis and idea generation. Thus, G-SAM helped in learning function. Since it could be used for organizing discussions and participatory sessions, it also fulfilled the communication and management function. However, some participants reported that they had no clue how to bind the diverse ideas generated into concepts. This can be attributed to the fact that the D-SAM methodology was not presented to them. D-SAM stages 3 to 5 help in doing the same.

7.4. Validation

G-SAM was applied to eight different SAM problem statements and two developing country contexts. Apart from one participant with the problem statement *“design a tool and technique for harvesting water chestnut crops to reduce farmers’ drudgery,”* all others could use G-SAM effectively. The seven projects which could benefit from G-SAM belonged to a diverse class of machinery. The ginger and turmeric washing machine and turmeric steamer are post-harvest machineries. The autopilot tractor and single-bed micro-tiller are soil preparation machinery. The uncrewed aerial vehicle to apply fertilizer is plant care machinery, while the other two machineries are harvesters. Thus, the applicability of G-SAM for the problem class SAM for small farms of developing countries is broad.

7.5. Conclusion

In the absence of any guideline, the given research found that students took an argumentative path to approach DfS. This scenario's act was mostly based on common sense and surface-level knowledge or misunderstandings regarding the concept of sustainability. Students inherently adopted a systemic approach to DfS problem-solving. Also, prioritizing one aspect over another and making trade-offs was natural amongst them. As reported by [Björklund \(2013\)](#), we did observe novice (student) designers' struggles in "*defining and structuring wicked design problems*" in the absence of guiding design support. G-SAM's introduction helped the students achieve a better extent, depth, and level of detail in both analysis and design. They could establish and accommodate more interconnections and became more geared toward action.

The design of sustainable farm machinery-based PSS is a complex and wicked problem. It involves integrating several vertical and horizontal systems, and so does interdisciplinary knowledge integration and a multitude of stakeholder interest integration. In short, students need to learn to deal with interrelated issues that require cross-disciplinary and trans-disciplinary knowledge and expertise. The introduction of G-SAM aided in conducting DfS based on facts and principles drawn from transdisciplinary literature. This improved the depth of analysis and the width of idea exploration. It also helped in reducing the percentage of factual errors and misunderstandings. It reduced the time required to hunt transdisciplinary knowledge. It was useful in opening the students' minds to the various aspects of sustainability, broadened their perspective of the scope of DfS, helped them see the systemic nature of the problem, and thus the need for systems thinking. Thus, the learning experience of the students improved, and they could gain the twelve much needed key competencies for DfS as detailed out by [Lozano et al. \(2017\)](#): (1) systems thinking; (2) interdisciplinary work; (3) anticipatory thinking; (4) justice, responsibility, and ethics; (5) critical thinking and analysis; (6) interpersonal relations and collaboration; (7) empathy and change of perspective; (8) communication and use of media; (9) strategic action; (10) personal involvement; (11) assessment and evaluation; (12) tolerance for ambiguity and uncertainty. Thus, we conclude that the use of G-SAM for teaching sustainability-orienting analysis and design of complex and wicked sustainable PSS problems (like SAM and its allied agro-ecosystem)

- ◆ Strengthens the analysis and design process
- ◆ Reduces the number of factual errors and misunderstandings
- ◆ Enhances the learning experience

For the second group of participants, which consisted of neo-professionals and professionals, G-SAM provided a structured and broad base for sustainability assessment and design ideation. This was irrespective of the disciplinary background of the participant. It *unhides* a large number of (un)sustainability issues in their projects. They stressed the need for a more user-friendly toolkit presenting the set of guidelines.

8. Conclusion

This chapter highlights the thesis's key research findings, significant theoretical contributions, and research limitations. It concludes with a discussion on the scope for future research in the given domain.

Communication

Key research findings
Theoretical contributions
Limitations
Future research

8.1. Key research findings

The key research findings are as follows:

1. SAM is comprised of the AM and its ecosystem that may include services for activities like manufacturing, distribution, maintenance, spare parts handling, training, machine operation, financial support, and others. Thus, approaching SAM as S.PSS design, focusing on the entire business ecosystem's design rather than standalone products or single aspects, is required to achieve sustainability. The S.PSS-oriented design approach should connect the "*technical, economical and engineering aspects*" of machinery design with the allied service ecosystem. The allied service ecosystem should contain "*linkages and inter-dependencies with other sectors,*" which will together offer a holistic view of conducting agriculture. The design process entails integrating a multitude of stakeholders, both large- and small-scale, highly educated and semi-literate or illiterate. These findings are in-line with the suggestions of [FAO \(2016b\)](#).
2. SAM and its associated service ecosystem design need due consideration to the following three aspects:
 - a. SAM should be designed for sustainability over the entire life cycle. That includes design, development, manufacturing, sale, use, repair, maintenance, and disposal stages.
 - b. The S.PSS development should consider strategies to make the system accessible to smallholders.
 - c. Design for SAM should target sustainability on all three dimensions concurrently. However, each dimension can be given contextually appropriate sustainability priority.
3. As SAM's product component, the AM, is a significant contributor to environmental (un)sustainability, LCA should be an integral part of the assessment process and LCD for the design process.
4. The thesis findings agree with López-Ridaura's (2002) suggestion that the design support should aid in balancing short-term oriented economic and agronomic indicators with the long-term oriented economic, social, environmental, and agronomic indicators. It should be adaptable for varying data and resource levels, depending on technical and financial resource availability. It should aid design and assessment through a participatory process by an interdisciplinary team, consisting of all stakeholders, experts, and external evaluators.
5. Consequently, the process of sustainability-oriented design of SAM should be viewed from three perspectives:
 - a. Perspective 1: S.PSS design - Here, the focus is on designing integrated combinations of products and services that meet a unit of satisfaction for the customers. It maps the entire consumption and production value chain and achieves sustainability across all three dimensions: social, economic, and environmental.
 - b. Perspective 2: Design for a sustainable agricultural outcome - Here, the focus is on having a sustainable outcome on the agricultural ecosystem, value chain, and stakeholders.
 - c. Perspective 3: Environmentally sustainable product design - Here, the focus is on developing products with better environmental performance than existing solutions.
6. The design support for the sustainability-oriented design of SAM should consist of:

- a. An overarching design methodology to aid in strategic analysis, opportunity exploration, system concept design, product and system detailing and engineering. The methodology should suggest appropriate tools and processes.
 - b. A set of guidelines to aid in sustainability assessment and design ideation, considering the above mentioned three perspectives and three sustainability dimensions.
 - c. A toolkit to operationalize the above guidelines.
7. The set of guidelines that aids sustainability assessment and design should possess the following characteristics:
- a. Compatible with little data, rapid sustainability assessment, and aid in generating a large pool of design ideas.
 - b. User-friendly defined in terms of (1) understandability of the tool for the designer, (2) ease of using it, (3) usability, (4) time requirement, and (5) flexibility and adaptability to different design scenarios, data type and availability, resource type and availability, to expert and participatory approach.
 - c. Help the designer recognize the interdependencies between indicators.
 - d. Help the designer recognize and make informed trade-offs.
 - e. Help the designer identify the aspects that are not under the control of the PSS stakeholders but has more global connectivity.
 - f. Aid in bringing greater transparency in design decisions.
 - g. Aid in communication between stakeholders.
 - h. Support the designer in gathering field data, data from experts, and in conducting participatory design sessions.
 - i. Aid the designer through knowledge hybridization by bringing in transdisciplinary perspective and knowledge.
 - j. Capture systemic knowledge.
 - k. Aid in context-appropriate prioritization of dimensions and criteria.
 - l. Aid in defining goals to better deal with problems.
 - m. Aid in various functions like monitoring, communication, learning, and management.
 - n. The design guidelines should provide open-ended ideation cues to guide, educate, and inform a designer during the design process, as [Lofthouse \(2006\)](#) suggested.

8.2. Thesis contributions

The thesis contributions are as follows:

8.2.1. G-SAM – Guidelines for sustainable agricultural mechanization

The most significant theoretical contribution of the thesis is developing a set of guidelines for the design of sustainable agricultural mechanization. Researchers ([Baudron et al., 2015](#); [Bezruk et al., 2014](#); [Brinks and Kool, 2006](#); [Corti et al., 2015](#); [Gathorne-Hardy, 2016](#); [Hendrickson et al., 2008](#); [Jongebreur and Speelman, 1997](#); [Romanelli and Milan, 2012](#); [Sims and Kienzle, 2015, 2016, 2017](#); [Sims et al., 2016](#); [Sims and Kienzle, 2006](#); [Sims and Kienzle, 2009](#); [Sims et al., 2012](#); [Veisi, 2012](#); [Vieri and Sarri, 2010](#); [Ziout and Azab, 2015](#)), as well as [FAO \(2016b\)](#), provide a broad outline for the design for SAM. However, there are no detailed sustainability-oriented design or assessment supports available to aid a designer in the complex challenge.

G-SAM provides a set of sustainability-oriented design guidelines which can be used to:

1. Analyze the sustainability of an AM based PSS for the small farms of developing countries on the three sustainability dimensions and throughout its lifecycle.
2. Determine sustainability priorities for design intervention; and
3. Generate sustainability-oriented design ideas.

It aids in

- ♦ connecting the “*technical, economical and engineering aspects*” of machinery design with the allied service ecosystem
- ♦ establishing the “*linkages and inter-dependencies with other sectors*”
- ♦ to offer a holistic view of conducting agriculture.

G-SAM is designed primarily for the use of designers and AM design engineers. These two groups are mainly involved in the design and development of AM. G-SAM can be used by others as well if the team involves designers or AM design engineers. Its assessment indicators and design guidelines help develop “*mechanization that is economically feasible, environmentally sensitive and socially acceptable.*” It targets PSS level assessment and design and can cater to the product, service, and system levels. It caters to three dimensions of sustainability: environmental, economic, and social. It uses rapid sustainability assessment indicators to conduct the evaluation and can be used even when less information is available. That is mostly the case in small farms of developing countries and at the design process’s fuzzy front-end. The design guidelines provide open-ended ideation cues to guide, educate, and inform a designer during the design process. It also aids designers in conducting analysis and ideation simultaneously.

The assessment indicators and design guidelines are drawn from

- ♦ other indicator-based assessment tools from agricultural practices, S.PSS, and LCD, along with
- ♦ literature research reporting the short and long-term impact of AM on the soil, air, water, energy, biodiversity, waste, and climate.

The indicators are adapted to the context of SAM, considering the short-term and long-term impact.

The structure of G-SAM is demarcated into three-levels: Dimension, Criterion, and Impact Category. All criteria have three common impact categories: System-Level, Service-Level, and Agricultural Machine Characteristics (Product-Level) to aid in viewing and identifying the connections between the levels to achieve sustainability. The environmental dimension has additional impact categories, drawn from the physical systems of an agricultural ecosystem.

8.2.2. D-SAM – A methodology for the sustainability-oriented design of agricultural mechanization

Another theoretical contribution of the thesis is developing a methodology for the sustainability-oriented agricultural mechanization design, called D-SAM. The methodology consists of five stages: 1. Strategic analysis; 2. Exploring opportunities; 3. Designing system concepts; 4. Product designing and engineering; 5. System designing and engineering. Each stage consists of multiple processes and tools. It is built with the MSDS methodology ([Vezzoli et al., 2014](#)), an S.PSS design methodology, as the base. D-SAM strengthens MSDS to meet the requirements of SAM design context in the following ways:

1. MSDS lays focus on service and system design. To bring product design focus:
 - a. D-SAM adds a process, product analysis, to *Stage 1: Strategic Analysis*. Herein, the existing solutions are studied to identify the ergonomics, engineering, and manufacturing requirements and shortcomings. The input so generated is fed into G-SAM for environmental analysis of the existing solutions and sustainability priority setting for design intervention. It also serves as pointers for performing technology macro-trends study and understand the system carrying structure.
 - b. D-SAM adds *Stage 4: Product designing and engineering*, as the fourth stage, between *Stage 3: Designing system concepts* and *Stage 5: Designing and engineering system* (stage 4 in MSDS).

This stage aims to design and engineer the AM. It is introduced before *Stage 5: System designing and engineering* so that before finalizing the system design, the designer is fully aware of the product component in the PSS. Stage 3 and 4 in practice can go hand in hand or in any other order deemed fit by the design team.

- c. G-SAM guidelines replace the SDO toolkit. The guidelines help in assessment and design like the SDO toolkit. However, G-SAM covers three perspectives, S.PSS design, design for sustainable agricultural outcome, and environment-friendly product design. Therefore, the assessment and design focus expand from the earlier service and system focus to product, service, system, and agronomic focus.
2. MSDS does not cater to the specific needs of sustainability for agricultural practices. G-SAM fills up that gap.
3. MSDS lays focus on participatory design. D-SAM stresses the need to develop participatory design methods that can bring forth a cohesive participatory design process involving highly educated and semi-literate and illiterate stakeholders simultaneously. However, such a method is out of the scope of the thesis.

Thus, D-SAM helps in

- ♦ strategic analysis, including a sustainability assessment of the existing scenario and sustainability priority setting for the design intervention,
- ♦ ideation process,
- ♦ design and engineering of the product, service, and system, and
- ♦ the sustainability improvement or worsening assessment of the redesigned SAM offer.

8.2.3. Design of a power tiller-based bed planter

A power tiller-based BP was designed, prototyped, and tested.

8.2.4. Pedagogy development for designing SAM

The evaluation of G-SAM with student designers led to the formulation of a pedagogy strategy for teaching design students designing for SAM. The pedagogy was drawn considering the twelve key competences suggested by [Lozano et al. \(2017\)](#): (1) systems thinking; (2) interdisciplinary work; (3) anticipatory thinking; (4) justice, responsibility, and ethics; (5) critical thinking and analysis; (6) interpersonal relations and collaboration; (7) empathy and change of perspective; (8) communication and use of media; (9) strategic action; (10) personal involvement; (11) assessment and evaluation; (12) tolerance for ambiguity and uncertainty. The pedagogy helped students in better “*defining and structuring wicked design problems*” as per the suggestions of [Björklund \(2013\)](#).

8.2.5. Analysis and categorization of existing design support for S.PSS

Several studies on PSS design support classification were found. However, not all of them dealt with the concept of sustainability. For example, [Boehm and Thomas \(2013\)](#) reviewed 265 papers, 115 of which dealt with the conceptualization of design supports for PSS, while only 23 dealt with the concept of sustainability. According to [Ceschin, F. \(2013\)](#), PSS business models can be distinguished into two categories: conceptualized to be eco-efficient and sustainable while the others are not. Researchers have also shown case studies where PSS can harm the environment while maintaining its profitability ([Kuo, 2010](#); [Tukker, 2004](#)). Hence a PSS needs to be consciously designed, keeping in mind sustainability concerns and strategize to avoid rebound effects ([Tukker, 2004](#); [Tukker, Arnold and Tischner, Ursula, 2006](#); [Vezzoli et al., 2014](#)).

Thus, literature research for identifying design supports for S.PSS was conducted, the supports were categorized, and the target sectors were highlighted. The categories are:

1. S.PSS design support – This includes all those papers that present design supports for either only S.PSS design, ideation, innovative thinking for S.PSS design, or involve supports for a combination of stages: analysis, design (must-have), and evaluation. Twenty-five of these supports targeted S.PSS design, six targeted business model design and four for service design for S.PSS.
2. S.PSS evaluation support – This includes support for evaluating an S.PSS on parameters like sustainability potential, performance, monitoring, efficiency, value, and customer satisfaction. Nineteen such supports are identified.
3. S.PSS modeling and simulation support – This includes supports to aid in simulation and modeling various S.PSS aspects like life cycle, design phases, networks, innovations, services, and piloting. Ten such supports are identified.
4. S.PSS operation supports – This includes supports for managing or mapping operational aspects like sustainable consumption typology, a framework for analyzing business-to-customer cases, life cycle management and acquisition, the role of social process for sustainable consumption, strategic design, and transition management. Eighteen such papers were identified.

8.2.6. Analysis of the nature of LCA-based research in AM

LCA research for sustainable AM is a common phenomenon. A categorization of the research is done to understand the impact domains and the gaps for future exploration. The categorization shows an enormous scope for future research in the following areas:

- ♦ LCA applied to PSS,
- ♦ Combining LCA with socio-economic efficiency,
- ♦ Usage modeling for LCA or Artificial Intelligence-based LCA for the consumption side,
- ♦ LCA dataset analysis or generation.

The majority of the LCA research in AM focused on comparing various competing scenarios based on product design, processes and stages, geographies, time, and operation size. A third of these studies originate from Italy. Only 4% of the studies have been conducted in the context of small farms in developing countries. Thus, the analysis shows that LCA-based research in AM design is also in its nascent stage.

8.2.7. Critical success criteria for the assessment of sustainability-oriented design supports for SAM

A set of critical success criteria for the implementation of sustainability-oriented design support for SAM is drawn. The set combines the assessment and design knowledge from DfS in the context of S.PSS and assessment knowledge from agricultural practices, contextualized for SAM.

8.2.8. A framework to develop sustainability assessment and design supports for SAM

Literature research reveals several sustainability assessment supports from agricultural practices. However, no design supports are available. Besides, no assessment or design support for SAM is present. Thus, a framework to develop sustainability assessment and design supports for SAM has been proposed. The framework combines assessment support development aspects from agricultural practices along with design and assessment support development aspects from S.PSS, contextualized for SAM.

8.3. Limitations

The limitations of the research are as follows:

1. SAM design support development has been done with a real case study wherein the entire design phase was carried forth. This involved conducting field research, research with stakeholders, design ideation, conceptualization, prototype building, and testing. However, the evaluation of SAM design support could not be conducted with the same degree of rigor. This was due to the long-time frame required to design and develop a SAM case study and the large volume of resources required. In order to evaluate G-SAM's efficacy statistically, student designers were used so that they could be engaged for an entire semester and in larger numbers. This kind of engagement was not possible to achieve from professional designers. The professional designers assessed G-SAM by retrospectively comparing their experience of designing AM without any support versus using G-SAM. A more in-depth evaluation of G-SAM could have been done if professional designers could have been engaged in live case studies wherein the entire design phase is carried forth.
2. G-SAM and D-SAM were developed as a result of testing MSDS and ICS toolkit on one live SAM design context. More gaps and opportunities could have been identified if a greater number of SAM design contexts were available from literature or as live projects. Literature did not report any such context in depths required for testing MSDS and ICS toolkit while the resources required for another live project was not feasible for the thesis timelines.
3. The evaluation of G-SAM was conducted using a before and after intervention study, i.e., an interrupted time series design, and was analyzed using a t-test. This is a quasi-experimental design method. A measure of outcome was taken before the intervention, and the same was measured after the intervention. All changes were attributed to the occurrence of the intervention. Interrupted time-series designs are being increasingly used to evaluate interventions in areas like health care behavior change, mass media, public policy, and community interventions ([Biglan et al., 2000](#); [Muller, 2004](#); [Ramsay et al., 2003](#)). These designs are a valuable and pragmatic evaluation tool when a randomized controlled trial is not feasible ([Ramsay et al., 2003](#)). One can also use statistical investigation to identify potential biases in estimating the impact of the intervention. One of the potential biases that can be introduced due to the experimental design here is autocorrelation - the extent to which data collected close together in time is correlated with each other ([Cook et al., 1979](#)). To investigate this bias, appropriate statistical tools need to be used. Currently, a t-test has been used, as is the case with many similar contexts. ([Ramsay et al., 2003](#)) The t-test would give incorrect effect sizes if preintervention trends are present and decrease the standard error if positive autocorrelation is present. A positive autocorrelation suggests that outcomes measured close together in time are similar to each other. For example, a high outcome is followed by another high outcome. Since that is not the case, the given interrupted time series design and the statistical analysis method provide a good analytical basis. However, researchers argue using other statistical analysis methods to rule out some of the potential biases ([Ramsay et al., 2003](#)). Detailed investigation on these was out of the scope of the thesis.
4. G-SAM at the time of testing was a set of guidelines delivered using PDF or Excel sheet. As a large amount of data was delivered to the test participants, the guidelines' cognitive load was high. Participants also reported the same in their feedback on G-SAM. As a result of the cognitive load, the experience of using G-SAM, and the efficacy of the guidelines might have suffered a setback too. In the future, when a user-friendly tool is developed for delivering G-SAM, it is expected that the participants' performance and acceptability of it will improve further. The design and development of this tool were out of the scope of the thesis.
5. Currently, G-SAM focuses mostly on AM for soil-based agriculture. It can be further enhanced to cover other forms of agriculture like aquaculture, pisciculture.

6. Participatory design with stakeholders having wide variations in education and experience typology is key to the success of design for SAM. However, specific guidelines for the same were out of the scope of the thesis.

8.4. Future research

In 2016, FAO set up its broad guidelines on sustainable agriculture and mechanization. D-SAM and G-SAM are the first of their kind of design and assessment support for the design and development of sustainable agricultural mechanization. Thus, it opens a broad scope for future research and development. A critical future research area is around the design and development of a user-friendly toolkit to deliver G-SAM. This will aid in the adoption and dissemination of the framework. Further evaluation and refinement of both D-SAM and G-SAM through dissemination amongst industry participants across various developing countries need to be undertaken. G-SAM can be further strengthened with design and assessment guidelines drawn from research on agricultural practice domains like aquaculture, pisciculture, hydroponics, animal husbandry.

Research methodology development for participatory design with stakeholders having wide variations in education and experience typology is another potential research area. During the prototype building process, a participatory design process was conducted with the manufacturer's staff. That gave a good insight into practical manufacturing issues of small-scale AM manufacturers in developing countries and adapting the AM design accordingly. This opens up another potential domain for future research on developing participatory design techniques for improving manufacturing and assembly of engineering products using the tacit knowledge of manufacturing staff.

9. Publications

1. Banerjee, S., Punekar, R.M., 2020. A sustainability-oriented design approach for agricultural machinery and its associated service ecosystem development. *Journal of Cleaner Production* 264.
2. Banerjee, S., 2019. PURA framework - A model for Distributed Economy for India, in: Ambrosio, M., Vezzoli, C. (Eds.), *Designing Sustainability for All - 3rd LeNS world distributed conference*. Edizioni POLI.design, Milano, Italy, pp. 265-269.
3. Banerjee, S., Upadhyay, P., Punekar, R.M., 2019. Contextualising sustainable Product-Service design methods for Distributed Economies of India, in: Ambrosio, M., Vezzoli, C. (Eds.), *Designing Sustainability for All - 3rd LeNS world distributed conference*. Edizioni POLI.design, Milano, Italy, pp. 270-275.
4. Banerjee, S., 2015. Case Study - Giving voice to the farmers, machine operators, local service providers and small-scale manufacturers in designing scale-appropriate agro-machinery for rural Bangladesh, ICCIG3 2015. Ahmedabad.

In Progress

5. Banerjee, S., Punekar, R.M., ____. G-SAM - A sustainability-orienting design guideline for agricultural machinery based sustainable product-service system. Submitted.
6. Banerjee, S., Punekar, R.M., ____. Efficacy of Teaching Design for Sustainability using Design Supports. Submitted.
7. Banerjee, S., ____. Review of sustainable product-service system design supports. Submitted.

Appendix 1

Distribution of smallholdings across the globe

Table A1. 1. Distribution of smallholdings across the globe (adapted from (Lowder et al., 2016)).

Country	Census Year	Total holdings	Total operated area (ha)	Agricultural holdings <1 ha		Agricultural holdings 1-2 ha		Income Group	Region	Economic Classification
				% of holdings	% of Operated Area	% of holdings	% of Operated Area			
Albania	1998	466809	1889498	60	7	30	11	UMI	R2	ET
Algeria	2001	1023799	8458680	22	1	13	2	LMI	R4	DGE
American Samoa	2003	7094	7949	57	19	26	28	UMI	R1	DGE
Australia	1990	129540	HI	R1	DDE
Austria	1999-2000	199470	6804610	15	2	HI	R2	DDE
Bahamas, The	1994	1760	20336	36	1	25	3	HI	R3	DGE
Barbados	1989	17178	21560	95	10	3	3	HI	R3	DGE
Belgium	1999-2000	61710	1426780	17	1	HI	R2	DDE
Brazil	1996	4838183	353611246	11	0.1	10	0.2	UMI	R3	DGE
Bulgaria	2003	665500	2904500	77	7	UMI	R2	DDE
Burkina Faso	1993	886638	3472480	13	2	19	7	LI	R6	DGE
Canada	1991	280043	67753700	2	...	HI	R5	DDE
Chile	1997	316492	26502363	15	0.1	10	0.2	HI	R3	DGE
China	1997	19344600	130039200	93	...	5	...	UMI	R1	DGE
Colombia	2001	2021895	50705453	18	0.4	14	1	UMI	R3	DGE
Côte d'Ivoire	2001	1117667	4351663	42	5	14	5	LMI	R6	DGE
Croatia	2003	449896	1391622	51	6	16	7	HI	R2	DDE
Cyprus	2003	45199	156380	55	6	17	7	HI	R2	DDE
Czech Republic	2000	56487	3643168	29	0.1	15	0.3	HI	R2	DDE
Democratic Republic of the Congo	1990	4479600	2387700	87	63	10	23	LI	R6	DGE
Denmark	1999-2000	57830	2878730	2	0.1	HI	R2	DDE
Djibouti	1995	1135	...	83	...	17	...	LMI	R4	DGE
Dominica	1995	9026	21146	53	8	21	15	UMI	R3	DGE
Ecuador	1999-2000	842882	12355831	29	1	14	1	UMI	R3	DGE
Egypt, Arab Rep.	1999-2000	4541884	3750699	87	37	8	18	LMI	R4	DGE

Country	Census Year	Total holdings	Total operated area (ha)	Agricultural holdings <1 ha		Agricultural holdings 1-2 ha		Income Group	Region	Economic Classification
				% of holdings	% of Operated Area	% of holdings	% of Operated Area			
Estonia	2001	68869	875799	20	1	20	2	HI	R2	DDE
Ethiopia	2001-2002	10758597	11047249	63	27	24	33	LI	R6	DGE
Fiji	1991	95400	591407	43	2	12	3	UMI	R1	DGE
Finland	1999-2000	81200	5865530	3	1	HI	R2	DDE
France	1999-2000	663810	29897670	17	1	HI	R2	DDE
Georgia	2003-2004	729542	886766	70	24	23	23	UMI	R2	ET
Germany	1999-2000	471960	19097990	8	0.3	HI	R2	DDE
Greece	1999-2000	817060	3875180	49	11	HI	R2	DDE
Grenada	1995	18277	14164	85	18	8	14	UMI	R3	DGE
Guam	2002	153	667	30	3	16	4	HI	R1	DGE
Guatemala	2003	830684	3750855	78	12	10	7	UMI	R3	DGE
Guinea	1995	442168	895620	34	10	31	22	LI	R6	DGE
Guinea-Bissau	1988	84221	96375	70	...	18	...	LI	R6	DGE
Hungary	2000	966916	6448000	27	...	13	...	HI	R2	DDE
India	2001	119894000	159394000	63	19	19	20	LMI	R7	DGE
Indonesia	1993	19713806	17145036	71	30	17	25	UMI	R1	DGE
Iran, Islamic Rep.	2003	4332423	17665198	47	2	12	4	UMI	R4	DGE
Ireland	2000	141530	4714970	2	0.1	HI	R2	DDE
Italy	2000	2590674	19607094	38	2	19	4	HI	R2	DDE
Jamaica	1996	187791	407434	69	11	15	9	UMI	R3	DGE
Japan	1995	3444000	4120000	68	25	20	23	HI	R1	DDE
Jordan	1997	88452	278589	54	4	32	22	UMI	R4	DGE
Republic of Korea	1990	1768501	1857491	59	31	31	41	HI	R1	DGE
Kyrgyz Republic	2002	1130855	1306787	85	8	7	8	LMI	R2	DGE
Lao People's Democratic Republic	1998-1999	668000	1047700	38	13	35	30	LMI	R1	DGE
Latvia	2001	180263	3586200	0.0	...	6	0.4	HI	R2	DDE
Lebanon	1998	194829	247940	73	20	14	15	UMI	R4	DGE
Lesotho	1989-1990	229300	331000	47	...	29	...	LMI	R6	DGE
Libya	1987	175528	2495906	14	...	10	...	UMI	R4	DGE

Country	Census Year	Total holdings	Total operated area (ha)	Agricultural holdings <1 ha		Agricultural holdings 1-2 ha		Income Group	Region	Economic Classification
				% of holdings	% of Operated Area	% of holdings	% of Operated Area			
Lithuania	2003	278563	2939100	0.2	0.003	8	1	HI	R2	DDE
Luxembourg	1999-2000	2810	137600	12	0.3	HI	R2	DDE
Malawi	1993	1561416	1167240	78	...	17	...	LI	R6	DGE
Mali	2004-2005	805194	...	32	...	14	...	LI	R6	DGE
Malta	2001	11959	9656	76	33	15	25	HI	R4	DDE
Morocco	1996	1496349	8732223	25	2	18	5	LMI	R4	DGE
Mozambique	1999-2000	3037782	3925324	54	...	30	...	LI	R6	DGE
Myanmar	2003	3464769	8721115	34	5	23	14	LMI	R1	DGE
Namibia	1996-1997	102357	295632	14	3	25	13	UMI	R6	DGE
Nepal	2002	3364139	2654037	75	39	17	30	LMI	R7	DGE
Netherlands	1999-2000	101550	2239290	16	1	HI	R2	DDE
New Zealand	2002	70000	15640348	HI	R1	DDE
Nicaragua	2001	199549	6254514	12	0.3	9	0.5	LMI	R3	DGE
Northern Mariana Islands	2002	214	952	26	3	28	7	HI	R1	DGE
Norway	1999	70740	1038246	2	0.03	4	0.3	HI	R2	DDE
Pakistan	2000	6620054	20406782	36	6	22	10	LMI	R7	DGE
Panama	2001	236613	2769528.92	53	1	10	1	HI	R3	DGE
Paraguay	1991	307221	23817737	10	0.04	10	0.1	UMI	R3	DGE
Peru	1994	1756141	35381809	UMI	R3	DGE
Philippines	2002	4822739	9559958	40	9	28	17	LMI	R1	DGE
Poland	2002	2933000	19324800	33	3	18	5	HI	R2	DDE
Portugal	1999	415969	5188955	27	3	28	6	HI	R2	DDE
Puerto Rico	2002	17659	271440	HI	R3	DGE
Qatar	2000-2001	3553	42328	69	1	5	1	HI	R4	DGE
Romania	2002	4484893	15707957	50	5	20	8	HI	R2	DDE
Saint Lucia	1996	13366	20770	63	31	18	16	UMI	R3	DGE
Saint Vincent and the Grenadines	2000	7380	7199	73	19	15	21	UMI	R3	DGE
Samoa	1999	14734	53382	19	2	32	11	UMI	R1	DGE
Senegal	1998-1999	437037	1877684	21	2	17	6	LMI	R6	DGE
Serbia	2002	778891	1919423	28	5	19	9	UMI	R2	ET

Country	Census Year	Total holdings	Total operated area (ha)	Agricultural holdings <1 ha		Agricultural holdings 1-2 ha		Income Group	Region	Economic Classification
				% of holdings	% of Operated Area	% of holdings	% of Operated Area			
Slovak Republic	2001	71038	3462487	70	...	12	...	HI	R2	DDE
Slovenia	1991	156549	912013	28	...	13	...	HI	R2	DDE
Spain	1999	1764456	42180951	26	...	15	...	HI	R2	DDE
Saint Kitts and Nevis	1987	3269	8870	96	...	HI	R3	DGE
Sweden	1999-2000	81410	7641890	3	2	HI	R2	DDE
Switzerland	1990	108296	1262167	20	1	7	1	HI	R2	DDE
Thailand	1993	5647490	19002071	20	3	23	9	UMI	R1	DGE
Togo	1996	842124	...	10	...	20	...	LI	R6	DGE
Trinidad and Tobago	2004	19111	84990	35	3	18	5	HI	R3	DGE
Turkey	2001	3076650	18434822	17	1	18	4	UMI	R2	DGE
Uganda	1991	1704721	3683288	49	11	24	16	LI	R6	DGE
United Kingdom	1999-2000	233250	16527630	14	0.3	HI	R2	DDE
United States of America	2002	2128982	379712151	HI	R5	DDE
Uruguay	2000	57131	16419683	HI	R3	DGE
Venezuela (Bolivarian Republic of)	1996-1997	500979	30071192	9	0.1	14	0.3	UMI	R3	DGE
Viet Nam	2001	10689753	7633882	85	...	10	...	LMI	R1	DGE
Virgin Islands (U.S.)	2002	191	3710	50	2	HI	R3	DGE
Yemen, Rep.	2002	1180105	1609486	73	16	11	10	LI	R4	DGE
Zambia	1990	520520	...	0	0	0	0	LMI	R6	DGE

Index: HI - High-income, UMI - Upper-middle-income, LMI - Lower-middle-income, LI - Low-income, R1 - East Asia and Pacific, R2 - Europe and Central Asia, R3 - Latin America and The Caribbean, R4 - Middle East and North Africa, R5 - North America, R6 - Sub-Saharan Africa, R7 - South Asia, ET - Economies in transition, DGE - Developing economies, DDE - Developed Economies

Source: (Lowder et al., 2016) - Census year, total holdings, total area, agricultural holdings <1 ha and 1-2 ha, (The World Bank Group, 2020b) - Income group, region, (United Nations, 2020) - Economic classification.

Appendix 2

Research in the context of LCA applied to AM

Literature research was conducted using the keywords LCA AND agricul* AND machin* (limited to exact keywords “Agricultural Machinery” or “Machinery” and “Life Cycle Assessment (LCA)” or “Life Cycle Assessment” or “Life Cycle Analysis” and English language) on Scopus. The search resulted in 92 results (excluding the author’s paper and three other non-relevant papers). The following tables categorize the papers based on aim of the study, geography under investigation and farm size.

Table A2. 1. Categorizing the literature based on aim of the study.

Aim	Number of papers	Reference
LCA for comparing different scenarios (product design/ processes/ stages/ geography/ time/ size of operation)	78	(Aguilera et al., 2019 ; Alam et al., 2016 ; Bacenetti et al., 2016a ; Bacenetti et al., 2020 ; Bacenetti et al., 2015 ; Bacenetti et al., 2018 ; Bacenetti et al., 2016b ; Bartzas et al., 2015 ; Bernardi et al., 2018 ; Biswas et al., 2010 ; Bojacá et al., 2014 ; Bortolini et al., 2014 ; Buratti et al., 2013 ; Câmara-Salim et al., 2020 ; Carranza-Gallego et al., 2018 ; Cascini et al., 2013 ; Castanheira and Freire, 2013 ; Cerutti et al., 2014 ; De Gennaro et al., 2012 ; Elhami et al., 2016 ; Elhami et al., 2017 ; Fantozzi and Buratti, 2010 ; Felten et al., 2013 ; Foteinis and Chatzisyneon, 2016 ; Fusi et al., 2014 ; Goglio et al., 2012 ; González-García et al., 2016 ; González-García et al., 2013 ; González-García et al., 2010 ; González-García et al., 2012 ; Grados and Schrevens, 2019 ; Gunady et al., 2012 ; Guzman et al., 2016 ; Hedayati et al., 2019 ; Houshyar and Grundmann, 2017 ; Igos et al., 2016 ; Ilsen et al., 2015 ; Ingrao et al., 2015 ; Kaab et al., 2019 ; Khoshnevisan et al., 2014 ; Kim and Dale, 2008 ; Krzyżaniak et al., 2018 ; Lares-Orozco et al., 2016 ; Lee, H. et al., 2012 ; Lehmann et al., 2020 ; Lijó et al., 2014 ; Liu et al., 2010 ; Longo et al., 2017 ; Lovarelli and Bacenetti, 2017b ; Lovarelli et al., 2017 ; Lovarelli et al., 2018a ; Lovarelli et al., 2018b ; Lovarelli et al., 2020 ; Ma and Kim, 2014, 2015 ; Nalley et al., 2013 ; Ntiamoah and Afrane, 2008 ; Nunes et al., 2017 ; Nunes et al., 2016 ; Ogunjirin et al., 2020 ; Palmieri et al., 2014 ; Paramesh et al., 2018 ; Perić et al., 2018 ; Pradel et al., 2013 ; Pradhan et al., 2011 ; Proto et al., 2017 ; Pryor et al., 2017 ; Rinaldi et al., 2014 ; San Miguel et al., 2015 ; Sonderegger et al., 2020 ; Tabatabaie and Murthy, 2016 ; Tabatabaie et al., 2016 ; Tassielli et al., 2019 ; Todde et al., 2018 ; Vagnoni et al., 2015 ; Van Linden and Herman, 2014 ; Xue et al., 2016 ; Xue et al., 2014)
LCA combined with socio-economic efficiency	3	(Cardoso et al., 2018 ; Florindo et al., 2020 ; Veiga et al., 2018)
LCA combined with economic analysis	6	(Bernardi et al., 2018 ; De Gennaro et al., 2012 ; Igos et al., 2016 ; Lovarelli et al., 2018b ; San Miguel et al., 2015 ; Tabatabaie et al., 2018)
LCA on the AM consumption side only	36	(Bacenetti et al., 2020 ; Bojacá et al., 2014 ; Buratti et al., 2013 ; Câmara-Salim et al., 2020 ; Castanheira and Freire, 2013 ; Castanheira and Freire, 2012 ; De Gennaro et al., 2012 ; Elhami et al., 2016 ; Elhami et al., 2017 ; Felten et al., 2013 ; González-García et al., 2016 ; González-García et al., 2013 ; Grados and Schrevens, 2019 ; Guzman et al., 2016 ; Hedayati et al., 2019 ; Igos et al., 2016 ; Kaab et al., 2019 ; Kim and Dale, 2008 ; Lehmann et al., 2020 ; Longo et al., 2017 ; Lovarelli and Bacenetti, 2017a ; Lovarelli et al., 2017 ; Lovarelli et al., 2020 ; Nunes et al., 2017 ; Nunes et al., 2016 ; Ogunjirin et al., 2020 ; Perić et al., 2018 ; Pryor et al., 2017 ; Rinaldi et al., 2014 ; San Miguel et al., 2015 ; Tabatabaie et al., 2018 ; Tabatabaie et al., 2016 ; Tassielli et al., 2019 ; Todde et al., 2018 ; Van Linden and Herman, 2014 ; Xue et al., 2016)

LCA on the AM production and consumption side	43	(Aguilera et al., 2019 ; Alam et al., 2016 ; Bacenetti et al., 2016a ; Bacenetti et al., 2015 ; Bacenetti et al., 2018 ; Bacenetti et al., 2016b ; Bartzas et al., 2015 ; Benoist et al., 2012 ; Bernardi et al., 2018 ; Biswas et al., 2010 ; Bortolini et al., 2014 ; Carranza-Gallego et al., 2018 ; Cascini et al., 2013 ; Cerutti et al., 2014 ; Fantozzi and Buratti, 2010 ; Foteinis and Chatzisyneon, 2016 ; Fusi et al., 2014 ; Goglio et al., 2012 ; González-García et al., 2010 ; González-García et al., 2012 ; Gunady et al., 2012 ; Houshyar and Grundmann, 2017 ; Ilsen et al., 2015 ; Ingrao et al., 2015 ; Iriarte et al., 2011 ; Khoshnevisan et al., 2014 ; Kim et al., 2014 ; Krzyżaniak et al., 2018 ; Lares-Orozco et al., 2016 ; Lijó et al., 2014 ; Liu et al., 2010 ; Lovarelli and Bacenetti, 2017b ; Lovarelli et al., 2018b ; Mantoam et al., 2017 ; Ntiamoah and Afrane, 2008 ; Palmieri et al., 2014 ; Paramesh et al., 2018 ; Pradhan et al., 2011 ; Proto et al., 2017 ; Stoessel et al., 2012 ; Tabatabaie and Murthy, 2016 ; Vagnoni et al., 2015 ; Xue et al., 2014)
Usage modelling for LCA/ Artificial Intelligence based LCA for the consumption side	5	(Elhami et al., 2017 ; Kaab et al., 2019 ; Ma and Kim, 2014, 2015 ; Pradel et al., 2013)
LCA applied to PSS	1	(Glatt et al., 2019)
LCA dataset analysis/ generation	8	(Benoist et al., 2012 ; Corrado et al., 2018 ; Kim et al., 2014 ; Lovarelli and Bacenetti, 2017a ; Lovarelli et al., 2017 ; Maciel et al., 2015 ; Mantoam et al., 2017 ; Tabatabaie and Murthy, 2016)
Total Papers	92	

Table A2. 2. Categorizing the literature based on geography under investigation and farm size.

Country	Number of papers	Studies for small farms*	Reference
Global	1	-	(Sonderegger et al., 2020)
European Union	1	-	(Benoist et al., 2012)
Argentina	1	-	(Castanheira and Freire, 2013)
Australia	3	-	(Biswas et al., 2010 ; Gunady et al., 2012 ; Hedayati et al., 2019)
Bangladesh	1	-	(Alam et al., 2016)
Belgium	2	-	(Igos et al., 2016 ; Van Linden and Herman, 2014)
Brazil	9	-	(Cardoso et al., 2018 ; Castanheira and Freire, 2013 ; Castanheira and Freire, 2012 ; Florindo et al., 2020 ; Maciel et al., 2015 ; Mantoam et al., 2017 ; Nunes et al., 2017 ; Nunes et al., 2016 ; Veiga et al., 2018)
Chile	1	-	(Iriarte et al., 2011)
China	2	-	(Liu et al., 2010 ; Xue et al., 2016)
Colombia	1	-	(Bojacá et al., 2014)
Denmark	1	-	(Lehmann et al., 2020)
France	2	-	(Corrado et al., 2018 ; Pradel et al., 2013)
Germany	2	-	(Felten et al., 2013 ; Glatt et al., 2019)
Ghana	1	(Ntiamoah and Afrane, 2008)	(Ntiamoah and Afrane, 2008)
Greece	1	-	(Foteinis and Chatzisyneon, 2016)
India	1	-	(Paramesh et al., 2018)
Iran	5	(Khoshnevisan et al., 2014)	(Elhami et al., 2016 ; Elhami et al., 2017 ; Houshyar and Grundmann, 2017 ; Kaab et al., 2019 ; Khoshnevisan et al., 2014)
Italy	29	(Todde et al., 2018)	(Bacenetti et al., 2016a ; Bacenetti et al., 2020 ; Bacenetti et al., 2015 ; Bacenetti et al., 2018 ; Bacenetti et al., 2016b ; Bartzas et al., 2015 ; Bernardi et al., 2018 ; Bortolini et al., 2014 ; Buratti et al., 2013 ; Cascini et al., 2013 ; De Gennaro et al., 2012 ; Fantozzi and Buratti, 2010 ; Fusi et al., 2014 ; Goglio et al., 2012 ;

			González-García et al., 2012 ; Ingrao et al., 2015 ; Lehmann et al., 2020 ; Lijó et al., 2014 ; Longo et al., 2017 ; Lovarelli and Bacenetti, 2017b ; Lovarelli et al., 2017 ; Lovarelli et al., 2018b ; Lovarelli et al., 2020 ; Palmieri et al., 2014 ; Proto et al., 2017 ; Rinaldi et al., 2014 ; Tassielli et al., 2019 ; Todde et al., 2018 ; Vagnoni et al., 2015
Mexico	1	-	(Lares-Orozco et al., 2016)
Nigeria	1	-	(Ogunjirin et al., 2020)
Peru	1	(Grados and Schrevens, 2019)	(Grados and Schrevens, 2019)
Poland	1	-	(Krzyżaniak et al., 2018)
Portugal	2	-	(Castanheira and Freire, 2012) ; González-García et al., 2013
Republic of Serbia	1	-	(Perić et al., 2018)
South Africa	1	-	(Pryor et al., 2017)
South Korea	1	-	(Lee, H. et al., 2012)
Spain	9	-	(Aguilera et al., 2019) ; Bartzas et al., 2015 ; Câmara-Salim et al., 2020 ; Carranza-Gallego et al., 2018 ; González-García et al., 2016 ; González-García et al., 2010 ; González-García et al., 2012 ; Lovarelli et al., 2020 ; San Miguel et al., 2015
Sweden	2	-	(Lovarelli and Bacenetti, 2017a) ; Lovarelli et al., 2018a
Switzerland	1	-	(Stoessel et al., 2012)
US	9	-	(Guzman et al., 2016) ; Kim and Dale, 2008 ; Kim et al., 2014 ; Nalley et al., 2013 ; Pradhan et al., 2011 ; Tabatabaie et al., 2018 ; Tabatabaie and Murthy, 2016 ; Tabatabaie et al., 2016 ; Xue et al., 2014
Total Papers#	92	4	

* Includes those where it is mentioned that the study considered small farms.

Some papers consider two countries.

Appendix 3

S.PSS design supports

Table A3. 1. S.PSS research that deals with the proposal of a design framework, methodology, guidelines, or tool.

Sr. No.	Category	Reference	Name/ Aim of the Design Support/ Project Name	Target Sector
<i>S.PSS Design Supports</i>				
1	S.PSS Design	(Luiten et al., 2001)	The Kathalys Method	Any S.PSS
2		(Maxwell and Van der Vorst, 2003) (Maxwell et al., 2006)	Sustainable Product and Service Development (SPSD) method	Original Equipment Manufacturers
3		(Morelli, 2006)	Methods for mapping the actors involved in developing and delivering PSS, to define the requirements and structure of a PSS and to represent and blueprint a PSS.	Any S.PSS
4		(Afshar and Wang, 2010)	–	Any S.PSS
5		(Tischner and Vezzoli, 2009a, b)*	Tools and cases inspired by the experience of projects like Methodology PSS (MEPSS) toolkit, SusProNet	Any S.PSS
6		(Joore et al., 2004)*	SusProNet	Food industry
7		(Fornasiero and Sorlini, 2010)	ID-ProSer	Small and medium enterprises
8		(Geum and Park, 2011)	Product-service blueprint approach	Any S.PSS
9		(Huang et al., 2012)	Goal Programming (GP) model	Any S.PSS
10		(Yixiang et al., 2012)	Value gap model of PSS development & design	Any S.PSS
11		(Kondoh and Komoto, 2013)	Eco-business planning: Idea generation method	Any S.PSS
12		(Liedtke et al., 2013)	Eco-intelligent product service-arrangements	Any S.PSS
13		(Ny et al., 2013)	Strategic tools for sustainable PSS development	Any S.PSS
14		(Park and Yoon, 2013)	A chance discovery-based approach for new PSS concepts	Any S.PSS
15		(D'Anna and Cascini, 2010)	The SUSTAINability map	Any S.PSS
16		(Brezet et al., 2001)*	DES Methodology	Any S.PSS
17		(Meier et al., 2010)	–	Industrial Product-Service Systems
18		(Peruzzini et al., 2014)	A QFD-based methodology to support PSS design in the manufacturing industry	Manufacturing companies moving from products to services
19		(Ribeiro and Borsato, 2014)	'enhanced' NPD process model	Any S.PSS
20		(Zhang et al., 2014)	City-Product Service System engineering	City design
21		(Vezzoli et al., 2014)	Methodology for System Design for Sustainability (MSDS)	Any S.PSS
22		(Joore and Brezet, 2015)	A Multilevel Design Model: the mutual relationship between PSS development and societal change processes	Socio-technical and societal problems

Sr. No.	Category	Reference	Name/ Aim of the Design Support/ Project Name	Target Sector
23		(Peruzzini et al., 2015)	Quality functional deployment (QFD) approach for defining a set of robust requirements for creating new PSSs with specific customer needs and sustainability principles of the industrial network.	Industrial network
24		(Pialot et al., 2015)	An eco-innovative method based on upgradability	Design for upgradability – to facilitate remanufacturing, PSS, or for increasing the lifetime of the product
25		(Pigozzo and McAloone, 2015)	Ecodesign Maturity Model (EcoM2)	manufacturing companies
26	Business Models for S.PSS	(Mont, 2001)*	PSS Development Model and Methodology	Utilities, companies producing or managing chemicals, durable customer products
27		(Geum and Park, 2010)	Technology roadmap for PSS (TRPSS)	Any S.PSS
28		(Herzog et al., 2014)	Risk management in the early phase of IPS ² design	Industrial Product-Service Systems
29		(Chen and Chiu, 2014)	A value creation-based business model for customized product service system design	Any S.PSS
30		(Chiu et al., 2015)	A systematic methodology to develop the business model of a PSS	Any S.PSS
31		(Corti et al., 2015)	Service-oriented business models for AM manufacturers using Osterwalder and Pigneur's business model canvas	AM
32	Service design for S.PSS	(Aurich and Fuchs, 2004)*	ELIMA (Environmental Life-Cycle Information Management and Acquisition for consumer products) project	Manufacturing industry
33		(Aurich et al., 2006)	Life cycle-oriented design of technical PSS	Technical PSS
34		(Xing et al., 2013a)	PSS for community social-economic transformation	Community transformation
35		(Liu et al., 2014)	Service-dominant logic-based integrated product-service system business model	Service-dominant integrated product-service system
S.PSS Modeling and Simulation Supports				
36	S.PSS modeling & simulation	(Garetti et al., 2012)	Life Cycle Simulation (LCS)	Any S.PSS
37		(Alix and Zacharewicz, 2013)	–	Any S.PSS
38		(Hallstedt et al., 2013)	–	Aerospace industry
39		(Komoto and Mishima, 2013; Komoto et al., 2005)	Life cycle simulation (LCS)	Any S.PSS
40		(Maisenbacher et al., 2014)	Agent-Based Modeling for Supporting PSS Development	Any S.PSS
41		(Rondini et al., 2014)	Simulation approaches for designing S.PSS	Customer-oriented PSS

Sr. No.	Category	Reference	Name/ Aim of the Design Support/ Project Name	Target Sector
42		(Rondini et al., 2015)	Simulation approaches for evaluation S.PSS	Customer-oriented PSS
43		(Shokohyar et al., 2014)	A model for integrating services and product EOL management in S.PSS	Product-oriented PSS
44		(Grüneisen et al., 2015)	Modeling cycle networks of the innovation process of PSSs for supporting the management of interdisciplinary innovation projects	Any S.PSS
45		(Wrasse et al., 2015)	Simulation of PSS Piloting with Agent-Based Models	Micro Energy Supply Information System
S.PSS Evaluation Supports				
46	Evaluation of S.PSS	(Halme et al., 2006; Halme et al., 2004)	-	Household services
47		(Tasaki et al., 2006)	A method for evaluating a leasing system for electronic and electric equipment	Electronic and electric equipment
48		(Tonelli et al., 2009)	Analysis, Development, Verification, and Proposal (ADVP) Framework for PSS strategy Evaluation	Small and medium enterprises
49		(Hu et al., 2012)	Fuzzy Delphi method	Any S.PSS
50		(Lee, S. et al., 2012)	Triple Bottom Line - based System Dynamics approach	Any S.PSS
51		(Chun et al., 2010)	Total Performance Analysis (TPA)	Any S.PSS
52		(Vogtländer et al., 2002)	Eco- costs/Value Ratio (EVR) model	Any S.PSS
53		(Zhang et al., 2011)	IDEF0 systems modeling tool	Any S.PSS
54		(Peruzzini et al., 2013a, b, c)	Methodology to assess PSS's sustainability by modeling an integrated lifecycle, defining impact categories and KPIs, and evaluating all the partners' contributions.	Extended enterprises, Virtual Manufacturing Enterprises
55		(Xing et al., 2013b)	A sustainability-oriented multi-dimensional value assessment model for PSS development	B2C offerings
56		(Abramovici et al., 2014)	PSS Sustainability Assessment and Monitoring framework (PSS-SAM)	B2B offerings
57		(Chong et al., 2014)	Comparing LCC with LCA to assess PSS sustainability	Temporary building
58		(Waltemode et al., 2012)	Life cycle-oriented quality assessment of Technical PSS	Technical PSS
59		(Chen et al., 2015)	PSS solution evaluation considering sustainability	Hybrid uncertain environments
60		(Chou et al., 2015)	A concept of S.PSS efficiency is proposed to explore the relationship between PSS value and the sustainability impact	Any S.PSS
61		(Copani and Rosa, 2015)	DEMAT: sustainability assessment of new flexibility-oriented business models in the machine tools industry	Machine tools industry
62		(Mourtzis et al., 2015)	Performance Indicators for the Evaluation of PSS Design	Any S.PSS
63		(Pan and Nguyen, 2015)	Identify the key performance evaluation criteria for achieving customer satisfaction through Balanced Scorecard (BSC) and	Manufacturing companies

Sr. No.	Category	Reference	Name/ Aim of the Design Support/ Project Name	Target Sector
			Multiple Criteria Decision Making (MCDM) approaches	
64		(Ziout and Azab, 2015)	PESTLE-based evaluation metrics for PSS	AM
<i>S.PSS Operation Supports</i>				
65	Implementation and diffusion of S.PSS	(Hirschl et al., 2003)	User typology for sustainable consumption	Consumer-oriented PSS
66		(Mont, 2004a)	Framework for analysis of B2C cases	B2C offerings
67		(Yang et al., 2004* ; Yang et al., 2009)	ELIMA (Environmental Life-Cycle Information Management and Acquisition for consumer products) project	Consumer products
68		(Lee et al., 2005 ; Lee et al., 2007)	Integrated Manufacturing and Product Services System (IMPSS)	Electronic product manufacturers
69		(Briceno and Stagi, 2006)	The role of social processes like participatory and community-based strategies for sustainable consumption	Consumer-oriented PSS
70		(Ceschin, Fabrizio, 2013 ; Ceschin, 2015)	S.PSS - Strategic Design and Transition Studies	Any S.PSS
71		(Chen, 2014)	Introduction strategies of service-oriented S.PSS for the transformation and upgrading of small and medium manufacturers in China	Small and medium enterprises in China
72		(Heilala et al., 2014)	Eco-Process engineering system (EPES)	Virtual factories, extended enterprises
73		(Lelah et al., 2014)	Scenarios as a Tool for Transition towards S.PSS	Small and medium enterprises
74		(Krucken and Meroni, 2006)	Communication support material (CSM)	Any S.PSS
75		(Bisiaux et al., 2015)	The business model, a tool for transition to sustainable innovation	Any S.PSS
76		(Byers et al., 2015)	Using portfolio theory to improve the resource efficiency of invested capital	Any S.PSS
77		(Gupta et al., 2015)	Multi-Objective Genetic Algorithm to find the optimized taxes for some possible combinations of the sale price and number of units to be manufactured	Manufacturing industry
78		(Mylan, 2015)	Understanding the diffusion of S.PSS: Insights from the sociology of consumption and practice theory	Any S.PSS
79	(Rasouli et al., 2015)	A Dynamic Capabilities Perspective on Service- Orientation in Demand-Supply Chains	Service-Oriented Demand-Supply Chain	
80	(Sundin et al., 2015)	Sustainability indicators for small and medium-sized enterprises in the transition to provide S.PSS	Small and medium enterprises	
81	(Reim et al., 2015)	S.PSS business models and operation-level tactics	Any S.PSS	
82	(Liedtke et al., 2015)	User-integrated innovation in Sustainable LivingLabs: an experimental infrastructure for researching and developing S.PSS	Consumer-based S.PSS	

*Identified from ([Maxwell et al., 2006](#))

Appendix 4

Application of MSDS methodology and ICS toolkit to re-design a 2WT based BP

Here we present the details of MSDS methodology and ICS toolkit application to re-design of a 2WT based BP for the South of Bangladesh.

A4.1. Strategic Analysis (1)

Here the goal is to secure contextual information, examine it for the context of sustainability, and set sustainability-oriented design targets. The five processes to achieve the same are: (1.1) *project promoter analysis and definition of intervention context*, (1.2) *reference context analysis*, (1.3) *system carrying structure analysis*, (1.4) *analysis of cases of excellence for sustainability*, and (1.5) *analyze sustainability & determine priorities for the design intervention concerning sustainability*. The following subsections elaborate on the work done under each of these processes.

A4.1.1. Project promoter analysis & definition of intervention context (1.1) + Reference context analysis (1.2)

The process (1.1) aims to define the design intervention's scope and analyze the project promoters. The process (1.2) aims to analyze the reference context by studying its production and consumption system, the competitors, and clients. [Figure A4. 1](#) diagrammatically presents the two processes, their sub-processes, the expected results, and the tools.

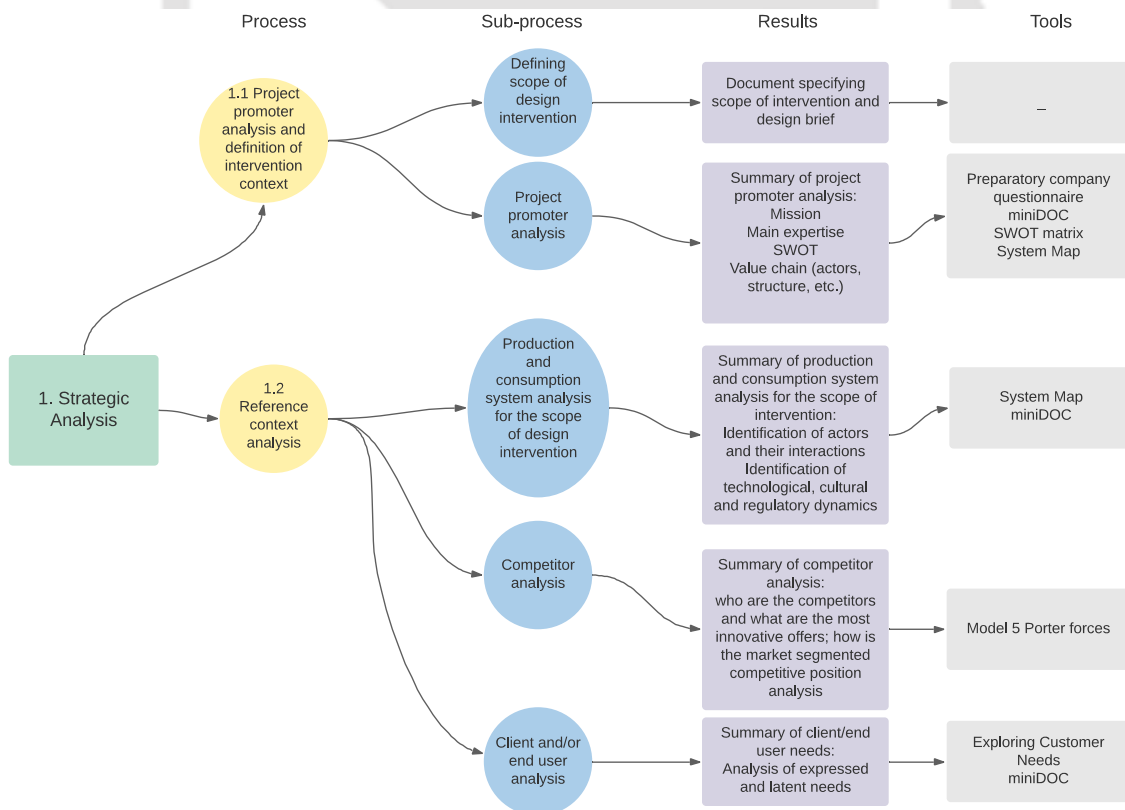

Figure A4. 1. Strategic analysis – (1.1) Project promoter analysis and definition of intervention context, (1.2) Reference context analysis. Source: (Vezzoli et al., 2014).

Identification of stakeholders, their roles, interests, and concerns

We initiated strategic analysis by identifying the following critical stakeholders, their roles, interests, and concerns. [Figure A4. 2](#) shows the stakeholder map, divided into two groups, providers and customers.

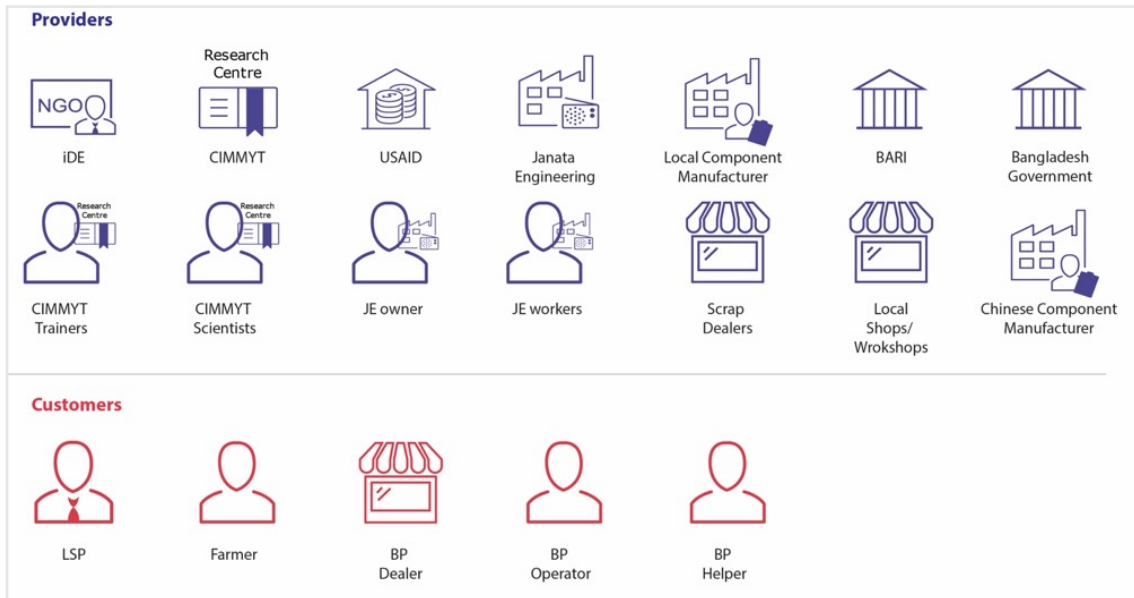

Figure A4. 2. System Map of Stakeholders

The key roles, interests, and concerns of the stakeholders were as follows:

8. **iDE-B** is a country program of the international non-profit iDE, headquartered in Denver, USA. IDE-B was the first Country Program, established in 1984. It pioneered the development of private sector supply chains of micro-irrigation technologies that provided small and marginal farmers with affordable irrigation. It also facilitated different approaches for strengthening the rural market system to increase farmers' market access, productivity, and, ultimately, income. In this project, they coordinated the design, development, training, manufacturing, and marketing of BP along with CIMMYT. It was concerned about the low quality of BP and its lack of sales in the market. To achieve the sales target in collaboration with CIMMYT, they wanted to develop and start manufacturing a robust BP quickly.
9. **CIMMYT** is a non-profit research and training center that aimed to improve maize and wheat's agricultural yield. They coordinated the design, development, training, manufacturing, and marketing of the BP along with iDE-B. They were also concerned about the low quality of the BP and the fact that it is not selling in the market. To achieve the sales target with iDE-B, it also wanted to develop and start manufacturing a robust BP quickly.
10. **JE**, under the proprietorship of Mr. Oli Hujur, took the initiative to replicate the D-BP design presented to them by CIMMYT and iDE-B. In the future, he might be one of the key manufacturing partners for not only BP but also other AM promoted by CIMMYT and iDE-B. JE's main concerns were to make the BP sturdier, earn profits through the sale of BP and its spare parts, gain repeat business orders for this and other AM, meet production demands, create molds for mass manufacturing, and ensure a better quality of production. The proprietor was strongly motivated towards making a positive impact on the growth of his motherland.
11. The **farmers** had two possible roles to play in the system, own a BP themselves and offer its services to other farmers or hire its services from an LSP. During a discussion session with five farmers in Chuadanga and five in Khulna, we noticed that the farmers were very enthusiastic about the method, bed planting, and made beds manually. They were concerned with BP's unreliable

seeding. Thus, they wanted a BP to make beds effectively (minimum viable product) while seeding manually. They were happy that BP could make their entire plantation related activities cheaper and independent of labor's timely availability.

12. The **operators** were farmers, LSPs, or operators employed by the farmers or LSPs. We interviewed three operators in Chuadanga, of which two were operators only while one was a farmer too. In Khulna, we interviewed three LSPs, and they were operators too. Operators operate, repair, and maintain BP. Their main concern was the weight of the BP, which made it physically strenuous to operate it. They reported shoulder and hand pain and, at times, contracted fever the day after operating it. They would operate it only on alternate days. A large number of adjustment possibilities on BP made it challenging to understand the best-suited setting combination. They were unaware of agronomic practices and unable to infer relationships between soil conditions, seeds, and BP settings. They were also not well-trained in BP usage, leading to operational problems.
13. We interviewed 3 **LSPs** in Khulna. They are supposed to buy the machine and work as operators or hire operators. The current LSPs had not bought the machine but had been provided with one under the CSISA-MI project. LSP paid for the BP maintenance and its running cost. Hence, their main concern was a robust BP whose spare parts are locally available. They wanted BP to have two modules, one for constructing beds and the second for bed planting. This arrangement would allow them to make purchase choices as per their requirement. In addition to the targeted crops of wheat, maize, green gram, and mustard, BP should handle sunflower too, as the region had a big market. At this moment, BP cannot handle sunflower beds and has no seed meter for it. One operator had designed a wooden seed meter for sunflower. They were concerned about BP's low quality, constant breakdowns, no local spare parts availability, and lack of farmers' trust in it. These contributed to their hesitance in buying BP.
14. We interviewed a BP **dealer** in Chuadanga. The dealer served as the link between the manufacturer and the LSPs. He promoted the BP in his region. His interest lay in selling good quality machines and thereby earn credibility amongst the buyers to sell more AM. He was concerned about the low quality and reliability of the current BP (2 BP were sold but returned soon after), due to which his reputation in the market had suffered. He also mentioned that BP looks more like a test rig and less like a desirable product. That, according to him, had also played a role in its market failure.

System Map

Next, we mapped the energy (material, information, money, labor performance) flows of the bed planting system ([Figure A4. 3](#)). The BP project was funded under CSISA-MI by USAID and was commissioned to CIMMYT and iDE-B. The partnership of providers presently consisted of CIMMYT, iDE-B, and JE. The BP ownership was to be transferred to LSPs by the partnership of providers through a dealer. The LSPs, operators, and farmers were trained in the BP operation by CIMMYT. In the absence of spare parts supply chain, the LSPs depended on local shops and workshops. JE owner reverse-engineered the BARI D-BP with CIMMYT and bagged orders for 50 S-BP from iDE-B. JE employed unskilled workers and trained them on the job to manufacture, assemble, and repair BP. Since none possessed professional manufacturing training, quality control was non-existent. Some of the BP components, like rotary blades, were imported from China and then modified in-house by JE. JE bought parts like die-cast components, plastic seed meters, and fasteners from local manufacturers.

Problems and their causes - BP design & the bed planting system

The two brands of 2WT most popular in the country were Dongfang and Sifang, both Chinese manufacturers. The 2WT were available in mostly 9 HP, 12 HP, and 13 HP variants. BARI had done pioneering work in the country in the field of 2WT based AM development. [Hossain et al. \(2010\)](#) had developed a Dongfang 2WT based BP (D-BP). In the South of Bangladesh, Sifang 2WT was the most common. Mr. Oli Hujjur reverse-engineered the BARI D-BP and converted it into a Sifang make of 2WT

based BP (S-BP). The D-BP was a more robust and less problematic product than the S-BP as the former had gone through an iterative technical design process at BARI. The S-BP was released in the market without such extensive testing and design iterations. Also, S-BP operators were much less trained and hence struggled with it. The operators of D-BP who were extensively trained by BARI and had many years of experience operating the D-BP were better at handling the machine and reported better BP performance. Also, certain issues arose due to the make of the 2WT for which the BP attachment was built. The difference between the Sifang and Dongfang make 2WT was in their weight distribution. The Sifang was heavier on the rear due to the engine position. Thus, the ergonomic difficulties of operating the S-BP were much higher (Figure A4. 9). The earlier BP versions had a fertilizer metering and dispensing sub-assembly, which was not performing the task appropriately and hence removed. The stakeholders expressed that having it would make BP usage more cost-effective. They could save fertilizer by locally applying it around the seed rather than their current hand broadcast methods.

Current System Map Energy Flows

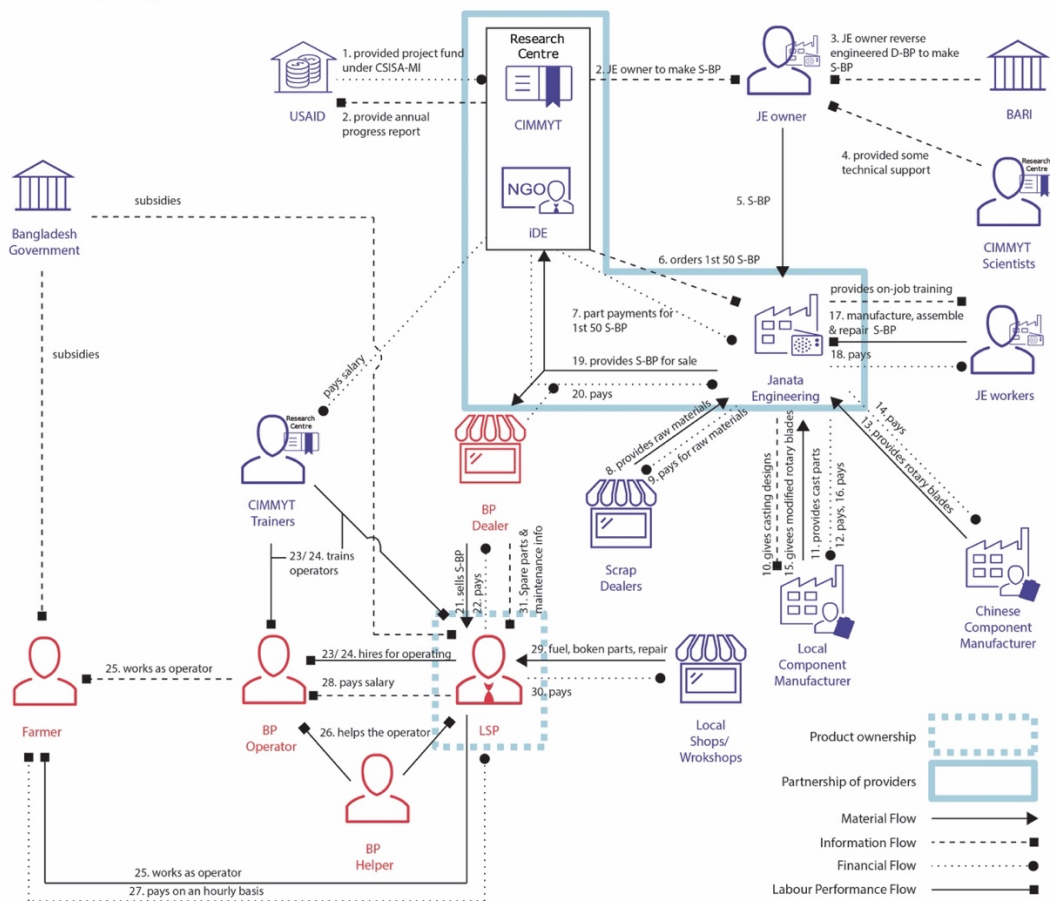

Figure A4. 3. System Map of Energy Flows between Stakeholders

Some farmers mentioned that they had decided to buy BP but had subsequently heard that the Government is planning a subsidy on it. Hence, they decided to wait for it. Some farmers also felt that much free demonstration of BP had been done, and they expect that this trend will continue. Hence, they did not want to purchase it. The stakeholders also mentioned that word-of-mouth had spread regarding the low quality of the BP. Hence, they were skeptical about buying it. We observed that AM ownership was seen as a status symbol. The farmers, operators, LSPs, and the dealers all aspired for tractors and their performance. The 2WT-based BP was looked down upon in terms of status and performance irrespective of the non-viability of tractor operations in their small farms.

An initial assessment of BP shows a pretty good design from an agronomic requirement fulfillment point of view. It achieves plowing, seeding, and bed making. Some manufacturing and material specification redesign was all that was needed to set right the technical issues. The design allowed different setting possibilities (Figure A4.4, Figure A4.5, Figure A4.6, Figure A4.7), an essential feature for it to be useful for agricultural scientists. Scientists could set it in different settings and test the outcome. However, a large number of settings made it confusing and difficult for an illiterate or semi-literate operator. They needed straight – forward instructions and simple interfaces.

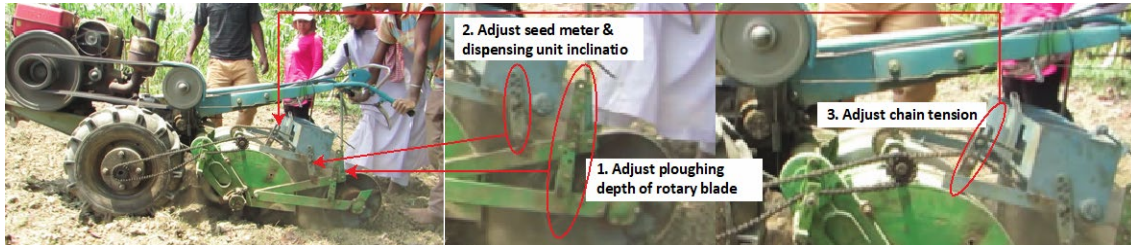

Figure A4.4. Shows the difficulty of comprehending the number of possible combinations for setting the plowing depth of the rotary blades (1) and, based on that, adjusting seedbox box inclination (2). Then the chain tensions need to be adjusted appropriately (3).



Figure A4.5. The bed shaper cone can be set for different bed sizes.



Figure A4.6. Depending on plowing depth, the furrow opener depth hole needs to be selected.



Figure A4.7. The furrow opener can be set anywhere in the given slot.



Figure A4.8. Counterweight in the front to ease lifting the BP (Source: CIMMYT).

During the field tests, we observed that the operator struggled to set the BP on the right combination of settings (Figure A4.4, Figure A4.5, Figure A4.6, Figure A4.7). Also, to ease the BP's lifting at the turns, one would tie up a bag full of sand on the front of the machine (Figure A4.8). The visual impact of that on the on-lookers was a less reliable machine, full of hassles. There were other technical issues. For instance, the seed dispensing was inconsistent, which led to the seeds not falling at the recommended 20 cm \pm 5 cm gap; poor-quality materials and inappropriate manufacturing techniques led to the frequent breakdown of the components and the machine itself. These further reduced the sense of reliance on the machine. On-lookers felt it might be tough to operate the machine,

or maybe the machine is broken or is just a piece of *Jugaad*²⁷. Thus, the machine was perceived as inferior. The farmers and operators kept on comparing its performance to those of tractors and wishing for one.

The economics of bed planting was worked out at 400 Taka (~345 INR) for 1 Bigha (0.1338 ha) of land. From the farmers' point of view, that is very attractive, as manual labor was more expensive. The operator usually takes his sister or wife to help him in operation. Thus, 400 Taka for diesel (transporting the machine to the farm and operation), two operators, machine maintenance, and LSP's return on investment does not appear economically attractive enough for the LSP and operator. This was not recognized as a problem by the LSPs at the research time as they did not buy the machine. They were provided BP by iDE-B or CIMMYT. However, once BP is bought, operated, and solely maintained by LSP, this can become a concern. BP did not have rear wheels. Thus, it had to be transported on a pick-up truck from one village to another, implying additional labor and transport costs.

At the end of each line on the field, the BP was lifted from the rear, rested on the front wheels, and given an 180° turn by holding one clutch ([Figure A4.9](#)). This lifting was repeated very frequently because of the small field size, causing fatigue and pain to the operator. Hence, it was difficult to find operators. Also, it was observed during operations that a lot of soil dust was generated. More dust was generated because operators removed the mudguard to see if the seeds were dispensing or stuck in the delivery pipe. Dust was being inhaled by them and was also getting into their eyes. That might be another reason behind the operators' feeling of physical discomfort at the end of the day. But during on-field interviews and participatory design sessions, they mostly said they were people used to a hard life and not bothered much about dust. None found a reduction of dust as very important in the new design. During the interviews and co-design sessions, some operators wanted weight reduction to be a prime design focus. However, there was also one operator who described the weight as not a significant issue. He had already developed tactics to lift BP more efficiently than the other operators interviewed. He also worked at JE. Due to his daily heavy manual metalwork, he might have developed more substantial hand and shoulder muscles than the other operators.



Figure A4.9. Turning BP at the end of one line on the field.

²⁷ Jugaad Innovation Definition from Financial Times Lexicon - Jugaad is a word taken from Hindi which captures the meaning of finding a low-cost solution to any problem in an intelligent way. It is a way to think constructively and differently about innovation and strategy.



Figure A4. 10. Tons of adjustments and awkward postures needed to achieve the same.

We observed that the operator had to acquire awkward postures ([Figure A4. 10](#)) to do all the setting changes on BP and during on-field repair of components. Again, the operator did not report this as a problem as he was used to such awkward postures during his daily work routine and thought of it as usual. During the assembling and disassembling processes, we observed that BP was not designed for manufacturing and assembly. Also, the components were not optimally designed considering strength and weight. JE's owner was keenly interested in getting guidance on the right material selection, jigs, fixture and mold development, and a design, which was more comfortable and faster to manufacture and assemble. His manufacturing infrastructure was limited to basic machines like drilling and welding machines. None of JE's staff was trained in manufacturing and quality control. They were illiterate or semi-literate and were trained on the job. Once they achieved a certain degree of proficiency, they would leave JE and move to the city or abroad. Other manufacturing units visited faced similar problems as JE or were large for the scale of production required for BP. The market had raw material quality issues. All these posed as challenges and limitations for the scenario.

SWOT Analysis

Subsequently, we conducted a SWOT analysis of the current scenario. The analysis revealed the following:

Strengths

- ◆ iDE-B and CIMMYT had a vast experience of successfully commercializing AM and other base of the pyramid products in South Bangladesh.
- ◆ CIMMYT had a strong team of experienced and well-trained engineers who could train operators.
- ◆ JE had good operational experience in manufacturing AM.
- ◆ USAID funding was available for project dissemination.
- ◆ BP was more economical than manual labor. As it could perform plowing, seeding, basal fertilizing, and bed shaping concurrently, it saved time. Thus, the adoption of BP is likely to be high.
- ◆ BP can be used to sow a wide range of seeds and also for making just beds. It can also be used for reshaping of beds with certain modifications in the design. Thus, the potential market is large.

Weaknesses

- ◆ Sifang 2WT had a different weight distribution than Dongfang 2WT. Hence, the current design replication strategy was not working.
- ◆ “One design fits all situations” strategy was used. Hence, BP would usually fail under many conditions.
- ◆ The machine was well suited for agricultural scientists or engineers who would like to put the machine under various depth or width configurations and conduct experiments. When given to

the illiterate or semi-literate operators, the same number of adjustment possibilities ended up in the wrong settings. That led to improper results or BP break down.

- ◆ The BP looked more like a test rig rather than an aspire-able product. BP was not ergonomically designed considering manufacturing, use, repair, and maintenance phases. These weaknesses were due to a lack of designers in the development team.
- ◆ Several problems arose due to a lack of quality manufacturers to collaborate. For example, plastic seed meters were being used, which would warp under heat, leading to small seeds getting stuck in them, leading to meter break down. Furthermore, the mold was handmade, and hence the meter teeth were not uniform, leading to seed misses or extra seeds falling in. The rotary blades were imported from China, modified, and heat treated. Since no appropriate heat treatment facility for the given volume of production was available, assuring the blades' quality and life was challenging.
- ◆ Many of BP's current issues were due to stakeholders' knowledge deficiencies regarding manufacturing, operation, servicing, maintenance, and operational intricacies related to agronomic practices and procedures.
- ◆ JE owner and staff did not have formal knowledge of engineering and manufacturing. Hence, most parts were over-designed or ill-engineered and not designed, keeping in mind the ease of manufacturing, assembly, and repairing. They eliminated parts from BP without understanding the reason for their presence. They did not follow quality control measures and standardization of parts and components. Thus, the manufacturing quality was the biggest weakness of the consortium of providers.
- ◆ The manufacturing setup of JE consisted of basic machines like welding and drilling machines. Thus, manufacturing was mostly manual. The staff was not formally trained in manufacturing. As soon as one achieved a certain dexterity level at manufacturing, he left JE for better opportunities in the city or abroad. Hence, JE had to work with an unskilled and changing workforce mostly.
- ◆ Lack of adequate training to the operators led to improper usage and regular break downs of the machine.
- ◆ The trust of consumers in BP was low due to its constant breakdowns and lack of spare parts and maintenance ecosystem.
- ◆ Due to back-heavy design, BP was challenging to maneuver in the field, resulting in severe discomfort for the operators. Hence, people were hesitant towards becoming operators.
- ◆ Too many free demonstrations led to a feeling that the same will continue, and there was no need to buy the machine.
- ◆ BP's service cost was economical for the farmers, but not for the operators and the LSPs. BP had to be lifted and transported on a tempo from one village to another. That was an additional cost, not accounted for in the costing.
- ◆ Too many versions of the machine existed in the market-leading to confusion between versions. Proper documentation and serial numbering of parts were not done. Hence maintenance or spare parts providing was tough.

Opportunities

- ◆ The market for bed planting was ripe, and farmers were already practicing the same with manual labor. They were looking for an efficient and robust BP which can plant a wide variety of seeds and simultaneously plow, seed, apply fertilizer, and make beds. They were also looking for additional possibilities like bed shaping and weeding.
- ◆ 2WT was popular in the region. 2WT based implements are well suited for small farms, and the region mostly has small farms.
- ◆ AM on hire was a well-accepted form of service.
- ◆ Manual labor was becoming scarce and expensive. Hence, farmers were seeking AM.
- ◆ BARI had already put in years of R&D into the area and came up with the D-BP. Hence the new design, S-BP, could be designed with much lesser effort.
- ◆ Government subsidy for the purchase of such equipment was also a possibility in the country.

Threats

- ◆ Farmers aspired to use, hire, and own tractors.
- ◆ The market lacked appropriate raw material for making a robust design or serving as inputs while running it. For example, fasteners available in the local markets were of low quality, leading to constant break down. The fertilizers available were hygroscopic and hence clogged the metering unit.
- ◆ The life of the Dongfang and Sifang 2WT for agricultural use was 3-5 years. Once the current 2WT is no longer useful, the operator will have to buy a new one. Since the BP is designed as an attachment to the existing design of 2WT, it may not fit on to the new model.
- ◆ The success of BP largely depended on the quality of the rotary blades. With the current production volume, no manufacturer with proper heat treatment facilities was ready to manufacture them. Hence the breakdown of blades will remain as a deterring issue.
- ◆ To reduce the machine's weight and make it more ergonomic, thinner gauge sheet metal and plastic components were required. Thinner gauge sheet metal was not available in the country. Plastic component manufacturing had scale-of-production issues.
- ◆ Word of mouth had caused substantial damage to the product already.
- ◆ Bed Planting causes a lot of soil disturbance and hence is not regarded as a soil-friendly practice. A stress on conservation agriculture can influence farmers to switch to it, eliminating the bed planting market.

Scope for design intervention

Post the promoter and reference context analysis, the scope for design intervention was defined. From the research mentioned above, the need to shift the attention from designing a BP to designing bed planting as a PSS was apparent. This PSS involved BP, the product strategy, operator and manufacturer training, and a supporting marketing strategy. The market definition for the prospective PSS was co-defined by all stakeholders.

Market definition of bed planting PSS

Bed planting as a PSS will target 2WT based BP with a robust and well-engineered BP, manufactured in Bangladesh by training local small manufacturers. Thus, interested but inexperienced manufacturers can also become part of the PSS. BP design will be copyleft for any manufacturer interested in using the same. BP will be made as a modular system to cater to different types of markets and provide the opportunity to purchase the modules as increments to the base model. The iDE-B and CIMMYT team will use their current USAID funding under the CSISA-MI project to train the BP manufacturers and operators. Since word-of-mouth is a vital mode of advertisement for this type of product in the region, attempts will be made to tap its advantages and avoid the disadvantages. To avoid the disadvantages, the current lot of 50 reverse engineered BP will not be released into the market. The spare parts market and infrastructure will be built simultaneously for the success of BP. The market definition is diagrammatically represented in [Figure 5.6](#).

Unit of satisfaction

We used the means-end analysis to map the PSS values desired by the stakeholders. That helped identify the “unit of satisfaction” for the PSS as an aspire-able bed planting system. The six types of values in the means-end analysis are *concrete attributes*, *abstract attributes*, *functional consequences*, *psycho-social consequences*, *instrumental value*, and *terminal value*. The “aspire-able bed planting system” is the *terminal value* of the PSS. The “aspire-able” is achieved through the four *instrumental values* in this case: “employment and income generation,” “efficient agriculture,” “drudgery reduction,” and “promotion of local small-scale manufacturers” ([Figure A4. 11](#), which shows a section of the means-end analysis). “Drudgery reduction,” for example, can be accomplished here through the following five *psycho-social consequences*: “growing up the economic ladder,” “increased social status,” operators feeling “I can do

it easily,” “women can also become operators” and “avoid the unpaid labor of BP helper.” The *functional consequence* of, say, “avoiding unpaid labor of BP helper” is a BP designed for effective and efficient use by one person. To achieve that *functional consequence*, the *abstract attributes* required are “ease of turning BP at the end of a row” and “reducing the need for constant seeds and fertilizer filling.” Finally, we translate all the *abstract attributes* into *concrete attributes*, i.e., design specifications for BP. The product specification, drawn out from the above-mentioned *abstract attributes* is, to redesign the BP’s weight distribution so that its center of gravity moves towards its front. That can be achieved by various means like incorporating a seed and fertilizer storage box. The service specification drawn is designing a training and certification program for the operators that trains them in proper techniques for operating BP. [Figure A4. 11](#) shows the means-end analysis section described here, and [Figure A4. 12](#) shows the complete analysis.

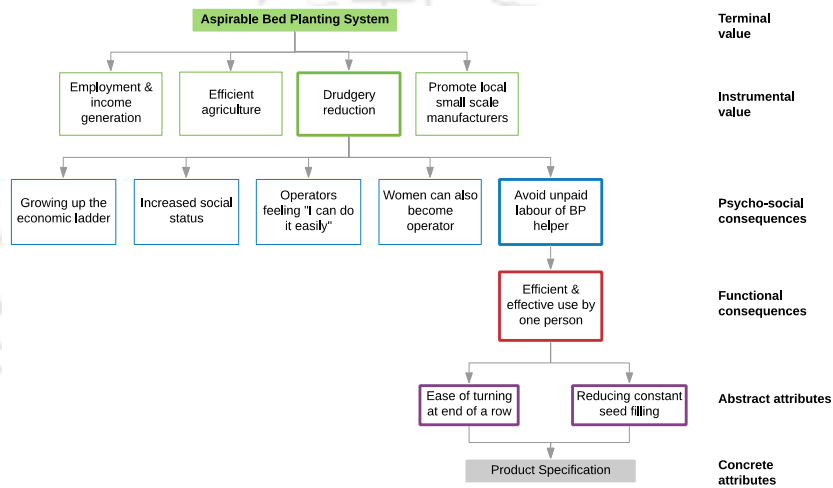

Figure A4. 11. A section of the means-end analysis.

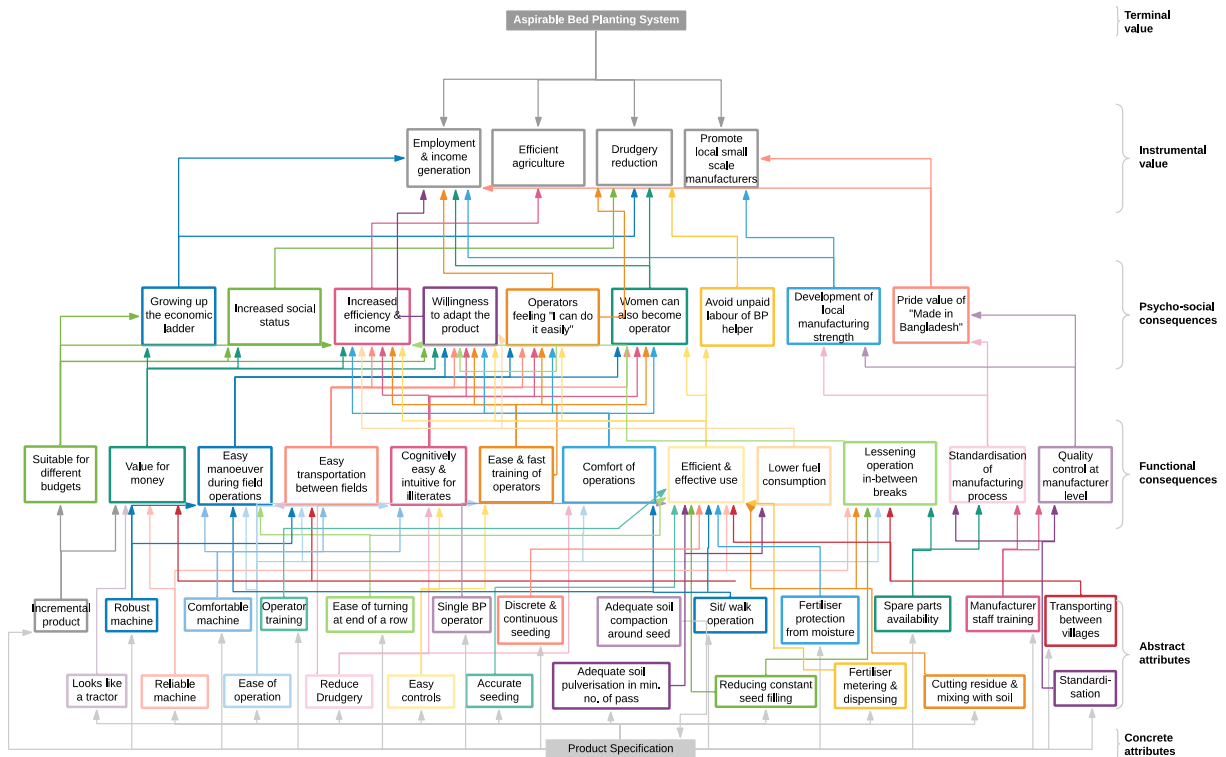

Figure A4. 12. Functions are mapped according to the six types of values listed in the means-end analysis.

PSS design specification

The PSS design specification, as obtained by the means-end analysis, is as follows:

To design a bed planting PSS which

Must-be Quality (Basic)

- ◆ Has a modular BP with add-ons.
- ◆ Uses, as far as possible, standard components for manufacturing BP and provides essential spare parts inventory. The most frequently required spare parts will be provided along with the BP as a package.
- ◆ Pulverizes soil sufficiently and compacts it around the seeds adequately.
- ◆ Achieves accurate precision and mass flow seeding.
- ◆ Is a reliable and robust machine.
- ◆ Is easy to maneuver (lift and turn) in the field and transport from village to village.
- ◆ Can be transported with ease from one village to another.
- ◆ Is cognitively easy and intuitive in operation for even illiterates.
- ◆ Has a visual operation guide for operators.
- ◆ Has a training module guidelines for operator training.
- ◆ Has a manufacturer's manual, detailing material and manufacturing specifications and assembly process.

One-dimensional Quality (Performance)

- ◆ Has the possibility for fertilizer metering and dispensing.
- ◆ Has the possibility to perform bed planting while seated.

Attractive Quality

- ◆ Is an aesthetically aspire - able product.
- ◆ Generates less dust.
- ◆ Consumes less fuel.

Features to be sold as an add-on to reduce the cost of the base model and provide LSP with options

- ◆ Has a seating arrangement plus a rear wheel.
- ◆ Has a fertilizer metering and dispensing unit.
- ◆ Has a seed and fertilizer storage unit.

The results of the processes (1.1) and (1.2), the gaps, and proposed addition are summarized in [Table 5.2](#).

A4.1.2. Product Analysis

(Proposed addition to fill product design focus gap) (1.3)

To bring product design focus to MSDS methodology, the product analysis process is introduced as the third process under *Stage 1: Strategic Analysis*. This section presents an analysis of the existing product from an engineering perspective, uses the ICS toolkit aided environmental analysis and design priority setting. [Figure A4. 13](#) diagrammatically presents the process, its three sub-processes, the expected results, and the tools.

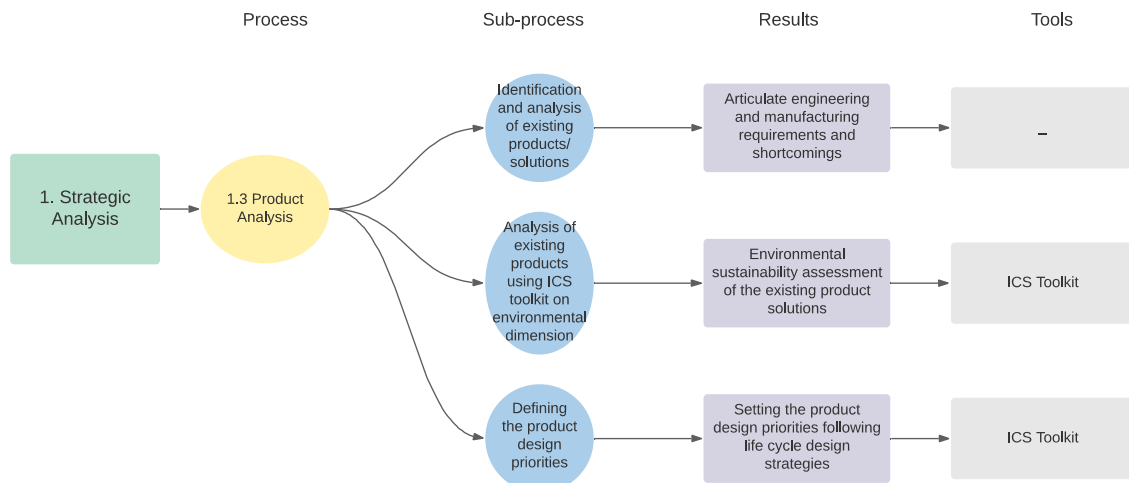

Figure A4. 13. Strategic analysis – (1.3) Product analysis

A4.1.2.1. Identification and analysis of existing products/ solutions

We analyzed the D-BP and the S-BP in the process (1.3). During field trials and discussion with experts and grassroots stakeholders, we observed that:

- ◆ The D-BP created better beds as compared to S-BP.
- ◆ The Dongfang had a slower forward speed than Sifang. Operators felt that the whole bed planting activity was slow and must be due to some product problems. This misconception needs to be dealt with during training, and operators need to be informed regarding optimum speed for bed planting. The recommended speed for bed planting was 1.5 km/hr. Nevertheless, this varied based on soil texture or properties, moisture content of the soil, residue remains, and plot size. These aspects need to be dealt within the training program.
- ◆ D-BP under similar soil conditions generated less soil dust in the air as compared to S-BP due to its part configuration. D-BP was more compact than S-BP. Hence, the soil generated hits BP parts and falls rather than generating soil dust in the air.
- ◆ Operators, farmers, and CIMMYT field engineers reported that Sifang 2WT had a longer life than Dongfang 2WT. The former also had a better resale value. After three years of usage, it sold at around 50,000 Taka (~43,000 INR) while the latter at around 20,000 Taka (~17,000).
- ◆ Sifang 2WT is heavier on the back than Dongfang 2WT and hence, needed an 82-84 cm long belt (default belt is 78 cm) to shift the engine and the weight forward. The belt cost around 300 Taka (~260 INR). This belt could reduce the operator's effort in lifting the machine while turning it. However, the operators showed reluctance in buying it as an add-on. Hence, it was advised to provide this belt along with the BP.
- ◆ BP has four sub-assemblies ([Figure 5.3](#)), through which we present the product analysis next.
 - ◆ Tine unit – rotary blades
 - ◆ Bed shaping unit
 - ◆ Seed metering and dispensing unit
 - ◆ Fertilizer metering and dispensing unit

Tine unit - rotary blades

The rotary blades help to cut and pulverize the soil. Two types of rotary blade arrangements on the shaft were observed in the field: (1) Rotary blades arranged 180° apart on the shaft ([Figure A4. 14](#)); (2) Rotary blades arranged 120° apart on the shaft ([Figure A4. 15](#)). Visual examination of the soil pulverization and bed formation quality revealed that the rotary blades were more efficient when arranged 120° apart. CIMMYT and BARI experts agreed to this too.



Figure A4. 14. 180° Apart rotary blades arrangement on the shaft.

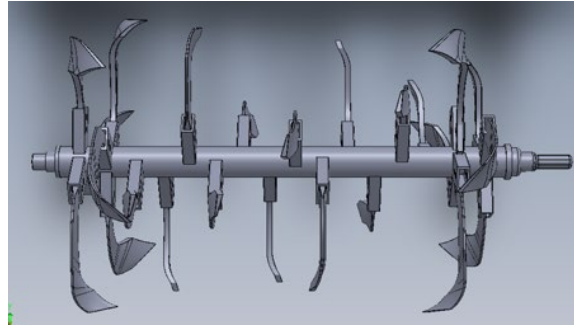

Figure A4. 15. 120° Apart rotary blades arrangement on the shaft.

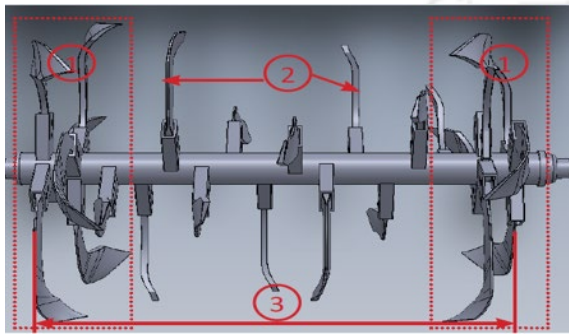

Figure A4. 16. 1: Large rotary blades; 2: Small rotary blades; 3: Tip to tip distance between the blades = cutting width of the blades.



Figure A4. 17. 4: The larger blades tend to bend or break at this point.

The rotary blades shaft had two types of rotary blades. The blades on the edges were large, while those in the center were smaller (Figure A4. 16). The larger blades pulverized the soil on the edges. Those are used on the edges, as the intensity of hitting required at the edges is higher. That pulverized soil will then be lifted to form the bed. Seven large blades were present on both edges of the shaft for the 120° configuration. The ten smaller blades in the 120° configuration center helped pulverize the soil in the bed's center. The seeds are planted in this area. The blades were given a spiral arrangement on the shaft to improve the efficiency of pulverization. The field needed to be plowed before using BP. BARI recommendations for plowing the field before bed planting were as follows:

- ◆ For sandy loam soil, one pass
- ◆ For clay loam soil, two or three passes

The number of passes will also depend on the moisture content of the soil. In case of optimum moisture, one pass will be sufficient. The tip-to-tip distance between the two extremes' blades was 57 cm (Figure A4. 16, label 3). This arrangement will produce a soil pulverization of length 58-59 cm. BARI recommended a tip-to-tip dimension of 58-59 cm to achieve a 60 cm bed. To shape the bed, the bed shaper length should be set at 58 cm. The bed shaper and the scrapper should be set within the blades' cutting width (Figure A4. 20 and Figure A4. 21). The problems observed were as follows:

- ◆ Rotary blades shafts with 180° apart tines had gone into the market. These were not very efficient. The science behind the tine arrangement was not known to JE, causing confusion.
- ◆ The blades bent (Figure A4. 17, label 4) after 3-4 hectares of operation in hard soil. Once bent, even if it is straightened, it did not have the strength to continue. This happened as proper hardening of the blade was not done after straightening.

- ◆ The larger blades tended to bend or break because JE bought them from China and modified them through local manufacturers who did not possess a controlled heat treatment facility to harden the blades.
- ◆ The blades were not sharpened to the right degree by JE. Also, while in use in the field, no sharpening of blades was undertaken. JE reported sharpening blades for its customers once a year in case they brought them to the workshop.
- ◆ Large chunks of soil were being generated by the blades, leading to inadequate soil compaction around the seed. This created an inadequate growing environment for the seed.
- ◆ Due to low quality, the nuts securing the blades to the blade holder came out.
- ◆ Conflicting Concern - If the bed center is pulverized very finely, it will get compressed more on the application of irrigation water. Thus, the bed will become shorter in height. Nevertheless, the bed needs to be pulverized and compacted enough in the area surrounding the seed to give it an optimum growing environment.

Bed shaping unit

The bed shaping starts with the scrapper (Figure A4. 19 and Figure A4. 20). The scrapper helps to scrape the pulverized soil and en masse it for bed formation. The scrapper should be placed within the blades' cutting width (Figure A4. 16, label 3). The bed shaper provides the final shape (Figure A4. 21). Bed dimensions, as recommended by BARI, is shown in Figure A4. 18. BARI recommends the bed shaper length should be 1 cm less than the cutting width of the blades. The bed shaper's height should be around 13 - 14 cm to produce beds of 15 cm height. Currently, a height of 11 cm is being used because 13 - 14 cm produces a lot of friction, which is difficult for the 12 HP 2WT to handle. BARI's practice is to set the height at 12 cm to get a 13 cm high bed. The major problems identified are as follows:

- ◆ JE was unaware of the function of the scrapper. Also, JE had set one of the scrapers outside the blades cutting width. Thus, the scrapper was being dragged through unpulverized soil. That increased friction and caused damage to the scrapper. JE and the operators, thus, thought it was unnecessary and removed it.
- ◆ It was observed that operators were mostly unaware of the bed shaper length and position with respect to the blades. Thus, this aspect was not maintained, leading to inappropriate bed formation and damage to the bed shaper edges as it was being dragged on unpulverized soil. It also reduced machine efficiency due to frictional losses.
- ◆ The blades were not centrally aligned with the BP in the existing design, while the bed shaper was centrally aligned. That created confusion in aligning the bed shaper with the blades.

Thus, the current issues arose, majorly because the operator was not aware of the points mentioned above. Adequate training and design modification (so that the bed shaper and scrapper cannot be set beyond the cutting width) can resolve this. The blades' cutting and pulverization efficiency need improvement to attain 15 cm high beds, and the bed shaper's height increased.



Figure A4. 18. BARI recommended bed dimensions.



Figure A4. 19. Scrapper



Figure A4. 20. Scrapper fixed to the BP.



Figure A4. 21. Bed Shaper (Label 5).

Seed metering and dispensing unit

Seeding can be done either as continuous as in wheat, till, mustard, green gram, sesame, or precision (at fixed interval) as in maize and sunflower. The seed meter controls the seed rate. The dispensing unit controls the line-to-line distance and seed depth. These parameters, as recommended by BARI, for different crops, are summarized below in [Table A4. 1](#). [Figure A4. 22](#) shows the seed metering plate, holder, and the dispensing outlet on the seedbox. [Figure A4. 23](#) shows the seedbox's delivery mechanism to the soil and the furrow opener that opens a furrow for the seed. [Figure A4. 24](#) shows the drive mechanism for the unit.

Table A4. 1. Seed rate, seed spacing, and seed depth for various crops per BARI recommendation.

Crop	Seed Rate (Kg/ Ha)	Seed Rate (Nos./ Ha)	Seed Spacing (in cm)	Seed Dept (in cm)
Maize	20	83,333	60 X 20	6
Wheat	120	–	20	3 - 4
Moong	25	–	30	5 - 6
Sunflower	–	29,555	75 X 45	6
Sesame	5.5 + Rice Husk 11	30	3	

The following problems were observed:

- ♦ BARI scientists observed that more extended plot sizes had better seeding efficiency. Seeding efficiency also depended on the operator training. A ready reference for the operator, which is more visual, was needed as a quick reference for literate, semi-literate, and illiterate operators.
- ♦ The seed-to-seed distance was not maintained in maize because while the seed fell down the seed delivery pipe ([Figure A4. 23](#)), it hit its walls. Depending on the number of hits on its way down, the seed-to-seed distance changed. The seed meter also missed seeds at times and, at other times, dropped two seeds together. As per CIMMYT experts, two seeds falling together (maize and sunflower) can be accepted at around 10% but non-uniform spacing or seed not falling was unacceptable. Non-uniformity of up to ± 5 cm is acceptable in seed-to-seed distance if the recommended distance is 20 cm.
- ♦ Users reported that the plastic seed meter warped under the sun.
- ♦ Wheat or other smaller seeds got stuck between the seed meter plate and the holder gap ([Figure A4. 22](#)), causing a blockage. The gap was created between the two surfaces due to the plastic seed meter warpage and the non-planar surface of the mild steel seed meter holder plate.
- ♦ Users reported that at times when the seed was stuck between the seed meter plate and the holder, the plastic meter cracked. Thus, the users preferred the aluminum seed meter over the plastic one.
- ♦ The seed meter teeth lacked finishing. As the mold for the seed meter was built with hand processes, the teeth were non-uniform. These led to seed misses or picking up of multiple seeds.

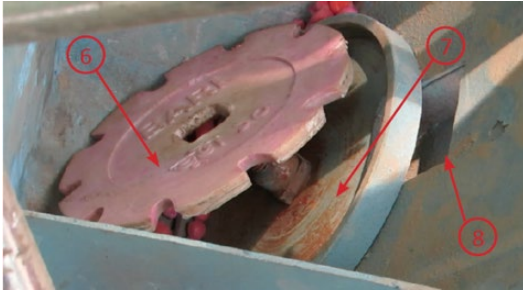

Figure A4. 22. 6 - Seed metering plate 7 - Seed metering plate holder 8 - Seed dispensing from the seedbox occurs from this opening.

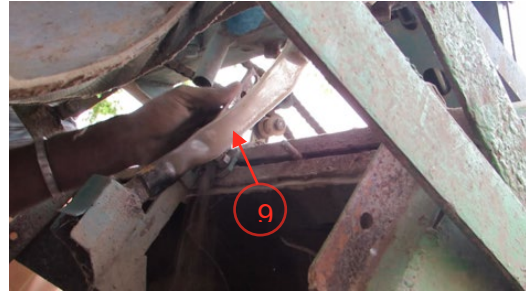

Figure A4. 23. Deformed delivery tube.

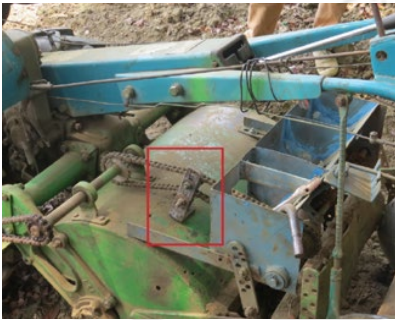

Figure A4. 24. Chain sprocket tension adjustment mechanism for seed meter.



Figure A4. 25. Seed from chamber 1 to 2 is supposed to be manually transferred. Chamber 1 acts as the storage, while chamber 2 is meant for metering and dispensing.

- ◆ The seed delivery pipe was flexible and deformed under the sun ([Figure A4. 23](#)). That created bends in the pipe where the seeds got stuck. The bend also increased seed to seed distance irregularities in case of precision seeding.
- ◆ The seed meter's drive mechanism consisted of a chain and sprocket which slipped out of position from time to time ([Figure A4. 24](#)). That occurred when the chain expanded in length due to aging. It also occurred when the angle of the seedbox was changed. A tension adjustment arrangement was provided to take care of the issue. However, the nut and bolt in the arrangement would loosen due to low quality, and the chain would slack.
- ◆ At times the seed depth was not uniform, leaving some seeds exposed while others at inappropriate depths.
- ◆ The seed was, at times, not covered with soil adequately as the furrow opener accumulated residue ([Figure A4. 6](#)), increasing the furrow size.
- ◆ The soil around the seed was, at times, not adequately pulverized and compacted due to blades not being able to do so. That could occur when the number of passes of plowing done before bed planting was inadequate.
- ◆ BP rocked side to side in soil conditions with larger lumps. Thus, the seed line was not perfectly straight. It also affected the seeding depth uniformity.
- ◆ One seedbox design had two chambers, but one chamber's seeds did not flow into the next ([Figure A4. 25](#)). The operator manually put seeds from one box to another. The repetitive task was time consuming and required awkward postures.
- ◆ That seedbox design, when loaded with seeds, also added weight to the rear. That made the S-BP bulkier to lift at the end of each row. The weight increase did not significantly affect the weight distribution of D-BP.
- ◆ Due to the small size of the seedbox, it needed constant refilling, thereby increasing the operation time. That impact was most significant for wheat, which has a seed rate of 120 Kg per Hectare.

Fertilizer metering and dispensing unit

The fertilizer metering and dispensing unit meters and dispenses basal fertilizers beside the seed while seeding. Applying fertilizers on top of the seed will interfere with seed germination. [Table A4. 2](#) presents the type and quantity of basal fertilizer recommended while bed planting different crops. The following problems were observed:

- ♦ The potash-based fertilizers available were hygroscopic. They turned into a paste within a short time of environmental exposure. That was a hurdle in dispensing it using the current fertilizer box configuration, which did not protect it from environmental exposure.
- ♦ The farmers tended to mix the fertilizers mentioned in [Table A4. 2](#). As a result, the entire mass became hygroscopic and formed clots. The current fertilizer box did not provide for fertilizer segregation.
- ♦ Conflicting Concerns - Fertilizer application through BP was a debatable issue amongst experts involved in the project. However, most experts thought that applying basal fertilizer using BP might be a good alternative. Some experts thought that the fertilizer box could be sold as an add-on component, and a purchaser could choose.

Table A4. 2. Fertilizer (basal quantities) recommendations from BARI.

Crop	Fertilizer (Kg/ Hectare)			
	Urea	TSP	MoP	Gypsum
Maize	185	280	200	212
Wheat	160	160	100	120
Moong	2	90	37	-
Sunflower	60	150	120	130
Sesame	55	130	45	110

Standardization

Due to a lack of formal engineering and manufacturing training, JE owner and staff hardly used standard components or other process standardizations. The common standardization issues observed were:

- ♦ Different sizes of nuts and bolts were used. Thus, many different tools were needed to fix them.
- ♦ Molds for making the seed meter plates, jigs & fixtures for manufacturing various BP components were needed.
- ♦ BP is not designed, keeping in mind the standardization of assembly and repair processes.

A4.1.2.2. Analysis of existing products using the ICS toolkit on the environmental dimension & defining the product design priorities

We analyzed BP using the ICS toolkit on the environmental dimension and defined the design priorities. [Table A4. 3](#) below presents the same.

Table A4. 3. Analysis of existing products using the ICS toolkit on the environmental dimension and defining the product design priorities.

1. Use extension/ intensification (Priority: High)	
Checklist	Is the product/ system a disposable one (used only one time, excluding consumables)? Is the product/ system with short lifespan (excluding consumables)? Is disposable packaging used? Does the product/ system, or some of its parts, tend to wear out quickly? Is the product/ system difficult to be maintained, repaired, and/or upgraded? Does the product/ system tend to be technologically obsolete? Does the product/ system tend to be culturally/ aesthetically obsolete? Does the product/ system remain unused for long periods? Is the product/ system individually used, when it could be shared in some of its parts? Other?

<i>Evaluation</i>	<p>The fasteners (nuts and bolts) and the chain and sprocket mechanisms used were of low quality. The fasteners would loosen or break after a few fastening and unfastening operation. They were also damaged during use. Since they could not be tightened optimally, they loosen, resulting in the break down during usage. The chain elongated during usage and kept slipping, resulting in seed drop misses.</p> <p>The plastic precision seeds metering plates warped in the sun. The small seeds then got stuck in the gap created and caused its breakage.</p> <p>The rotary blades were bought from China, modified with improper heat treatment. As a result, blade life was low.</p> <p>It was not designed considering hard soils. The machine, thus, always broke under such circumstances.</p> <p>The lifespan of the 2WT on which the BP will be built has a short life of 3 - 5 years. Post that, it is not useful for agricultural work.</p> <p>The users wanted to own and use tractor-like powerful machines and thought of BP as obsolete and less capable.</p>
2. Material consumption reduction (Priority: High)	
<i>Checklist</i>	Is the product/system consuming a high quantity of natural resources or absorbing a high quantity of consumables? Is the product/system highly material-intensive (oversized)? Is the packaging highly material-intensive (oversized)? Are there considerable scraps and/or refuses? Other?
<i>Evaluation</i>	<p>The rotary blades were bought from China, modified with improper heat treatment. As a result, blade life was low.</p> <p>The blades erode relatively fast and are a consumable of concern.</p>
3. Energy consumption reduction (Priority: High)	
<i>Checklist</i>	Is the product/system consuming a high quantity of energy? Is the product/system using low efficient technology? Is the product/system unable to adapt energy consumption to different types of use? Is the product/system using low efficient insulation technology? Is there any excessive transportation of the product/system? Other?
<i>Evaluation</i>	<p>The current BP parts were not optimized. The rotary blades and the bed shaper consumed much energy due to their configurations, and the 9 HP 2WT was insufficient.</p> <p>Soil residue blocked the furrow opener. That further adds to the drag for the 2WT, consuming more energy.</p> <p>The 140 Kg weight of BP consumed a considerable amount of energy (diesel). Due to its weight, the operator also had to spend high muscular energy to lift it at each row's end. That caused fatigue and pain for the operator.</p> <p>A counterweight (sandbag) was usually kept on the BP front at all times to ease its lifting, causing higher fuel consumption in carrying dead weight.</p>
4. Material life extension (Priority: Low)	
<i>Checklist</i>	Does some/ all pre-production and/ or production waste end up in a landfill? Does some/ all waste produced in use end up in a landfill? Does the product/ system produce high quantities of landfill waste at the end of service life? Does some/ all packaging end up in a landfill? Other?
<i>Evaluation</i>	<p>The worn-out rotary blades could be put into the recycling process but are not at this moment.</p> <p>Most parts were made of various mild steel grades, which can all be recycled at the end of life. Few plastic parts were present, and they end up in landfills.</p>
5. Toxicity reduction (Priority: Medium)	
<i>Checklist</i>	Do the pre-production and/or production processes release toxic and/or harmful substances for the workers? Are there toxic and/or harmful releases by the product/system means of transport? Is packaging releasing any toxic and/or harmful substances? Does the product/ system release toxic and/or harmful substances for the user? Does the product/ system release toxic and/or harmful substances when disposed of? Other?
<i>Evaluation</i>	<p>The manufacturer has no protective gear for its workers. The welding process releases UV rays, which are very harmful to the workers.</p> <p>It produces soil dust during operation.</p> <p>The 2WT works on diesel and, while operational, release much smoke.</p>
6. Resource conservation/ biocompatibility (Priority: No)	
<i>Checklist</i>	Is any/all of the energy consumed in use produced from exhausting and/or nonrenewable energy resources (e.g., fossil fuels)? Is the product/system produced with exhausting and/or nonrenewable materials? Does the

	product/system use any/only depleting and/or nonrenewable materials in the packaging? Is the product/system potentially compostable produced by any/some non-biodegradable materials? Other?
<i>Evaluation</i>	The 2WT for which BP was built runs on diesel.
	The manufacturing process used welding and drilling machines, which run on electricity from the grid.

The results of the process (1.3) are summarized in [Table 5.2](#).

A4.1.3. System carrying structure analysis (1.4)

We identified the social, economic, and technological macro-trends in this process. [Figure A4. 26](#) diagrammatically summarizes the process, its sub-processes, and the expected results.

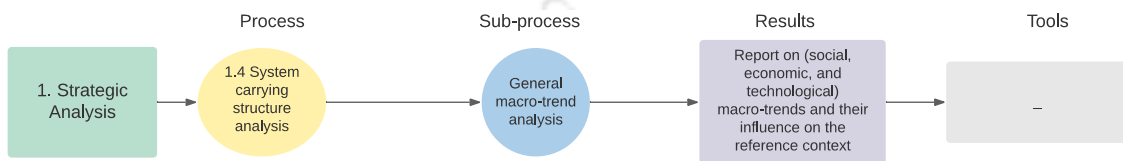

Figure A4. 26. Strategic analysis – (1.4) System carrying structure analysis. Source: ([Vezzoli et al., 2014](#)).

Technological macro-trends

A literature study on AM sub-assemblies, identified in the previous process, was conducted. That led to the identification of best practices, research, and development in the domain. We here present a summary of the design decisions resulting from the process.

Rotary blades ([Goshu, 2007](#))

Aim: To improve the efficiency of soil pulverization and the quality of soil condition thus created.

Results: We identified different blades ([Figure A4. 27](#)) and identified the C-type blade for cutting a clod of soil and L-type for pulverizing the soil as most suitable. The manufacturing process and material composition were studied to identify the right heat treatment process and temperature. Existing soil working devices and their blade arrangement was studied to identify the impact of blade arrangement on soil pulverization. The new proposed design had a combination of C & L type blades in a spiral arrangement. [Figure A4. 28](#) shows the two types of blades currently in use on the BP.

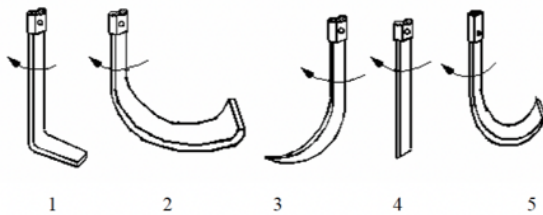

Figure A4. 27. Types of rotary blades.

- 1- "L"-shaped type
- 2- Backward curved tip twist ("C"-shaped)
- 3- Hock ("Pick"-type) blade
- 4- Straight ("I"-shaped) blade
- 5- "J"-shaped (Scoop)

Source: ([Goshu, 2007](#))



Figure A4. 28. The large and small blade, used in the current BP.

Precision seed metering (Murray et al., 2006)

Aim: To select single seeds from the seed lot and deliver them using the metering and dispensing mechanism at a preset time interval for large seeds like maize and sunflower.

Results: We studied different precision seed metering mechanisms (Figure A4. 29), both mechanical and electronic. As a low-cost solution was desirable, we designed a mechanical seed meter (inclined plane type, Figure A4. 30) for maize. We also studied the influence of the meter plate angle and created an appropriate design.

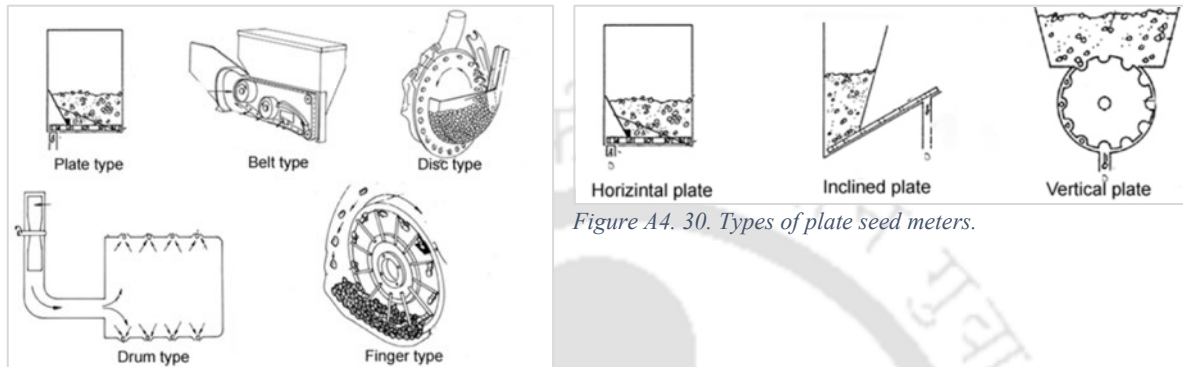

Figure A4. 29. General types of precision seed metering devices.

Figure A4. 30. Types of plate seed meters.

Mass flow seed metering (Murray et al., 2006)

Aim: To meter a consistent volume of seed per unit of time to give an average seed spacing equal to the desired spacing.

Results: We studied different meters (Figure A4. 31) and selected the fluted roller as suitable for dispensing wheat, moong, mustard, and similar small seeds. It is also a low-cost solution. It could also be combined with the precision seedbox. We designed a seed divider mechanism to dispense two lines of seeds with one meter (Table A4. 7 Idea 18). It could reduce the weight of the seeding unit.

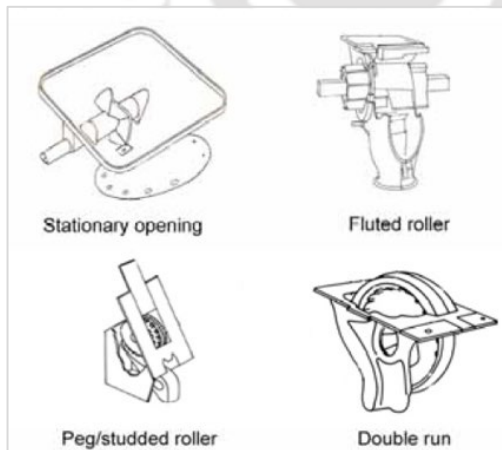

Figure A4. 31. General types of mass flow seed metering devices.

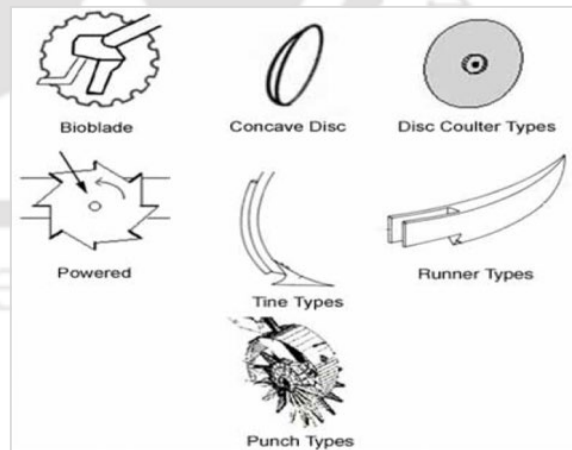

Figure A4. 32. Common types of furrow opening devices.

Seed delivery systems (Murray et al., 2006)

Aim: To optimize the delivery of seeds from the meter to the furrow opener.

Results: We studied gravity-based, mechanical, and pneumatic systems and selected a gravity-based delivery mechanism. That was deemed suitable for the purpose and was low-cost. We reduced the distance between the metering and delivery point. We optimized the delivery tube angle and height, compensating for the forward speed of the BP (Table A4.7, Idea 4). We reduced the delivery pipe diameter to avoid seed bouncing on its walls, thereby decreasing the delivery precision.

Furrow opener (Murray et al., 2006)

Aim: To open the soil for seed placement.

Results: We identified the tine type furrow opener as most suitable (Figure A4.32). We changed its rake angle to 10 degrees considering the similarities with a tractor's tine type furrow opener (Table A4.7, Idea 28).

Flails (Jat et al., 2013)

Aim: To clear up the furrow of grass/ crop residues from the fields.

Results: We designed a gamma-type flail arrangement inspired by the *happy seeder* design (Figure A4.33, Figure A4.34).



Figure A4.33. J-type and Gamma-type flail blades used in Happy Seeder. Source - (Jat et al., 2013)

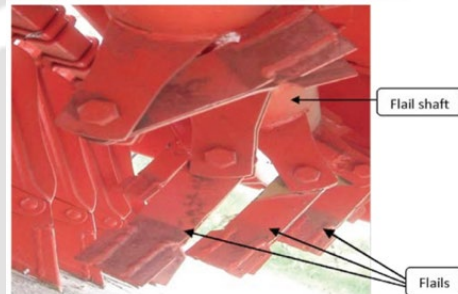

Figure A4.34. Flails and flail shaft. Source - (Jat et al., 2013)

Mechanization as a package

Aim: To design a complete mechanization package where mechanization is planned considering the entire value chain of a particular crop, from soil preparation to final processing (Hilmi, 2013; Sims et al., 2016; Sims and Kienzle, 2009).

Social trends

We identified the social issues during the FGDs and participatory design sessions and then further investigated them through literature research. The issues identified and the trends against them are as follows:

- ♦ Gender dynamics - Agricultural mechanization, without any doubt, reduce the physical drudgery of women involved in it. However, many researchers (AIDOS, 1986; Mallaiah, 2009; Poats, 1991) worldwide argue that mechanization in agriculture removes women from this occupation leading to degradation in their socio-economic position. From the stakeholder interviews, we gathered that women were expected not to leave their villages for earning money in rural Bangladesh as it is considered moral degeneration. Hence, the women left out of the agricultural economy will eventually have no work. That can degrade their socio-economic situation.

- ♦ Unpaid Labor - One of the operators interviewed said that his sister or wife works as the co-operator and fills seeds in the box. In this given scenario, although the woman shares some part of the job, she does not receive a co-worker's payment. This might imply the engagement of more women as unpaid helpers and not paid co-workers. This is a common phenomenon reported elsewhere in this sector and others. ([Das and Khan, 2016](#); [Khatun et al., 2016](#); [Komatsu et al., 2018](#); [Seymour, 2017](#)).
- ♦ Feminization of agriculture - Due to men's migration towards cities, the number of women agricultural workers is increasing. ([Kelkar, 2007](#); [Sahed et al., 2017](#)).
- ♦ Ownership as a source of pride - Ownership of AM was also a source of pride. The bigger and more powerful the machine, the greater the pride.
- ♦ Word of mouth - The power of word-of-mouth advertisement amongst close-knit rural communities was enormous. It could impact products' acceptability and perception. ([Hossain et al., 2015](#); [Hossain et al., 2017](#))
- ♦ Ownership to Rented model - A growing trend in the AM market is opting for the service model than owning the machine. This model ensures better utilization of the machine, a higher return rate on the investment, and the possibility of using better machines, which are also more expensive. ([Mottaleb et al., 2017](#))
- ♦ Training - Vocational training courses in the AM sector are offered in Bangladesh but need further development ([Elbushari and Aktaruzzaman, 2012](#)). AM related vocational training was amongst the most popular training programs in Bangladesh ([Islam, 2014](#)).

Economic Trends

We identified the economic issues during the FGDs and participatory design sessions and then further investigated them through literature research. The issues identified and the trends against them are as follows:

- ♦ Landholding size - Average size of farms is less than 2 hectares, and the average size has been reducing over the years. The challenges of the same are discussed at length in Chapter 2, section [2.1.2](#).
- ♦ Input cost - The input cost for agriculture is increasing due to the need to use a higher amount of fertilizer and pesticides each year and the greater energy required for pulling water from the ground due to reducing the water table. Chapter 2, section [2.1.2.13](#).
- ♦ Economies of scale - Economies of scale and integrated farming benefits need to be strategized for resilient small farms ([Chavas and Kim, 2007](#); [de Roest et al., 2018](#)). Appropriate mechanization to support the same is required. Also, in this context the intensity of cropping is crucial to determine the scope for mechanization.
- ♦ Subsidy and loans - The availability of government subsidies and bank loans for AM purchase is a source of positive boost for AM purchase in Bangladesh ([Mottaleb et al., 2016](#)).
- ♦ Capital intensive - AM, especially the energy-efficient options, are capital intensive and in developing countries that is a major investment for most of the farmers ([Indian Council of Food and Agriculture, 2017](#)).
- ♦ Complete mechanization packages - A value chain approach to conducting agriculture involves looking at agriculture *from producer up to sale to the consumer* ([Sims and Kienzle, 2016](#)). When all involved stakeholders in the value chain are brought in together and work in tandem with each other, it produces higher returns ([Yaregal, 2014](#)), generates and sustains rural employment, reduces post-harvest losses, enhances the quality and integrates the smallholders into the market economy ([Sims and Kienzle, 2016](#)). Several studies have reported that mechanization can positively aid in achieving this value chain approach if designed considering all phases of the value chain: production, harvest, post-harvest, processing, and retailing ([Hilmi, 2013](#); [Sims et al., 2016](#); [Sims and Kienzle, 2009](#)). Thus, complete mechanization packages are seen as a prospective AM approach for holistic development of the sector.

The results of the process (1.4) are summarized in [Table 5.2](#).

A4.1.4. Analysis of cases of excellence for sustainability (1.5)

Here the designer is supposed to identify other sustainability-oriented design solutions from the same field and use them to get inspired and, after that, the designer also compares the redesigned solution. Literature research presented in chapter 4 shows no literature with a holistic view of sustainability for AM design. As a result, we could not perform this process. [Figure A4. 35](#) diagrammatically presents the process, sub-process, the expected results, and the tools.

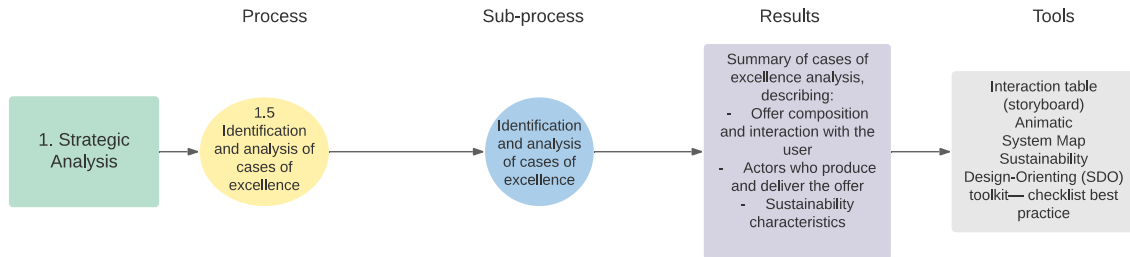

Figure A4. 35. Strategic analysis – (1.5) Analysis of cases of excellence for sustainability. Source: [\(Vezzoli et al., 2014\)](#).

A4.1.5. Analyze sustainability & determine priorities for design intervention in view of sustainability (1.6)

We involved all the stakeholders using a participatory design approach to analyze the existing scenario's sustainability and determine design intervention priorities using the “SDO toolkit - checklist existing system”. [Table A4. 4](#) presents the same. [Figure A4. 36](#) diagrammatically presents the process, sub-process, the expected results, and the tools.

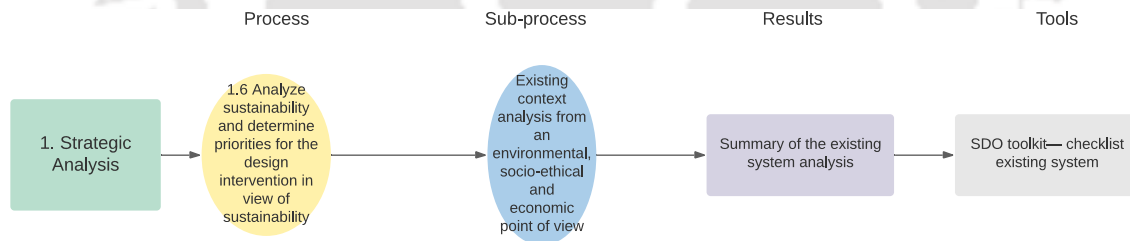

Figure A4. 36. Strategic analysis – (1.6) Analyze sustainability & determine priorities for design intervention in view of sustainability. Source: [\(Vezzoli et al., 2014\)](#).

Table A4. 4. SDO Toolkit Checklist - Existing context analysis from an environmental, socio-ethical, and economic perspective and priority setting.

Environmental Sustainability	
Criteria	1. System life optimization (Priority: High)
Sub-criteria	Is infrastructure with a short lifespan used in the system? Are disposable products, packaging, or support products used? Do parts of the system tend to be technologically obsolete? Or to be culturally/ aesthetically outdated? Is the system individually used, when it could be shared in some of its parts? Do some parts of the system (product, infrastructure, support product) tend to be worn out more quickly (than others)? Do the system lack maintenance and up-grading services? Others
Analysis	The fasteners (nuts and bolts) and the chain and sprocket mechanisms used were of low quality. The fasteners would loosen or break after a few fastening and unfastening operation. They were also damaged during use.

	Since they could not be tightened optimally, they loosen, resulting in the break down during usage. The chain elongated during usage and kept slipping, resulting in seed drop misses.
	The plastic precision seeds metering plates warped in the sun. The small seeds then got stuck in the gap created and caused its breakage.
	The rotary blades were bought from China, modified with improper heat treatment. As a result, blade life was low.
	It was not designed considering hard soils. The machine, thus, always broke under such circumstances.
	The lifespan of the 2WT for which BP was built is short, 3 - 5 years. Post that, it is not useful for agricultural work.
	The manufacturing techniques and raw materials available are technologically dated. However, the current market does not offer a possibility out of this problem.
	The farmers and LSPs aspire for a tractor for the sheer pride of owning a powerful machine. A 2WT being a much smaller machine with lower power (9 - 13 HP), did not provide them with the same degree of satisfaction.
	Also, one has to walk behind the 2WT to operate it. That created the image of a dated product for the farmers and LSPs.
	Since BP's weight distribution has not been worked out appropriately, the operator has to tie a sandbag in front of the 2WT. That further gave it the aesthetics of a "Jugaad" product, which was not seen with very high esteem or aspirational value.
	The rotary blades wear out the fastest. The 2WT also wears out quite fast (3-5 years).
	The system lacked trained repair personnel.
	Spare parts were not available in the market.
	The manufacturer had released several BP versions and did not maintain records of version, components, changes, and the purchasers, making maintenance and up-gradation tough.
	The operators were not well trained in operating BP. As a result, they set the machine incorrectly and ended up damaging or completely breaking down its parts.
	The manufacturer was not aware of the technical use of the various components as designed by BARI scientists. They removed some parts, leading to inefficient performance and breakdowns.
	The manufacturer's staff were not trained in manufacturing techniques and quality control. As a result, machine component dimensions varied, leading to ill-fits and machine breakdowns.
	Lack of knowledge of materials and manufacturing processes led to a lowering of product life.
	Lack of quality component suppliers led to a lowering of product life.
Criteria	2. Transportation/ distribution reduction (Priority: High)
Sub-criteria	Is there any excessive transportation of goods? Is there any excessive transportation of semi-finished products or by-products? Is there any excessive transportation of people? Are transportation means in service fully used? Is there any excessive use of package? Others
Analysis	The BP did not have rear wheels and weighed 140 Kg. It was transported using a tempo from one village to another. The effort required to load it up and down the tempo was very high.
	In the absence of a widespread repair and maintenance system, the purchaser would have to bring BP to the manufacturer each time for maintenance and repairs.
Criteria	3. Resource reduction (Priority: High)
Sub-criteria	Is the system consuming high quantities of energy? Is the system consuming high quantities of natural resources? Is the system absorbing high quantities of consumable? Are products, packaging, or support products highly material-intensive?
Analysis	The current BP parts were not optimized. The rotary blades and the bed shaper consumed much energy due to their configurations, and the 9 HP 2WT was insufficient.
	Soil residue blocked the furrow opener. That further adds to the drag for the 2WT, consuming more energy.
	The 140 Kg weight of BP consumed a considerable amount of energy (diesel). Due to its weight, the operator also had to spend high muscular energy to lift it at each row's end. That caused fatigue and pain for the operator. The intense labor limits per day operations that one could target.
	Walking behind the 2WT requires a large amount of human energy.

	<p>A counterweight (sandbag) was usually kept on the BP front at all times to ease its lifting, causing higher fuel consumption in carrying dead weight.</p> <p>Since it achieves four functions simultaneously, plowing, seeding, fertilizing, and bed shaping, the BP has to be operated at the slowest speed of the 2WT. Thus, the energy consumption is high.</p> <p>Diesel consumption is high.</p> <p>The blades erode relatively fast and are a consumable of concern.</p>
Criteria	4. Waste minimization/ valorization priority (Priority: Low)
Sub-criteria	Does all waste end up in the landfill? Does the system produce high quantities of landfill waste at the end of service life? Do the production, packaging, and support products produce significant quantities of landfill waste?
Analysis	<p>The worn-out rotary blades could be put into the recycling process but are not at this moment.</p> <p>Most parts were made of various mild steel grades, which can all be recycled at the end of life.</p> <p>Few plastic parts were present, and they end up in landfills.</p>
Criteria	5. Conservation/ biocompatibility (Priority: No)
Sub-criteria	Is all the energy produced from fossil fuels? Is all the energy produced from exhausting resources? Does the system use mainly depleting and/ or non-renewable materials for the production processes? Does the system use mainly depleting and/ or non-renewable materials for products, support products, packaging, and infrastructure? Others?
Analysis	<p>The 2WT for which BP was built runs on diesel.</p> <p>The manufacturing process used welding & drilling machines running on electricity from the grid.</p> <p>Most parts were made of various mild steel grades, a depleting and non-renewable resource.</p>
Criteria	6. Toxicity Reduction (Priority: Medium)
Sub-criteria	Are the processed resources toxic or potentially toxic for the workers? Are the processed resources toxic or potentially toxic during distribution? Are the processed resources toxic or potentially toxic for the user? Are the products, support products, packaging, or infrastructure toxic or potentially toxic during after service time treatments? Are there any problems with forced or child work? Other?
Analysis	<p>The workshop did not have appropriate protective gear for its staff for activities like welding. Thus, UV exposure was massive for all workers.</p> <p>The 2WT works on diesel and, while operational, release much smoke.</p> <p>JE could employ children in the manufacturing process.</p> <p>BP ergonomically cannot be operated by children as it requires much muscular power.</p> <p>BP produces soil dust while working due to the relative placement of the components.</p> <p>As soil residue frequently blocked the furrow opener, the operator removed the dust guard to have clear visual access, leading to even more dust.</p>
Socio-Ethical Sustainability	
Criteria	1. Improve employment and working conditions (Priority: High)
Sub-criteria	Are there any problems with health and safety? Are there any problems with discrimination in the workplace? Are there any problems with work overload and inadequate wages? Other?
Analysis Criteria	<p>Due to BP's weight, it was challenging to lift it at each row's end. The activity led to heavy fatigue and physical pain for operators. Some operators also reported getting fever the next day.</p> <p>BP generated dust while working.</p> <p>The 2WT generated vibrations, which is a potential health hazard.</p> <p>The 2WT ran on diesel and generated smoke during operation.</p> <p>The workshop did not have appropriate protective gear for its staff for activities like welding. Thus, UV exposure was massive for all workers.</p> <p>Due to a lack of soft soil operation training, an operator was about to topple along with the machine while turning it in the field. Under such circumstances, the rotary blade does not stop rotating, which can be dangerous.</p> <p>No discrimination was observed. However, the amount of physical strength required to operate BP creates a situation wherein women might not want to become an operator.</p> <p>Walking behind the BP is a very tiring activity and limits the operator's area per day.</p>

	<p>BP earned its operator 400 Taka (~345 INR) for bed plantation of 1 Bigha. That includes the fuel cost (running BP & transportation), the cost of an operator and a co-operator (maybe), BP's cost, depreciation and maintenance, and incidental expenses like medical facilities, interests on loan, etc. In case the operator is not the owner of BP, it will also include rent for using it or a salary to the operator and profits to the owner. Thus, although the machine works out to be a very economical solution for the farmer, one needs to calculate from the operator and the LSP's perspective. The calculation also needs to estimate how much land can be plowed safely in a day without physical severe exhortation and damage. Thus, 400 Taka is not fair compensation.</p> <p>Usually, the operator's sister or wife worked as an unpaid co-operator, helping refill the seedbox.</p>
	2. Improve equity and justice in relation to stakeholders (Priority: High)
Sub-criteria	Are the stakeholders criticizing the supply system? Is the client/ final user criticizing the supply system? Are there any unjust relations between the partnerships? Are there any unjust relations with suppliers, subcontractors, and sub-suppliers? Other?
Analysis	The farmers, LSPs, operators, and dealers complained about BP's low quality and the lack of spare parts and maintenance services.
Analysis Criteria	The manufacturer complained about a lack of quality raw materials, component suppliers, and a trained workforce.
Sub-criteria	3. Enable responsible and sustainable consumption (Priority: High)
	Is the client/ final user able to clearly and easily acknowledge the social (un)sustainability along the whole value production chain? Is the client/ final user able to understand the responsible/ sustainable behavior by the supply system? Other?
Analysis	The operators are amongst the most vulnerable of all stakeholders. They acknowledged the strenuous operation but believed that they needed to become stronger if they have to operate it. They did not demand BP, which gives them a better working condition.
Sub-criteria	All stakeholders thought that dust is a natural outcome of AM and did not see the need for improvement.
Analysis Criteria	None of the stakeholders considered more gender-inclusive BP as a redesign criterion.
Sub-criteria	The users wanted full responsibility from the supplier side. The two users who bought BP returned it once they found its shortcomings.
	4. Favor/ integrate weaker and marginalized strata (Priority: Medium)
	Does the supply system create obstacles or limit access to people with weaker social status (e.g., kids, elderly, differently able, etc.)? Is the offering system accessible to people with lower incomes? Does the offering system favor in any people's marginalization? Other?
Analysis	The offering system is accessible to people with lower incomes.
Sub-criteria	Women who are currently involved in seeding activities will lose their employment opportunities. It might lead to their marginalization if alternative employment is not generated
Criteria	5. Improve social cohesion (Priority: No)
Sub-criteria	Is the offering system creating or favoring any form of intra-gender, intra-cultural, intra-generational exclusion? Is the system creating/ favoring any forms of discrimination (sexual, religious, cultural, gender)? Other?
Analysis	The weight of BP can deter women from becoming operators.
Sub-criteria	If training opportunities for women are not created, they will be deterred from entering this arena.
Criteria	6. Empower/ valorize local resources (Priority: High)
Sub-criteria	Does the current reference system impoverish local cultural values and identities? Does the current system offer only one solution/ few variations for all regions and cultures? Does the current system hurt the social well-being of the local community? Is the current system impoverishing local economies? Is the system absorbing local non-renewable resources? Other?
Analysis	The solution is not designed for hard soils and fails terribly under such conditions.
Sub-criteria	It can generate employment as operators, maintenance service personnel, and business opportunities as LSPs.
Economic Sustainability	
Criteria	1. Market position and competitiveness (Priority: High)

<i>Sub-criteria</i>	Do you have a weak market position in the current system? Are there possibilities to improve your market position that you do not use at the moment? Do you see current and future threats for your market position? Others?
<i>Analysis</i>	The consortium had successfully launched several products in the same market in the past. They are well-known for their work. IDE-B and CIMMYT can enter into training manufacturers and operators. Both teams already engage in training to a certain extent. CIMMYT has published the book "Made in Bangladesh: Scale-appropriate machinery for agricultural resource conservation," which targets training small-scale local manufacturers in AM manufacturing (Krupnik et al., 2013). iDE-B and CIMMYT are funded for their activities by funding agencies like USAID and Gates Foundation. Once a target market for intervention is successfully achieved, they exit that market and initiate work in another target area. The country does have many other NGOs and research organizations that are working following a similar model. We did not research threats to this model of operation.
<i>Criteria</i>	2. Profitability/ added value for companies (Priority: Medium)
<i>Sub-criteria</i>	Is the profitability of the current system low for your company and other external partners? Is there anybody producing better offers than you more cheaply? Are there missed opportunities to create more value in the whole value chain/ system? Is somebody else using this opportunity (e.g., selling your products second hand)? Other?
<i>Analysis</i>	Not a profit-based organization. The manufacturing partner can profit with the BP as no similar machine exists in the market. Due to BP's failure and the spread of word of mouth on its low quality, the dealer's image and credibility had suffered. They are the first to try to make a BP commercially. Training of operators and manufacturers is an opportunity that is still not well-targeted.
<i>Criteria</i>	3. Added value for customers (Priority: High)
<i>Sub-criteria</i>	Is the profitability/ value low for customers/ consumers? Do you fail to offer concrete, tangible savings in time, material use, etc. for the customer? Do you fail to offer 'priceless,' intangible added value like esteem, experiences, etc. for which the customer is willing to pay? Are competitors creating more value for money for the customers? Other?
<i>Analysis</i>	The customers aspire for a tractor and see the 2WT-based BP as an inferior product. The machine breaks down so frequently and does not work as intended that customers see it as a waste of time, money, and effort. Tractors are perceived as more valuable.
<i>Criteria</i>	4. Long term business development/ risk (Priority: Low)
<i>Sub-criteria</i>	Are there any threats in the current system for your business in the longer term? Do you foresee that the customer's needs for your offer will disappear? Are there any major risks from external sources for your offer? Is your offer more a short term business? Will it disappear soon? Is your offer threatened by technological or fashion changes? Is your financial background sound? Other?
<i>Analysis</i>	If the 2WT goes out of the market, so will the BP attachment. If the manufacturer, Sifang, changes its 2WT model, the existing BP design will need modifications. Changes done by Sifang are not under the control of the system stakeholders. If farmers decide to cultivate as a group by combining their farms, they can use tractors. If the users switch to another make of 2WT, the current attachment will need a redesign. Agronomists argue for switching to conservation agriculture practices. If the same happens, bed planting as an agronomic practice can become less popular.
<i>Criteria</i>	5. Partnership/cooperation (Priority: High)
<i>Sub-criteria</i>	Is your market position in danger? Do you have a weak market position that you want to improve? Can you use a strategic partnership and cooperation? Are your competitors co-operating and therefore have a better market position? Are you missing competencies internally that you need today and in the future? Other?

<i>Analysis</i>	Needs to build strategic partnerships with component manufacturers, raw material suppliers, and repair and maintenance service providers.
	An internal design team, involved from the beginning of any new project, can prevent similar problems in future projects.
	In this project, the reverse-engineered version of the BP was not tested extensively. Instead, the prototype was put into production and then into the market for sale. Internal processes need to be built so that the partnership's engineering team can take care of such scenarios in the future.
<i>Criteria</i>	6. Macro-economic effect (Priority: No)
<i>Sub-criteria</i>	Are there problems on a macroeconomic level, e.g., disclosure of participants in the economy, monopolistic structures, rebound effects? Other?
<i>Analysis</i>	Nil

[Table 5.2](#) summarizes the results of the process (1.6), the gaps, and proposed addition.

A4.1.6. Strategic Analysis - Sustainability and Agriculture

The ICS toolkit aided in the environmental sustainability assessment and priority setting for SAM's product part following a life cycle design approach. On the other hand, the SDO toolkit supported sustainability assessment and priority setting for design intervention on all three dimensions for the entire PSS. However, as both tools are not explicitly designed for agriculture, they cannot check the sustainability impact of SAM from an agronomic perspective. Thus, we designed the SAC checklist that can be used by a SAM designer to assess sustainability and set sustainability-oriented design priorities in the agricultural context. Section [5.2.2.2](#) presents the SAC checklist development process and the checklist. [Table A4. 5](#) below presents the case assessment using the SAC checklist.

Table A4. 5. Case assessment using the SAC checklist.

Sustainable Agricultural Criteria Checklist	
<i>Criteria</i>	1. Short-term & immediate effect on (Priority: Medium)
<i>Sub-criteria</i>	soil health; air health; water health; the crop/ plant/ tree/ produce; other life forms like earthworms, bees, insects, birds, rodents, etc.; other
<i>Analysis</i>	Bed planting causes massive soil disturbance leading to soil erosion.
	BP created soil dust.
	The 2WT runs on a diesel engine and pollutes the air.
	The furrows can be used for irrigation, thus saving on irrigation water. For water-loving crops, the furrows can provide a favorable growth environment with a lesser amount of water.
	It is helpful for crops that require finely prepared soil bed for optimal growth.
	Bed planting helps to protect crops from floods.
	Better sunlight access and nutrient access is possible.
	Farmers report higher productivity with bed planting techniques.
	BP did not produce adequate soil compaction leading to unfavorable growth conditions for the seeds. If the soil around a seed is not well compacted, birds and ants tend to feed on them.
	Due to a lot of soil disturbance, the earthworm's habitat is disturbed.
	Due to better spacing between crops, rodent attacks on crops are less.
	Since fertilizer can be applied beside the seed, the quantity of fertilizer required reduces, and better utilization of the nutrients is possible.
<i>Criteria</i>	2. Long term effect on (Priority: No)
<i>Sub-criteria</i>	soil health; air health; water health; the crop/ plant/ tree/ produce; other life forms like earthworms, bees, insects, birds, rodents, etc.; other
<i>Analysis</i>	The long-term impact of the massive turning of soil might change the soil structure.
	Permanent bed making and future reshaping with other conservation agricultural practices can aid in soil friendly agriculture.

	Diesel engines cause pollution.
Criteria	3. Bearing of the AM on the agro-system activities (Priority: Medium)
Sub-criteria	soil preparation; planting or seeding; fertilizing or nutrient adding; weeding/ adding pesticides/ insecticides; plant care activities; harvesting; post-harvesting; other
Analysis	It can reduce the time and cost. Better seed spacing can ensure better nutrient availability. Fertilizer application beside the seed ensures better nutrient utilization. Attachments for mechanized weeding of the furrows can be developed. Bed planting provides better access to crops for plant care activities. Attachments for plant care activities and harvesting can be developed once the crops are planted at regular intervals.
Criteria	4. Impact on sustainable farming practices (Priority: No)
Sub-criteria	conservation farming; organic fertilizing; organic farming; intercropping; other
Analysis	BP does not support conservation farming, but if permanent beds can be made, it can be attempted to use conservation farming next. It needs further exploration. It can be designed to support organic fertilizing, organic farming, and intercropping.
Criteria	5. Auto-optimization of functioning based on (Priority: No)
Sub-criteria	soil moisture; soil nutrients; soil structure; crop type; other
Analysis	It can be designed to support the auto-optimization of functions based on crop type, soil moisture, nutrients, and structure.
Criteria	6. Machine Typology Efficiency concerning the (Priority: High)
Sub-criteria	human energy required; machine energy required; purpose; other
Analysis	The 2WT is tiring to operate due to the need for walking behind it and heavy weightlifting. The BP attachment makes it heavier to lift if weight balancing is not achieved through design. The current 9 HP machine cannot achieve the aimed operations. Mechanical redesign and calculation need to be done to check feasibility. Also, a comparison of energy consumption versus the quality of work delivered can be made between 2WT, manual, draught- and tractor-powered bed planting for the target small farms. Since the market has many 2WT, and most farms are small farms where tractor operations are not optimal, the machine typology is appropriate. If the machine can be made less tiring to operate, the PSS model of operating BP becomes acceptable to operators.
Criteria	7. Impact on __ due to the AM induced pre-processing needs (Priority: High)
Sub-criteria	labor/ machine preparatory operation/ process/ product/ service/ system requirement/ others
Analysis	The 2WT comes with a puddling attachment. This attachment needs to be replaced with the BP attachment. This process involves lifting heavyweights. It also needs 3-4 people to achieve the same. The current BP needs the field to be already plowed a couple of times. If the soil moisture content is appropriate, and the gap between plowing and bed planting is small, bed planting works. Else either the machine breaks down too often, or beds and soil compaction is inadequate.
Criteria	8. Impact on __ due to the AM induced post-processing needs (Priority: Medium)
Sub-criteria	labor/ machine preparatory operation/ process/ product/ service/ system requirement/ others
Analysis	Transporting the machine from one field to another is very noisy and damages the bed shaper. Transporting it from one village to another, thus requires a tempo. Lifting the BP on the tempo is a heavy task and requires 4-5 people.
Criteria	9. Influence of the workforce on the AM
Sub-criteria	design and development team; manufacturer's expertise, infrastructure, spending power, etc.; the literacy level of the labor force on the decision to use/ purchase, usage, repair, maintenance, and disposal; training level of users; users' perception and experience on the decision to use/ purchase, usage, repair, maintenance, and disposal; gender and age on the decision to use/ purchase, usage, repair, maintenance, disposal

<i>Analysis</i>	BARI's current BP is a good machine when considered from an agronomic requirement fulfillment point of view. It achieves soil pulverization, seeding, and bed making. It also allows tons of setting possibilities, which are essential for agricultural scientists. They can set BP at multiple parameters and test its performance. However, it becomes confusing and difficult for an illiterate or semi-literate operator. They need straight – forward instructions and simple interfaces.
	The other issues were the inadequate level of engineering refinement of the S-BP, inadequate training of operators, lack of ergonomic considerations, and introduction of the machine as a product when it still has a test rig look.
	The manufacturer lacks formal training in materials and manufacturing, and so does his workshop workers. Hence parts are ill-engineered, and the idea of quality control is missing. Also, a brief scan of other prospective manufacturers of the region reveals either a lack of facilities for proper manufacturing or a setup too big for agreeing to the volumes required.
	Lower literacy level demands a simpler interface than the current one.
	The operators are not well trained, and the machine kept on breaking down because of the wrong settings at which it was put on. The operators also lack agronomic knowledge, leading to non-optimal field condition identification and bed planting application.
	Due to word of mouth spread of information regarding the machine's lower build quality, people were reluctant to purchase.
	Due to many free demonstrations, the users believed in the status quo and postponed the purchase decision.
	The users perceived the machine as a test rig because of its visual effects and hence a lack of trust and ownership desire.
	The users aspire for a tractor as it gives them a feeling of power and money. The 2WT fails to attract that aspirational value.
	The 2WT is useless for agricultural usage post 3-5 years.
	Rumors on upcoming government subsidy also led to postponing purchase decisions.
	The machine is very heavy and tiring to use even for men. Thus, women operators are dissuaded. Also, no training efforts have been put in this direction.
	Due to political unrest in a nearby village, all men were arrested by police during the sowing season. The women could manage sowing activities due to the machine.
	The machine operation is challenging for older people. However, it can help older farms to continue with their farming activities despite the labor shortage.
	<i>Criteria</i>
<i>Sub-criteria</i>	literacy level; training level; perception; experience; gender/ age/ status; others
<i>Analysis</i>	The machine is expected to become a source of employment in rural areas. The training program can be kept open for people with even an elementary education level. One of the best operators we met was illiterate.
	The workforce's perception and experience with current BP are negative, but bed planting as an agronomic practice is very positive.
	It can be designed to be sensitive to aspects like local gender dynamics, age, and status.
<i>Criteria</i>	11. Health & Safety (Priority: High)
<i>Sub-criteria</i>	Health/ accident dangers during usage/ storage/ transport of the AM? When operating the AM, is it possible to use protective gear? Others?
<i>Analysis</i>	It requires an awkward position taking while assembling, repairing, and operating it. It also causes heavy fatigue and muscle pain to operators. It generates a lot of soil dust and diesel smoke.
	The current BP has lots of sharp corners. Turning the machine at the edge of the field can also cause accidents if the operator is inexperienced.
	BP generates massive amounts of smoke and soil dust.
<i>Criteria</i>	12. Finance (Priority: Medium)
<i>Sub-criteria</i>	Will the consumer need financial support for buying the AM? Will that financial assistance be accessible and affordable? Is the financial debt repayable by using the AM with the revenue generated? Is subsidy or assistance from the government or in some other form available? Is help available to the customer for the

	selection of the ideal AM package? Are economic aid available for the AM's operation and repair costs? Does the landholding size influence the AM operation and lucrativeness?
Analysis	Since BP is being targeted for service, it is expected to recover the costs within a season's operation. However, the market is expecting government subsidy, as is the norm for such kind of products.
	Loans are available and repayable with the income generated.
	For government subsidy and assistance, the partnership needs to engage with appropriate stakeholders.
	Only one BP package is available. This does not cater to different scenarios.
	No economic assistance is available for BP's operation and repair costs.
	2WT is advised for small to medium farms as cost-effective.
Criteria	13. End-of-life (Priority: No)
Sub-criteria	Will the AM have significance for other uses post its primary use-life? Does a particular disposal approach (like scrap value) help the user?
Analysis	BP does not have an after-life use. It has scrap value at end-of-life.
Criteria	14. Impediments due to infrastructure (Priority: High)
Sub-criteria	Are there barriers due to physical infrastructure? Are stakeholders aware of the barriers? Are there other infrastructure barriers?
Analysis	No repair and maintenance infrastructure exist, leaving the buyer at the mercy of his/ her inventiveness to deal with break downs.
	Operators and manufacturers require training.
	Appropriate manufacturing industry infrastructure is missing to a great extent.
	The spare parts supply chain is missing.
	JE is minimally equipped for manufacturing. Most operations are manual.
Criteria	15. Reduction in (Priority: Low)
Sub-criteria	seed wastage, fertilizer use, pesticide use, and its damaging impact on the people and planet; wastes and emissions; time for completion of activities; farm labor use and drudgery of farm laborers; child labor; cost?
Analysis	Seed wastage can be reduced as seeds can be applied at regular intervals rather than broadcasting.
	Fertilizer wastage can be reduced by applying it at the proximity of the seed than broadcasting.
	There will be a reduction in time and the guarantee of timely completion of activities.
	There will be a reduction in farm labor use and the drudgery of farm laborers.
	In the BP operation, child labor can't be used due to the amount of physical labor and height requirements. In the manufacturer's place, no such assurance can be obtained.
	Soil preparation and sowing cost is expected to decrease.

A4.2. Exploring opportunities (2)

Here the goal is to generate ideas for sustainable services and systems, cluster them, and expand them. The two processes to achieve the same are (2.1) *generating sustainability-oriented ideas* and (2.2) *outline a design-oriented sustainability scenario* (Figure A4. 37). The following subsections elaborate on the work done under each of these processes.

A4.2.1. Generating sustainability-oriented ideas (2.1)

From the analysis conducted, the project's satisfaction unit was defined as effective bed planting, where effective is defined as timely, cost-efficient, and high-quality performance for the farmers, LSPs, and operators. Table A4. 6 presents the ideas generated by all stakeholders using the *SDO toolkit - orient the concept* on all three dimensions of sustainability. The toolkit aids in system and service level idea generation as illustrated in Figure 5.12. However, the SDO toolkit provided no focused guidelines for product design and DfS for the agricultural context. The results of the process (2.1), the gaps, and proposed addition are summarized in Table 5.5.

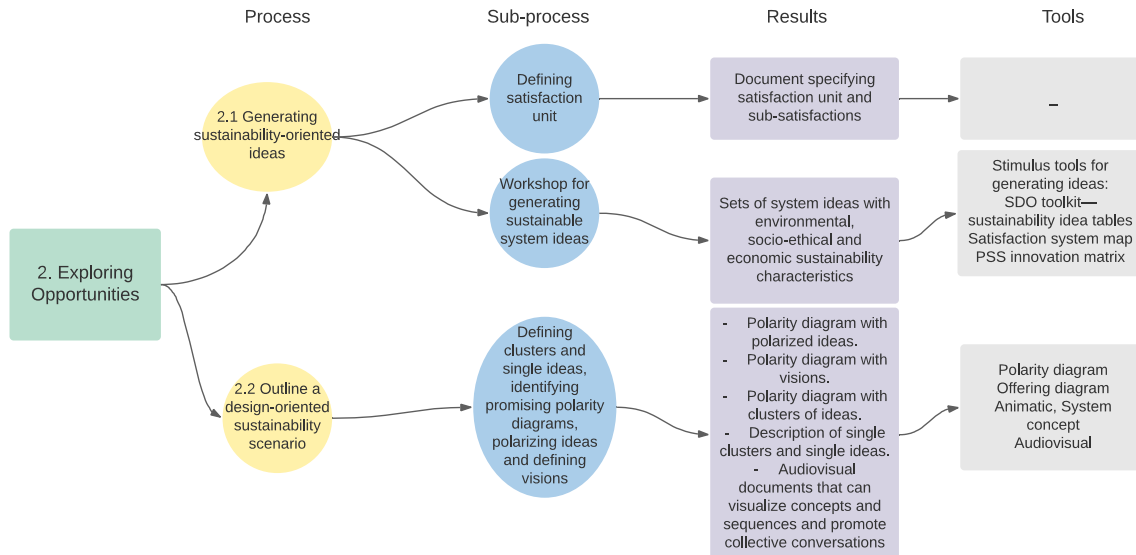

Figure A4. 37. Exploring opportunities – (2.1) Generating sustainability-oriented ideas, (2.2) Outline a design-oriented sustainability scenario. Source: (Vezzoli et al., 2014).

Table A4. 6. Ideas generated by all stakeholders using the SDO toolkit - orient the concept on all three dimensions of sustainability.

Environmental Sustainability
1. System life optimization (Priority: High)
Procure quality fasteners, chains, and sprockets from Indian manufacturers.
Use of manufacturers with quality manufacturing setup for plastic seed meters and rotary blade.
Create different designs of rotary blades for different soil types by identifying the soil types in the region.
Till the spare parts market is robustly built, provide the most frequently broken/ damaged parts as spares with BP. Identify each BP with a serial number for tracking it. Imprint the contact number of the manufacturer on it to enable buyers in case of any problems. The contact number can guide the user to replace the damaged part/provide appropriate spare parts/ other guidance according to BP's serial number.
Provide a visual operational manual which can be understood even by illiterates. The contact number can then ask the user to use it and guide through the process.
Organize training programs for operators where they are taught to operate the machine and also repair and maintain it.
Conduct training programs for creating a repair and maintenance service industry.
Design a modular BP, and one can purchase upgradations depending on their requirement with dealers' advice.
Appropriate guidebooks can be created for the same.
Design a training module for manufacturers and their staff to train them in manufacturing techniques and quality control.
That will ensure better quality products in the future.
Copyleft design and manufacturer training across the region so that more manufacturers can learn the machine's basics and adapt it to the peculiarities (like make of the 2WT/ kinds of crops cultivated) of their region.
Design BP for robust, easy transportation, less tiring operation, and market it for a service model of operation, i.e., a local service provider buys it and offers services to farmers of the region.
Create an LSP base.
Create an operator service base.
Create spare parts, repair, and maintenance base.
Create a manufacturing base comprising of local manufacturers for sheet metal and low precision requirement jobs and precision - bulk manufacturers base for precision parts supply.
Create a supply network for spare parts.
Create a training base.
Create a tractor look-alike product to upgrade its aspirational value.

Copyleft design and manufacturer training across the region so that more manufacturers can learn the machine's basics and adapt it to the peculiarities (like make of the 2WT/ kinds of crops cultivated) for their region. These modifications can then be shared amongst all manufacturers since they will be available in the free market for sale.
Training of operators for operation as well as repair and maintenance.
Training of maintenance personnel for repair and maintenance.
2. Transportation/ distribution reduction (Priority: High)
Design a BP which is easy to transport between fields and villages by attaching a rear wheel.
Design a BP with a seat arrangement that can be used while transporting it and while bed planting if the operators want to sit and bed plant.
In small fields, sitting and bed planting might not be very convenient. Hence, the seat can be made removable in case of bed planting a small field.
The rear wheel can be used for steering while moving the BP.

The weight of the rear wheel plus BP attachment should be capable of balancing the BP while transporting.

The weight of the seating arrangement should be as low as possible. An FRP seat can be used considering the low volume of productions.
A partnership between dealers who can share information regarding new support products developed by local manufacturers can be formed. Other manufacturers can then adapt these support products.
Regular field visits by CIMMYT and iDE-B field staff to collect performance data amongst users.
Local manufacturers can be trained in manufacturing the product using locally available scrap. The design of BP to be made considering local manufacturing capabilities. Some parts, like the rotary blade, which requires better-controlled manufacturing processes, can be imported or produced centrally at a more sophisticated setup (e.g., Bangladesh Machine Tools Factory).
Design BP using scrap sheet metal and mostly standard off the shelf components.
The serial number on BP for tracking and contact number for users to contact the manufacturer for information/ data.
3. Resource reduction (Priority: High)
A recycling system for the spent rotary blades can be created.
Design a platform using which farmers in the vicinity can plan their bed planting activity so that the BP provider can provide optimal services and reduce transportation costs.
Payment of the bed planting service in units: for only bed planting, for bed planting plus seed application, for bed planting with seed and fertilizer application, based on the number of the pass of plowing required, if any, before bed planting.
BP is an attachment taken to farmers with 2WT who can use the machine and make lower payments.
The blades, seed meters, and casting parts manufactured centrally by quality manufacturing setups.
Training/ marketing the fact that seeding and fertilizer application using the BP will save on the amount of seed and fertilizer requirement.
4. Waste minimization/ valorization priority (Priority: Low)
Train the operator in understanding the soil. If the soil is hard or dry, the operator should not perform bed planting directly. This will prevent BP part damages.
Create a system for taking back the worn-out blades and recycling the same.

5. Toxicity Reduction (Priority: Medium)
Protective gear for the manufacturer's staff and training on the potential risks and prevention techniques.
Design of mudguards and BP's overall configuration so that a lesser amount of soil dust is produced.
Training the operator to understand the soil conditions that are inappropriate for bed planting.
Social Sustainability
1. Improve employment and working conditions (Priority: High)
Provide a seating alternative for operating BP to optimize human energy required.
Provide seed and fertilizer storage to reduce the constant filling and the need for a co-operator.
Design the parts of BP with no or a minimum number of sharp edges to prevent accidents.
The weight balance of the BP so that it is easy to lift.
Training the operator to understand the best way to operate BP.
Training the operator in agronomic aspects so that he/ she is seen as a bed planting expert.
Protective gear for the manufacturer's staff and training on the potential risks and prevention techniques.
Design of mudguards and BP's overall configuration so that a lesser amount of soil dust is produced.
Work out a fair compensation package considering the cost of purchasing the BP, maintaining and operating, and the feasibility of the number of hours of work with it because it is strenuous to use.
If a co-worker is to be involved, ensure fair payment by considering appropriate payment package design.
Agreement with manufacturers, who engage in the manufacturing of BP, to not employ child labor.
Training of manufacturer staff in manufacturing and quality control.
A certification is attached to every training program.
2. Improve equity and justice in relation to stakeholder (Priority: High)
Create a robust supply system consisting of the BP, spare parts, training - operation & maintenance.
The compensation package should be worked out considering the strenuous nature of the work.
The operation time for operators should not be the typical 8-hour shifts, but much lower.
Two or more operators can be employed per BP, and they can take turns in operating it on different days.
Design BP for the manufacturing staff's safety.
3. Enable a responsible and sustainable consumption (Priority: High)
A warranty system that holds the manufacturer responsible for the problems in the machine.
A contact number of the manufacturer on the BP for resolving queries.
Government subsidy for greater confidence in buying.
Get endorsement/ certification from BARI, which shows that BP has been tested and cleared for sale.
Create a copyleft design and have a platform for training prospective manufacturers.
Train manufacturers to adapt BP to suit local needs and share the design with other manufacturers.
4. Favor/ integrate weaker and marginalized strata (Priority: Medium)
Sell the BP as modules to make it accessible to a broader group with varying purchasing power.
Organize training programs for women operators.
Training for manufacturers or want-to-be manufacturers to develop the manufacturing strength of the region.
5. Empower/ valorize local resources (Priority: High)
Train local unemployed youth as an operator, maintenance personnel, or manufacturer.
The utility of 2WT will improve and generate additional income for owners.
Economic Sustainability
1. Market position & competitiveness (Priority: High)
Utilize iDE-B and CIMMYT's network to create a robust training, manufacturing, and distribution channel.
Develop a series of other related attachments to gain a competitive advantage.
Project focus as "woman employment generation and social upliftment" to the donor agencies.
Project focus as "improve the manufacturing capability of the region" to the donor agencies.
2. Profitability/ added value for companies (Priority: Medium)
Training can be the new added focal point of the PSS.
Create operators club/ LSP club to organize the service delivery.
Create a channel for repair, maintenance, spare parts, and collection of damaged/ broken parts for recycling.
Improve the manufacturing capability of the region.

Outsource rotary blades and plastic parts making to appropriate players.
3. Added value for customers (Priority: High)
Advertise the timely field preparation.
Advertise the lower amount of seed and fertilizer usage.
Advertise the lower operational cost as compared to manual field preparation.
Advertise the possibility of mechanized harvesting.
Advertise the possibility of mechanized weeding.
Advertise the possibility of intercropping.
Advertise the possibility of alternate employment opportunities for rural youth.
Advertise the pride of powerful AM ownership
4. Long term business development/ risk (Priority: Low)
Secure government subsidy proactively.
Secure certification from government organizations like BARI.
5. Partnership/ cooperation (Priority: High)
Establish a strategic partnership with different types of manufacturers - small scale, large scale.
Establish a strategic partnership with BARI and the government.
Strategic partnership with dealers
6. Macro-economic effect (Priority: No)
Seek government subsidy.
Stay on the lookout for possibilities of expansion into the mechanization package offering. These will be developed in response to the possibilities of mechanized weeding, harvestings, and other plant care activities made feasible due to mechanized bed planting.

A4.2.2. Generating sustainability-oriented ideas using the ICS and SAC ideas board

(Proposed addition to fill the gap - Product design focus, sustainability in the agricultural context)

To fill in the product design focused idea generation gap, the *ICS toolkit ideas board* was used during participatory design sessions. [Table A4. 7](#) below summarizes the ideas generated. To fill the sustainability in the agricultural context gap, the SAC ideas board was used during participatory design sessions. [Table A4. 8](#) summarizes the ideas generated. [Table A4. 9](#) presents the other ideas generated from the engineering, ergonomics and human-centered requirements identified during research and not mentioned in [Table A4. 6](#), [Table A4. 7](#), and [Table A4. 8](#).

Table A4. 7. Idea generation using ICS toolkit ideas board.

Criteria	1. Use extension/ intensification (Priority: High)
Sub-criteria	<i>Design for reliability</i>
Ideas	1. Finger arrangements to ensure seeds are pushed out at the delivery point.
	

2. Even a novice operator can make straight beds using this BP. This feature is possible as now the operator can sit on the BP and operate it. Thus s/he can see where the wheel is going and better control the BP.



3. The operator keeps on forgetting to switch off the seed ON/OFF lever while taking a turn. At times when he has switched it off, he fails to turn it on. The first condition is not critical, but the second situation should not occur for the product's success. Hence, the switch is removed so that the task is easier and less error-prone.

4. The maize delivery pipe has a rear-ward inclination to cancel the falling maize seed's forward velocity component. This prevents seed from toppling forward when it hits the soil. Thus, seed to seed gap accuracy improves.



5. Markings on seed and fertilizer rate adjusters to show which rate to set the bar at depending on the seed or fertilizer type.

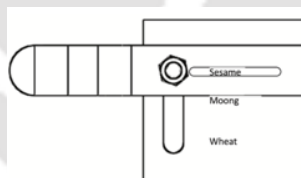

Seed rate adjuster

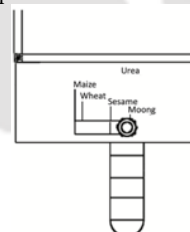

Fertilizer rate adjuster

6. Eliminate chances of error - only one setting for transporting BP and one for bed planting.



Transport mode



Bed Planting mode

7. Graphics to serve as a quick ready reference for operating BP are placed on it.

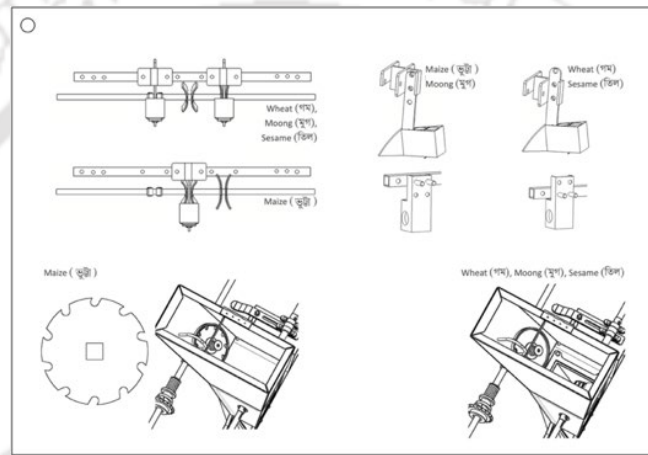

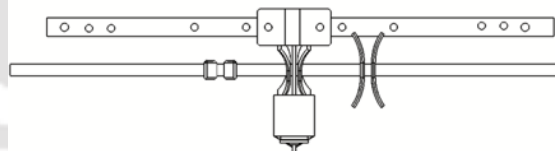

8. The furrow opener attachment - One set of holes is for a single line of seeds on the bed's center. Two sets of holes are provided to set two furrow openers at 20 cm apart.



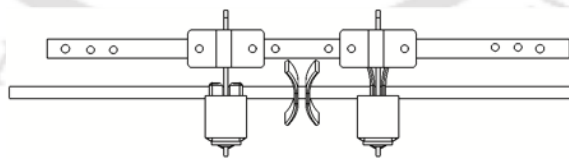

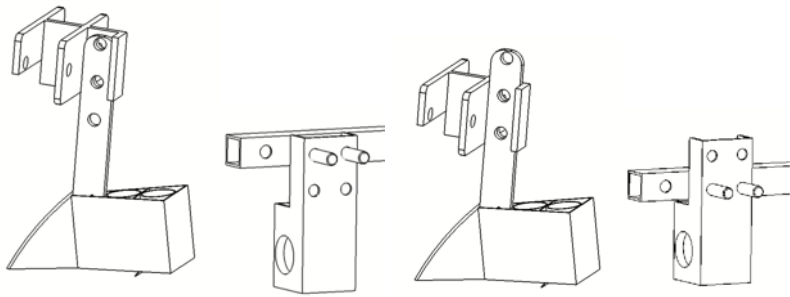

For single-line seeds like maize and sunflower.

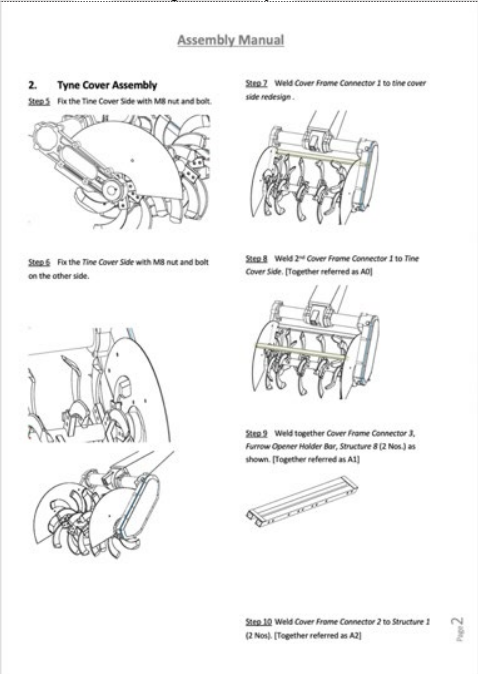

For two lines of seeds like wheat, sesame, etc.

	<p>9. Seed depth adjustment has been simplified with two slots; one for 3 cm depth plantation and another for 6 cm depth plantation. The flail arrangement height adjustment has a similar arrangement.</p>  <p style="text-align: center;">For Maize & Moong For Wheat sesame</p>
<p>Sub-Criteria</p>	<p style="text-align: center;"><i>Facilitate up-grading and adaptation</i></p>
<p>Ideas</p>	<p>10. BP will be marketed as a basic product plus additions - fertilizer metering and dispensing unit, seat plus rear wheel, storage box plus structure.</p> 
<p>Sub-Criteria</p>	<p style="text-align: center;"><i>Facilitate maintenance</i></p>
<p>Ideas</p>	<p>11. Graphical manual to serve as a quick ready reference for assembling/ maintenance of BP.</p> 

	<p>12. Information regarding serial number, manufacturer, branding, marketing, etc. for ease of tracking.</p>  <p>13. M10 bolts for all parts which require frequent opening, M5 for the ones which hardly need opening, and M3 for the ones where space constraints are high (otherwise, avoid them altogether).</p> <p>14. The nuts and bolts in high-frequency fastening-unfastening joints are easily accessible for opening and closing</p> <p>15. As far as possible, standard and off-the-shelf components for the BP.</p>
<p>Sub-criteria</p>	<p><i>Intensify use</i></p>
<p>Ideas</p>	<p>16. The BP can be operated while sitting on the BP seat or by walking. It will be more comfortable to sit and operate BP for long fields. For shorter length fields, the operator can walk with the BP.</p>  <p>Bed planting while seated by removing the rear wheel. Bed planting while walking behind the BP.</p> <p>17. Rear wheels to aid in transportation.</p> 
<p>Criteria</p>	<p>2. Material consumption reduction (Priority: High)</p>
<p>Sub-criteria</p>	<p><i>Minimize the material content of the product</i></p>
<p>Ideas</p>	<p>18. A delivery divider is designed so that one meter can dispense fertilizers for two lines of seeds simultaneously. This is also useful for dispensing fertilizers for seeds like wheat, moong, and sesame. The same delivery divider is being used to attain two lines of wheat, moong, or sesame as well by using one metering unit</p> 

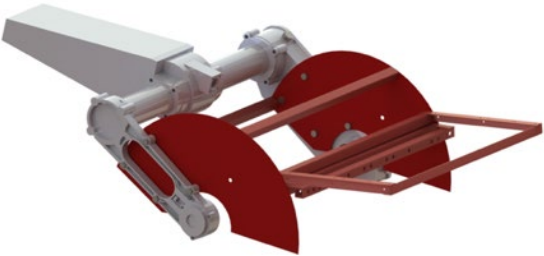
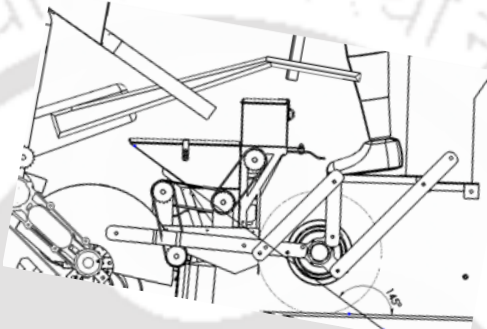
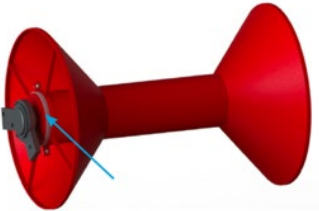
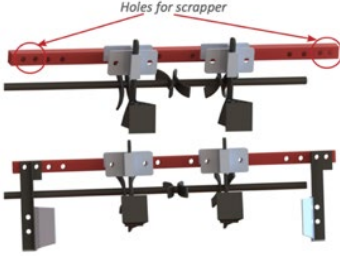
	<p>19. A chassis-based design reduces the weight of non-structural components, improves mechanical strength, and eases the assembly process—use of thinner gauge mild steel for the non-structural components.</p> 
	<p>20. The inclination of the seedbox has been fixed at 145 degrees for dispensing maize. For continuous seeds like wheat and moong, the fluted meter will be used. No inclination change will be required. The same seedbox can thus be, used for both precision and mass flow seeding.</p> 
Sub-criteria	<p>21. Use nerves structures for reducing the casting bulk. <i>Minimize material consumption during product use</i></p>
Ideas	<p>22. The possibility to set the bed shaper cone or the scrapper outside the cutting width of the rotary blades has been eliminated through design. Thus, energy waste and material damage due to frictional losses is reduced.</p>
	 <p>Welded rings prevent the cones from being shifted outside the cutting width of the rotary blades.</p>  <p>Fixed mounting positions for the scrapper eliminates the chance to set it outside the rotary blades' cutting width.</p>
	<p>23. Proper heat treatment of rotary blades to reduce their wear and tear.</p>
	<p>24. Time to time sharpening of the blades to reduce their wear and tear.</p>
	<p>25. Seed meter to be made of aluminum to eliminate plastic meters, which tend to warp and get damaged easily.</p>
Criteria	<p><i>Energy consumption reduction (Priority: High)</i></p>
Sub-criteria	<p><i>Minimize energy consumption during product use</i></p>
Ideas	<p>26. The storage box will be empty while transporting it from village to village. Thus, fuel consumption will be less in transportation. The storage box for fertilizer and seed shifts the weight towards the front during operation, leading to less effort in lifting it. This is better than tying the sandbag, which is a constant dead weight to be carried.</p>



	<p>27. A 90 degrees arrangement rotary blade shaft with alternating large and small blades. Due to better pulverization, energy wastes are minimized.</p> 
	<p>28. Furrow opener with a changed rake angle helps to improve furrow opening efficiency and to reduce energy wastes.</p> 
	<p>29. The possibility of pulverizing the soil, sow seeds, applying fertilizers, and forming beds in one go saves energy for performing each of the tasks separately.</p>
<p>Sub-criteria</p>	<p><i>Minimize energy consumption in transportation</i></p>
<p>Ideas</p>	<p>30. The storage box will be empty while transporting it from village to village. Thus, fuel consumption will be less in transportation. The storage box for fertilizer and seed shifts the weight towards the front during operation, leading to less effort in lifting it. This is better than tying the sandbag, which is a constant dead weight to be carried.</p> <p><i>Storage box for fertilizer and seed</i></p> 

Table A4. 8. Ideas generated using the SAC ideas board.

<p>Sustainable Agriculture Criteria</p>
<p><i>1. Short term & immediate effect (Priority: Medium)</i></p>
<p>A BP configuration which drops soil particles generated back to the ground.</p>
<p>Mudguard design to avoid soil dust generation.</p>
<p>Ensuring the furrow openers are not blocked by introducing a flail. This way, the operator will not tend to remove the mudguard for constant visual monitoring.</p>

Achieving a bed height of 15 cm (the highest possible with a 2WT) by improving the soil pulverization and the bed shaper design. Thus, the beds will retain its height for more extended duration post irrigation and floods, giving the crops a better chance of survival and growth.
Adequate soil compaction can be produced by <ul style="list-style-type: none"> • soil pulverization • soil accumulation by using a bed shaper, and • applying weight on top of the bed shaping roller by sitting over it while bed planting.
Fertilizer application beside the seed. The angle of dispensing of seed and fertilizer to be adjusted for the same. Also, keeping into account the forward speed of the BP.
2. Bearing of the AM on the agro-system activities (Priority: Medium)
Precision seeding mechanism to be redesigned to reduce the seed misses or double seed falling.
Delivery tubes to be made of corrugated pipes to reduce the bends in the delivery pipe, which increases the seed to seed gap in an unpredictable manner.
Lower cost of operation by optimizing the rotary blades to finish all operations in one pass. A 90° apart spiral arrangement for rotary blades to achieve the same.
3. Machine typology efficiency (Priority: High)
Seating arrangement for the operator and the option to operate the BP either by sitting or walking with it.
Optimize the rotary blades, bed shaper arrangement, and all components' weight to run the BP with a seated operator on a 9HP 2WT.
Weight optimization.
Moving weights towards the front.
Weight balancing for lifting the BP.
4. Impact due to the AM induced pre-processing needs (Priority: High)
Ease of mounting and removing the BP attachment on the 2WT.
Ease of mounting and removing the rear wheel.
Ease of mounting and removing the seat plus rear-wheel together.
Training the operator to know the right soil conditions for bed planting and the number of passes before bed planting.
5. Impact due to the AM induced post-processing needs (Priority: Medium)
Rear wheel with seat for transporting the 2WT with the BP attachment.
Design of attachments for weeding furrows, intercropping, fertilizer application, harvesting, and other plant care activities.
6. Influence of the workforce on the AM (Priority: High)
Simplifying the adjustments for seed and fertilizer selection.
Removing the possibility of setting the furrow opener to any depth and incorporating only two fixed setting possibilities, designed based on the most frequently used depths.
Removing the possibility of setting the furrow opener to any horizontal location on the bed to two locations, which are the most frequently used seed to seed gap.
Removing the possibility to set the rotary blades to any particular depth to only one setting, which is the most frequently used settings
Remove the seed and fertilizer dispensing ON/ OFF switch and keep them always on.
Training the operator on operating the BP, agronomic practices and maintenance.
Training the manufacturer in manufacturing, assembly and quality control.
Introducing a height adjustable bar on the handle of the 2WT to accommodate 5th -95th percentile operators.
Identifying quality manufacturers for manufacturing casting parts, plastic parts and rotary blades.
Create a tractor-look alike BP for higher aspirational value.
Design operator manuals and assembly manuals so that illiterates can also use it effectively.
The training workshop should be of adequate duration to ensure quality of operator training.
Training women as operators could also be looked upon.
7. Influence of the AM on workforce (Priority: High)
Certification for the operators and manufacturers to provide sense of pride and confidence.
Training program open to all, even illiterates.
8. Health & safety (Priority: High)
Design for assembly and disassembly

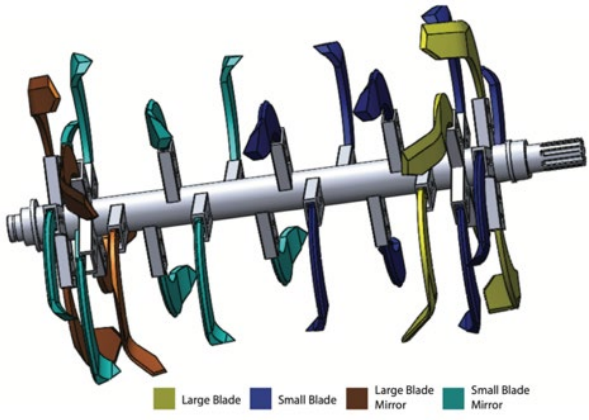
using M10 fasteners for frequently opened components, M5 for less frequently opened and M3 only if the fasteners have a space constraint.
No or minimal sharp edges.
Weight balancing for easing lifting of the BP.
Welding protective gear for the manufacturer's setup
9. Finance (Priority: Medium)
Modular design to target wider income range of users
Compensation package design for operators, LSPs, considering purchase, operation, maintenance, daily operational coverage possible, and hiring costs.
Government subsidy
10. Impediments due to infrastructure (Priority: High)
Spare parts availability
Repair and maintenance infrastructure
Assistance infrastructure
Manufacturing infrastructure
11. Reduction (Priority: Low)
Double seed dropping or no seed dropping to be minimized
Fertilizer application can be recalculated considering a close application
Soil preparation and planting cost to be calculated for the farmer in the new system.

Table A4. 9. Other ideas generated from the engineering, ergonomics and human-centered requirements identified during research and not mentioned in [Table A4. 7](#) above.

Other product ideas from engineering analysis	
1.	Rigid polypropylene (PP) delivery pipe to eliminate pipe bending and seeds getting jammed in it.
2.	The rigid PP pipe helps to improve seed to seed gap as irregular hits of the seed on the pipe walls is replaced by a spiraling motion of the seed in the pipe.
	
3.	Four sealed fertilizer dispenser boxes to attain fertilizer dispensing without the fertilizers becoming moist and paste-like.
	
4.	A precision seed meter for maize with geometry adjusted to the local seed varieties used.

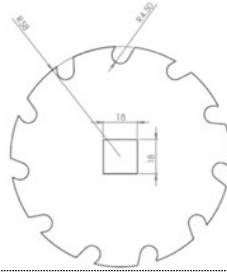

5. The operator's weight acts in better soil compaction.



6. A flail arrangement which keeps the furrow opener free from residue accumulation.

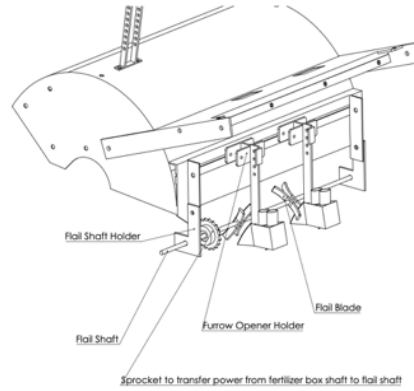

7. Due to additional weight of the operator, the BP will wobble less on the field. This will ensure better seed depth uniformity.

Other product ideas from human-centered design analysis

8. A seed and fertilizer storage box have been installed on the BP. This eliminates the need to frequently refill the BP with seeds and fertilizers.

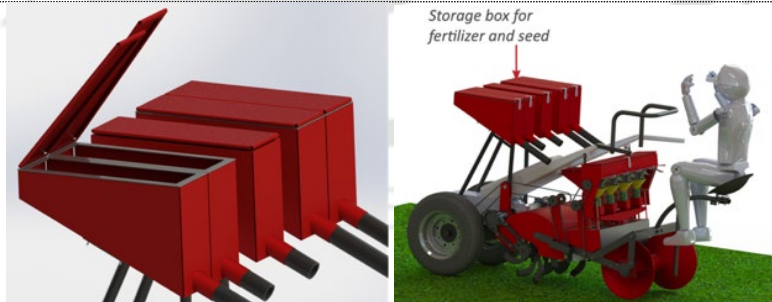

9. Mimic the aesthetics of a tractor powered machinery.



Other product ideas from ergonomics analysis

10. Height adjustable holding bars to suit ergonomic needs of operators of different heights.

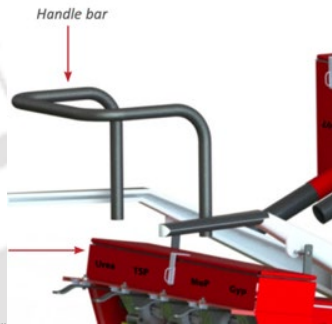

11. Storage box for fertilizer and seed shifts the weight towards front during operation leading to less effort in lifting it.

12. Designing for ease of manufacturing and assembly - assembling the components will need less awkward postures, number of people and time.

A4.2.3. Outline a design-oriented sustainability scenario (2.2)

In this step, we identified various polar ideas. [Figure A4. 38](#) summarizes some of them. For example, the PSS can be designed for short-term sustainable impact (effective bed planting) or long-term sustainable impact (conservation agriculture). The manufacturing of BP in the PSS can be done locally, or BP can be imported. The BP can perform only bed planting (plowing, seeding, and bed-making) or combine bed planting with fertilizer application. The PSS can target the minimum viable product, bed maker, or an augmented product, BP. The pros and cons of each of these polar ideas were next identified. This aided in sketching prospective PSS ideas. Four of these ideas are presented in [Figure 5.16](#), [Figure A4. 39](#), [Figure A4. 40](#), and [Figure A4. 41](#).

[Figure 5.16](#) presents PSS concept 1, around the idea of local manufacturing and assembly of all BP parts. To achieve the same, the PSS should have training workshops for enabling local manufacturers. Graphical manuals to aid training, manufacturing, and assembly considering illiterate, and semi-literate workers will also be required. The PSS design should also incorporate strategies to build local manufacturers' capability by helping them secure finance and building workshop infrastructure. A centralized raw material procurement network needs to be created. The other networks to be shaped will be for BP distribution, repair & maintenance, and spare parts supply. Further, to secure finance and market credibility, product certification and approval from BARI should be sought. A system for tracking BP and its components using identification numbers, feedback, and customer complaints needs to be designed. BP should be designed considering local manufacturers' capabilities and raw material availability. Jigs and fixtures for local manufacturers can be developed centrally and provided to them. Some components like plastic seed meter molds, precision casting molds, and rotary blades can be imported in bulk and supplied to each manufacturer.

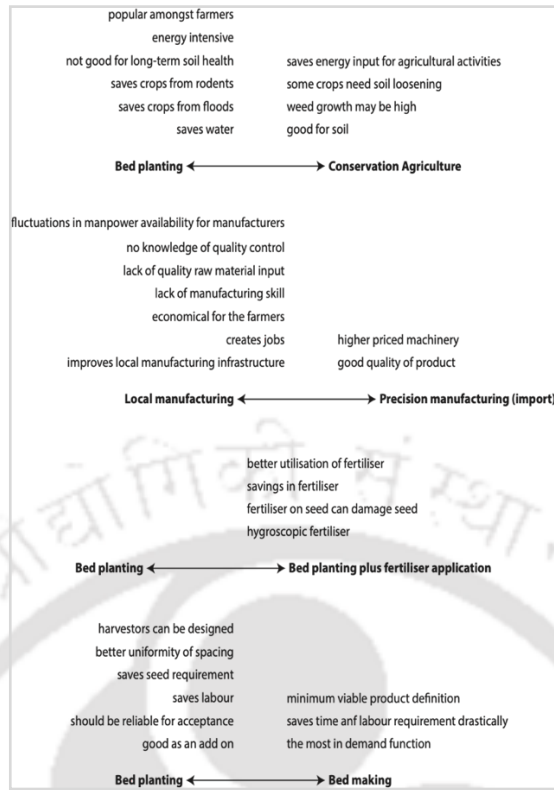

Figure A4. 38. Sample polarities ideas.

Figure A4. 39 presents PSS concept 2. The key idea behind PSS concept 2 is the scenario where BP components are imported and then assembled in Bangladesh. For this PSS, we need to train local manufacturers in assembling BP parts. The design team has to develop graphical manuals, jigs, and fixtures to aid illiterate and semi-literate workers in assembling, repairing, and maintaining BP. The PSS providers have to build a centralized system for BP parts procurement, distribution, repair and maintenance, and spare parts supply. A method for tracking BP and its components using identification numbers, feedback, and customer complaints needs to be designed. A unit for design, prototyping, and testing of BP needs to be set up. This unit will provide the BP part manufacturing company with the design data.

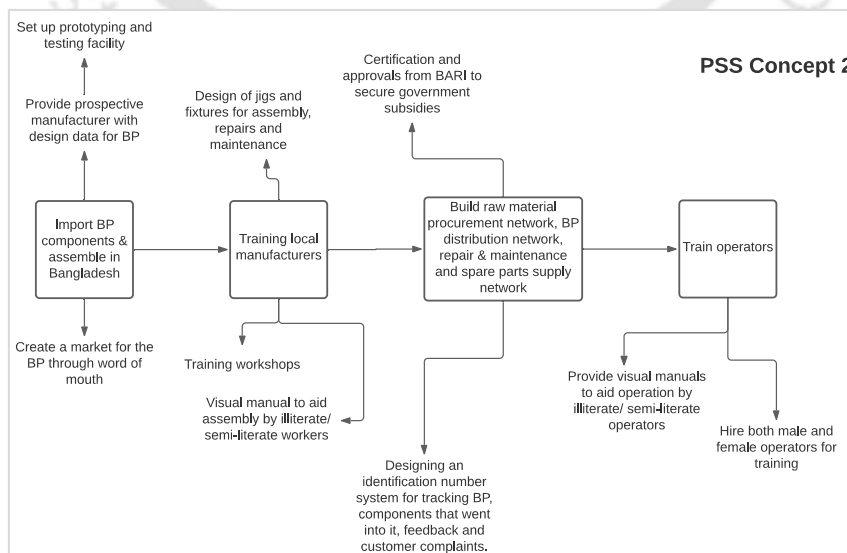

Figure A4. 39. PSS concept 2.

[Figure A4. 40](#) presents PSS concept 3. Here a repository of copyleft design of BP is created by iDE-B and CIMMYT. Any local manufacturer interested in manufacturing BP can use the repository data and start manufacturing. A design team and a facility for design, prototyping, and testing are set to generate the repository. The manufacturers are free to adapt the design to suit their local contexts and, thereafter, enrich the repository with new design data. Any manufacturer can again use this. The other aspects of this concept are similar to PSS concept 1.

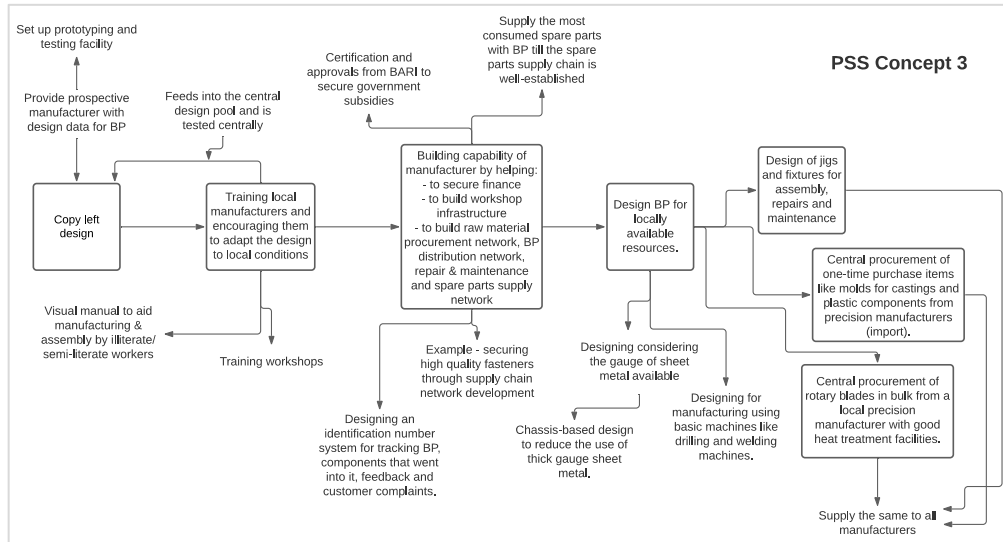

Figure A4. 40. PSS concept 3.

[Figure A4. 41](#) presents PSS concept 4. This concept suggests building a platform for farmers. The farmers with farms in proximity can plan their bed planting activity using it. A payment system can be designed to collect advance and final payments on the platform. The payment system can also incentivize collective use through discounts for group usage. To achieve collective use, BP should be designed for operation while seated. This will ensure that the operator is less taxed and can cover a substantial farm area in a day. A seed and fertilizer storage box mounted on BP will also reduce the filling time and increase the daily farm coverage. LSPs, farmers, and operators will have to be trained for using the said platform.

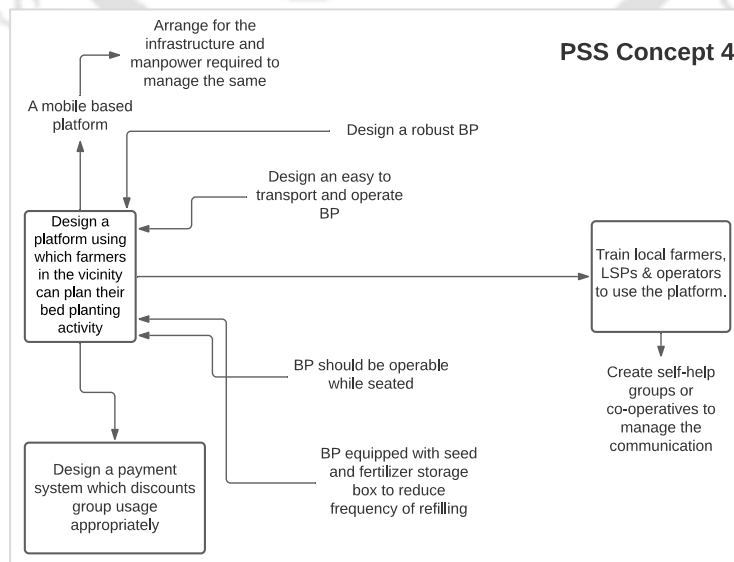

Figure A4. 41. PSS concept 4.

A4.3. Designing system concepts (3)

This stage aims to design system concepts using the design-oriented sustainability scenario outlines from (2.2), design the stakeholder and systems map for each concept, and assess them on the three sustainability dimensions. The three processes for this stage are (3.1) *selecting clusters and single ideas*, (3.2) *developing system concepts*, (3.3) *environmental, socio – ethical, and economic assessment* ([Figure A4. 42](#)). The results of the processes (3.1), (3.2), and (3.3), the gaps, and proposed addition are summarized in [Table 5.6](#).

A4.3.1. Selecting clusters and single ideas (3.1)

The PSS concept outlines from (2.2) were plotted on polarities diagrams. The polarities diagrams were mapped using polar sustainability scenarios for the system. For example, one of the polarities diagrams presented in [Figure 5.17](#) uses an environmental sustainability criteria *system life optimization on the Y-axis* and social sustainability criteria *empower/ valorize local resources* on the X-axis of the polarities diagram. The polar situations on the Y-axis are a robust PSS vs. a weak PSS. The polar scenarios on the X-axis are global to local vs. local empowerment. The concept plotting helped quick qualitative assessment of the concepts and ideas. This aided in selection of the most prospective ideas and idea clusters.

A4.3.2. Developing system concepts (3.2)

From the prospective ideas and idea clusters, identified in (3.1), we initiated design of PSS concepts. The concepts were defined by plotting stakeholders and the energy flows between them and the offerings of the PSS. In this section, we describe only the final concept. This concept is completely detailed and designed in (5.1). [Figure 5.19](#) shows the final PSS stakeholders and [Figure 5.20](#) shows the energy flows between the stakeholders. The final PSS has four new stakeholders: Precision Component Manufacturer, Other Local Manufacturers, Other Local Manufacturers' workers, and Repair Personnel. The role of iDE-B and CIMMYT in this new system is proposed to be that of an enabler, coordinator and trainer. They train the operators, manufacturers, manufacturers' staff, and repair personnel. They also advertise the benefits of the product amongst all stakeholders and try to secure a subsidy for it from the government and endorsement from BARI for its quality and performance. They also provide a license to various manufacturers for making the BP. They charge no license fees as their expenses for the work comes from the CSISA-MI project. JE manufactures the BP after its workers are trained. Precision parts like casting and plastic components are bought from Precision manufacturers, rotary blades from current Chinese suppliers, and other raw materials of the appropriate quality from local vendors and scrap dealers. The BP will thereby be sold to the dealer who sells it to LSP. The LSPs can operate the BP themselves or with hired operators. The farmers pay for the service. The LSPs contact the local spare parts shops and workshops, to which JE has supplied spares for repair and maintenance using the services of repair personnel. In the meantime, other manufacturers are identified and trained and can join the brigade of JE in different parts of the country. The new parts developed for region-specific contexts can be mutually shared as part of an obligation due to the manufacturing license from iDE-B and CIMMYT. Thus, the providers' partnership has grown in this proposed model and involves stakeholders who can cater to the needs of manufacturing, repair, maintenance, training, and operation.

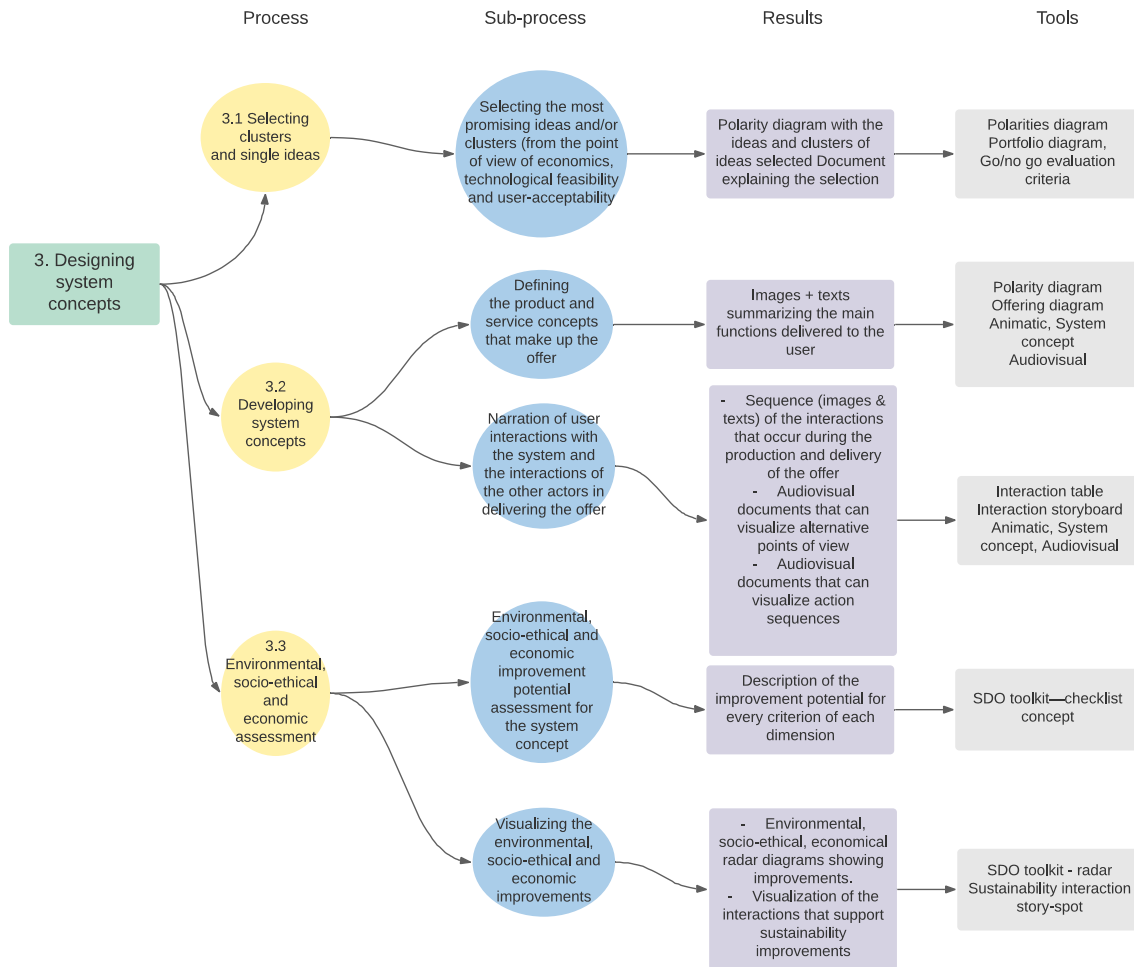

Figure A4. 42. Designing system concepts - (3.1) Selecting clusters and single ideas, (3.2) Developing system concepts, (3.3) Environmental, socio-ethical and economic sustainability. Source: (Vezzoli et al., 2014).

The offering diagram (Figure 5.21) presents the offering of the final PSS. The offering is defined in terms of the core functions, the basic functionalities, the added-value functionalities, and the PSS's sub-functionalities. Those were conceptualized using the trade-off decision knowledge gathered through the polarity diagrams. The core function is the primary performance of the PSS that synthesizes its essence. The basic functionalities are those necessary to offer the core function. The added-value functionalities can be connected to the core functions to enrich and augment the value of the PSS offering. The sub-functionalities describe the way the PSS functionalities will be delivered. The final PSS's core functions consist of three modules: a bed planting system, training for operators, and training for manufacturers. The basic functionality for bed planting is on-demand plowing and bed-making. For training operators, they are training the trainers and design a training manual. They are manufacturer identification, training the trainers, and developing a training manual for training the manufacturers. Added-value functionalities for bed planting are the capability to plant seeds and apply fertilizer. Gaining certifications and endorsements from the government and institutes like BARI add value to the operators and manufacturers' training program. The basic functionalities needed to offer the core function of bed planting are after-sales services, funding, loan or subsidy availability, creating a network of LSPs, and service and repair ecosystem provision. The basic functionalities needed to offer training are spreading the word about it through word of mouth and other advertisement channels, recruiting operators, manufacturers, and trainers for training, and creating appropriate partnerships with other training agencies or certification and endorsement agencies.

A4.3.3. Environmental, socio-ethical and economic assessment (3.3)

Herein the “SDO toolkit - checklist concept” was used to describe the improvements made in each of the PSS concepts developed in (3.2). After that, a qualitative assessment of the redesigned PSS concepts was done on all three sustainability dimensions per the stakeholders' priorities set at the beginning of the project. The SDO toolkit aided the visualization of the qualitative assessment using radar diagrams. Due to time and resource constraints, the assessment was done by the researcher only. PSS stakeholders' involvement in the assessment process could have provided better visualization of the improvements and worsening. [Figure 5.23](#) shows the radar diagrams for the final PSS. Section [A4.5.2](#) presents the sustainability improvements made in the final PSS design and the qualitative assessment.

A4.3.4. Addition to (3.3): SAC checklist-aided assessment

(Proposed addition to fill the gap - Sustainability in the agricultural context)

To study the impact of the PSS concepts developed in 3.2 on agronomic sustainability, we analyzed the sustainability impact of each PSS concept using the SAC checklist. The visual representations of the improvement analysis results for the final PSS is presented through a radar diagram ([Figure 5.23](#)) and section [A4.5.2](#) presents the sustainability improvements made in the final PSS design and the qualitative assessment.

A4.4. Product designing and engineering (4)

This is a new stage, introduced in MSDS, to focus on the environmental sustainability of a product through LCD of AM. Herein the goal is to design and engineer the BP, and conducting sustainability assessment of the redesigned BP using the ICS toolkit and the SAC checklist. This stage's two processes are (4.1) designing and engineering the product concept and (4.2) environmental, socio – ethical, and economic assessment ([Figure A4. 43](#)).

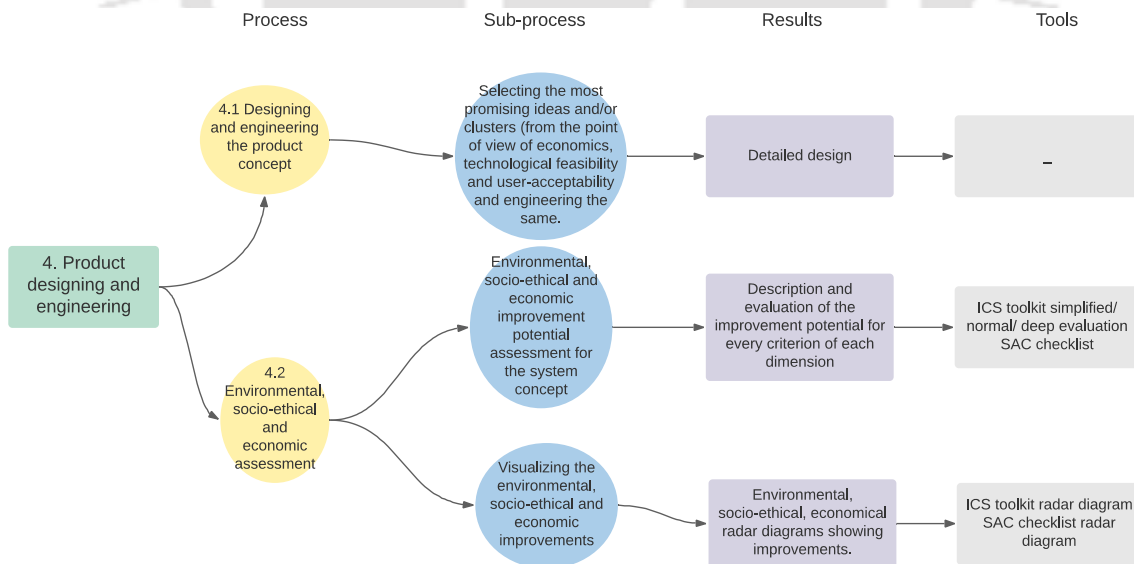

Figure A4. 43. Product designing and engineering - (4.1) designing and engineering the product concept and (4.2) environmental, socio – ethical, and economic assessment.

A4.4.1. Designing and engineering the product concept (4.1)

I designed the BP with the support of the engineering team at iDE-B. To design BP, the ideas generated with the aid of the *SDO toolkit - orient the concept* ([Table A4. 6](#)), *ICS toolkit ideas board* ([Table](#)

A4.7) and SAC ideas board (Table A4.10), were used. Figure A4.44 shows the final BP parts. The design mimics the visual appeal of a tractor and looks robust. Thus, it is expected to score high on the aspiration factor. We observed this during the field trials when villagers came enquiring about where they can purchase the product. The redesigned rotary blade arrangement (Table A4.7, Idea 27) was observed to pulverize even unplowed soil (Figure 5.2) in one pass. Due to improved efficiency in soil pulverization, the bed height could be raised to 15 cm, as BARI recommended. Improved efficiency also helped run the machine with an operator's additional load and 30 kg of seed/ fertilizer on it (Figure 5.24). The redesigned BP can be operated while sitting on it or walking beside it. It can be transported on its wheels from one village to another. The new seed metering plate plus finger arrangement (Table A4.7, Idea 1) and seedbox inclination (Table A4.7, Idea 20) reduced seed misses and double droppings to merely 1.7%. Sealed compartmentalized fertilizer boxes (Table A4.11, Idea 3) have been designed to dispense the four fertilizers separately without turning them paste-like. In order to reduce the number of meters required, a delivery divider (Table A4.7, Idea 18) has been designed. The delivery pipes have been redesigned to ensure better seed to seed gap accuracy (Table A4.7, Idea 4). A seed and fertilizer storage box (Table A4.7, Idea 30) has been designed so that constant refilling of metering and dispensing boxes can be eliminated. Also, the seeds and fertilizers' additional weight adds weight towards the front, making it easier to lift the BP.



Figure A4.44. BP parts.

A4.4.2. Environmental, socio-ethical and economic assessment (4.2)

The ICS toolkit's *simplified evaluation* was used to qualitatively evaluate the environmental sustainability improvement or worsening of the redesigned product over its life-cycle stages as per the priority set at the beginning of the project. The SAC checklist helped in the sustainability performance evaluation of all three dimensions for BP's agronomic impact as per the priority set at the beginning of the project. The ICS toolkit's *simplified evaluation* and the SAC checklist direct the checking of the concept on the improvements made on a four-point scale:

- Worsening
- = NO improvement
- + INCREMENTAL improvement

++ RADICAL improvement

[Figure 5.26](#) presents the radar diagram visualizing the environmental sustainability improvements due to BP design. The assessments have been done based on the BP prototype's limited trials. [Figure 5.23](#) presents the SAC checklist aided improvement mapping for BP and the PSS. The key features in BP design that can bring forth the environmental sustainability improvements are listed in .

Table A4. 10. The key features in BP design that can bring forth the environmental sustainability improvements.

Criteria	Sub-criteria	Key Features	Priority	Improvement
Environmental Sustainability	Use extension/intensification	<ul style="list-style-type: none"> The seed metering and dispensing mechanism redesign helped in creating a reliable BP. Designing considering ease and ergonomics of repair and maintenance aided in facilitating maintenance. BP is designed as a basic product plus additions - fertilizer metering and dispensing unit, seat plus rear wheel, and storage box plus structure; aid in up-gradation and adaptation to various usage scenarios. Simplification of the user interfaces to aid in ease of use and improve the reliability of BP operations. Possibility to sit and use BP, shifting the weight of BP towards the front (aids lifting BP at the end of each line) and ability to transport it using its wheels improves use intensity. 	High	++
	Material consumption reduction	<ul style="list-style-type: none"> Chassis-based design reduced the non-structural component weight. The redesigned rotary blades have a longer life. Clubbing the precision and mass flow seedboxes reduced material consumption. The delivery divider aid in dispensing two lines of seeds or fertilizers using one metering unit. 	High	++
	Energy consumption reduction	<ul style="list-style-type: none"> The redesigned rotary blades are efficient and reduce energy consumption. The 9HP 2WT based BP could form 15 cm high beds as a result of the design. The elimination of the possibility to set the bed shaper and scrapper outside the cutting width reduced frictional energy losses. Chassis-based design and other features listed in "material consumption reduction" reduced BP's dead weight and saved energy consumption. Shifting BP's weight towards the front aid in the easier lifting of BP, thus consuming less muscle energy. 	High	++
	Material life extension	<ul style="list-style-type: none"> The redesigned rotary blades have a longer life. The elimination of the possibility to set the bed shaper and scrapper outside the cutting width improves its life. The aluminum seed meter has a longer life than plastic ones. 	High	++

		• The use of quality fasteners improves their life and that of parts where it is used.		
	Toxicity reduction	•	Medium	=
	Resource conservation/ biocompatibility	•	No	=

A4.5. System designing and engineering (5)

Herein the PSS selected at the end of stage three is detailed and engineered to take it up for implementation. Stage 5 consists of two processes, (5.1) *detailed system design* and (5.2) *environmental, socio-ethical, and economic assessment* ([Figure A4. 45](#)). The results of the processes (5.1) and (5.2), the gaps, and proposed addition are summarized in [Table 5.8](#).

A4.5.1. Detailed system design (5.1)

Of all the competing PSS concepts generated in (3.2), the most promising concept was selected post sustainability assessment in (3.3). This concept along with the BP design were then taken forward to design and detail the final PSS. The final PSS's stakeholders, their energy flows and the offering diagram are presented in section [A4.3.2](#).

A4.5.2. Environmental, socio-ethical and economic assessment (5.2)

Here using the *SDO toolkit - checklist concept* the final PSS concept was assessed for improvements on all three dimensions of sustainability using a four-point scale:

- Worsening
- = NO improvement
- + INCREMENTAL improvement
- ++ RADICAL improvement

[Figure 5.23](#) presents the radar diagrams visualizing the environmental, social and economic sustainability improvements due to the PSS design. The assessments have been done based on the proposed PSS design features and BP's limited trials. The key features in the PSS design that can bring forth the sustainability improvements are presented in [Table A4. 11](#).

A4.5.3. Addition to (5.2): SAC checklist-aided assessment

(Proposed addition to fill the gap - Sustainability in the agricultural context)

To fill the sustainability in the agricultural context gap, a SAC checklist aided assessment of the final PSS was done. The assessments have been done based on the proposed PSS design features and BP's limited trials. The key features in the PSS design that can bring forth the sustainability improvements are presented in [Table A4. 11](#).

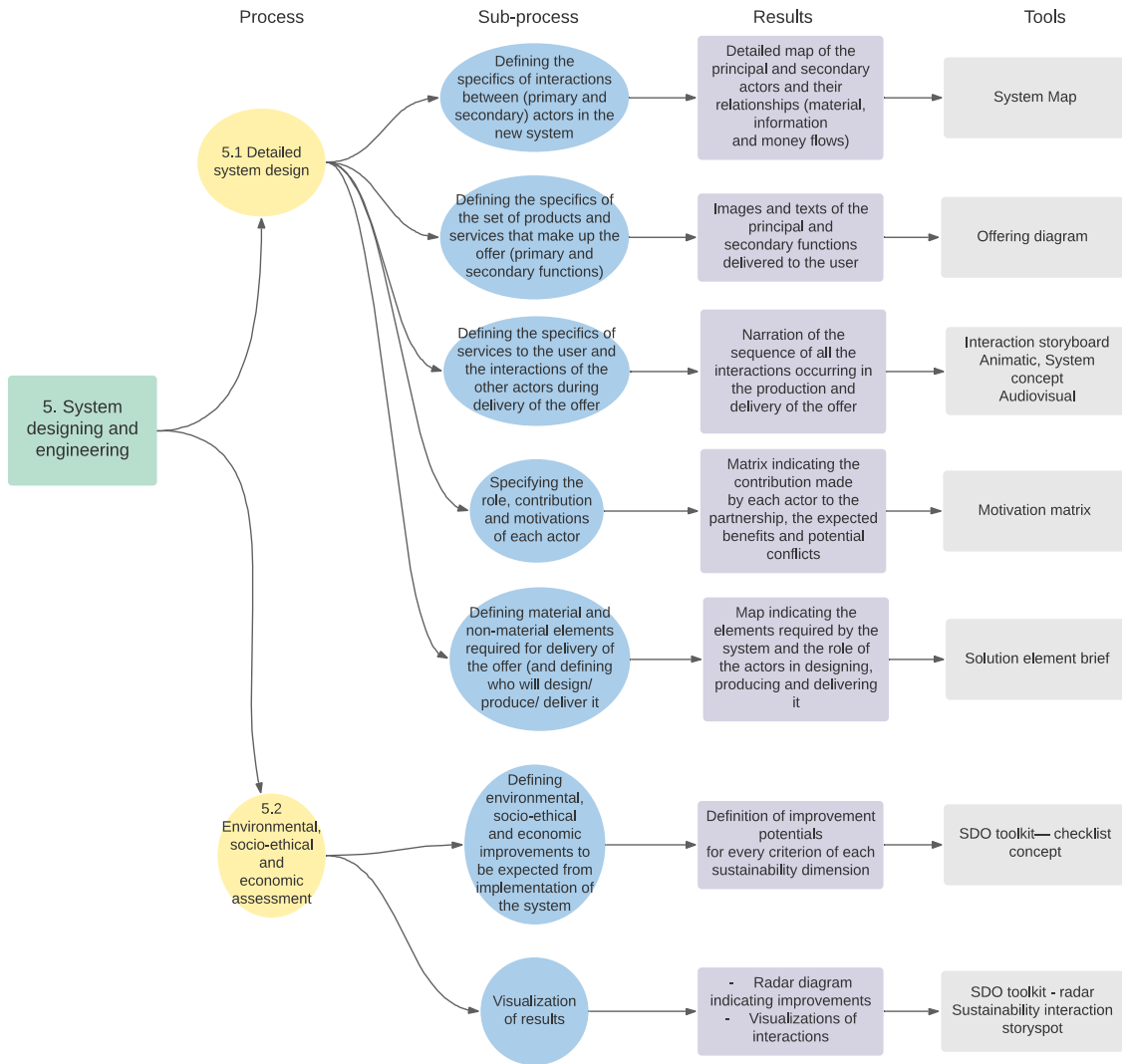

Figure A4. 45. System designing and engineering - (5.1) Detailed system design, (5.2) Environmental, socio-ethical, and economic assessment. Source: (Vezzoli et al., 2014).

Table A4. 11. The key features in the PSS design that can bring forth the sustainability improvements.

Criteria	Sub-criteria	Key Features	Priority	Improvement
Environmental Sustainability	System life optimization	<ul style="list-style-type: none"> • Procurement of quality fasteners, chains, and sprockets from Indian manufacturers. • The rotary blade design improved its life. • Provision of most frequently needed spare parts with BP. • Simplification of user interfaces and graphical manuals reduced the possibility of setting BP in wrong settings and damaging it. • Training programs for different stakeholders. <ul style="list-style-type: none"> • Modular BP • Copyleft design open for co-development. • Robust and ergonomically designed BP. <ul style="list-style-type: none"> • Tractor look-alike BP. • Stakeholder base creation – LSPs, operators, spare parts, repair and maintenance providers, manufacturers. 	High	++

	Transportation/ distribution reduction	<ul style="list-style-type: none"> • Transportable BP. • BP with a removable seat. • Weight balancing of BP. <ul style="list-style-type: none"> • An identification system for tracking BP sold in the market. 	High	++
	Resource reduction	<ul style="list-style-type: none"> • Centralized bulk procurement of precision components from large scale manufacturers. • Training/ marketing the fact that seeding and fertilizer application using the BP will save on the amount of seed and fertilizer requirement. 	High	+
	Waste minimization/ valorization priority	<ul style="list-style-type: none"> • Training the operator in understanding the soil. • Creating a system for taking back the worn-out blades and recycling the same. 	Low	+
	Conservation/ biocompatibility	Nil	No	=
	Toxicity Reduction	<ul style="list-style-type: none"> • Protective gear for the manufacturer's staff and training on the potential risks and prevention techniques. • Design of mudguards and BP's overall configuration so that a lesser amount of soil dust is produced. • Training the operator to understand the soil conditions that are inappropriate for bed planting. 	Medium	+
Socio-Ethical Sustainability	Improve employment and working conditions	<ul style="list-style-type: none"> • Provide a seating alternative for operating BP to optimize human energy required. • Provide seed and fertilizer storage to reduce the constant filling and the need for a co-operator. • The weight balance of the BP so that it is easy to lift. <ul style="list-style-type: none"> • Training operators. • Fair compensation package. • Protective gear for the manufacturer's staff and training on the potential risks and prevention techniques. • Design of mudguards and BP's overall configuration so that a lesser amount of soil dust is produced. 	High	++
	Improve equity and justice in relation to stakeholders	<ul style="list-style-type: none"> • A robust supply system consisting of the BP, spare parts, training - operation & maintenance. <ul style="list-style-type: none"> • Fair compensation package. • Design of BP for the manufacturing staff's safety. 	High	+
	Enable a responsible and sustainable consumption	<ul style="list-style-type: none"> • A warranty system that holds the manufacturer responsible for the problems in the machine. <ul style="list-style-type: none"> • Provision of the contact number of the manufacturer on the BP for resolving queries. • Government subsidy for greater confidence in buying. • Endorsement/ certification from BARI, which shows that BP has been tested and cleared for sale. 	High	+
	Favor/ integrate weaker and marginalized strata	<ul style="list-style-type: none"> • Selling the BP as modules to make it accessible to a broader group with varying purchasing power. • Organizing training programs for women operators. 	Medium	+

		<ul style="list-style-type: none"> • Training for manufacturers or want-to-be manufacturers to develop the manufacturing strength of the region. 		
	Improve social cohesion	Nil	No	=
	Empower/valorize local resources	<ul style="list-style-type: none"> • Training local unemployed youth as an operator, maintenance personnel, or manufacturer. • The utility of 2WT will improve and generate additional income for owners. 	High	+
Economic Sustainability	Market position and competitiveness	<ul style="list-style-type: none"> • iDE-B and CIMMYT's network to create a robust training, manufacturing, and distribution channel. 	High	+
	Profitability/added value for companies	<ul style="list-style-type: none"> • Improves the manufacturing capability of the region. • Outsources precision manufacturing. • Creates a channel for repair, maintenance, spare parts, and collection of damaged/ broken parts for recycling. 	Medium	+
	Added value for customers	<ul style="list-style-type: none"> • Timely field preparation. • Reduction in seed and fertilizer requirement. • Lower operational cost. • Opens the possibility of mechanized weeding, harvesting, intercropping, and other plant care activities. • Alternate employment opportunities. • Entrepreneurial opportunities. • Pride of owning a tractor look-alike BP. 	High	++
	Long term business development/ risk	Government subsidy and certifications from government bodies.	Low	+
	Partnership/cooperation	<ul style="list-style-type: none"> • A strategic partnership with different types of manufacturers - small scale, large scale. 	High	+
	Macro-economic effect	Nil	No	=
	Impact on Agricultural Practice	Short-term & immediate effect	<ul style="list-style-type: none"> • Adequate pulverization and improved bed shaper assembly design ensure the formation of 15 cm high beds. Thus, the beds will retain its height for more extended duration post irrigation and floods, giving the crops a better chance of survival and growth. • Soil dust generation is reduced through BP configuration, mudguard, and flail design. The flail arrangement ensured that the furrow opener would not get blocked with residue. Thus, the operator will not remove the mudguard for constant visual monitoring of the furrow opener. • Adequate soil compaction is produced around the seeds through improved soil pulverization due to the rotary blades, better soil accumulation due to the bed shaper, and weight application on top of the bed shaping roller by sitting over it while bed planting. • Application of basal fertilizer beside the seed. 	Medium
Long term effect		Nil	No	=

Bearing of the AM on the agro-system activities	<ul style="list-style-type: none"> • Precision seeding redesign reduced the seed misses and double seed falling. • Delivery pipe redesign improves seed to seed gap consistency. • Reduction in cost and operation time as the redesigned rotary blades could accomplish all tasks in one pass. 	Medium	+
Impact on sustainable farming practices	Nil	No	=
Auto-optimization of functioning	Nil	No	=
Machine Typology Efficiency	<ul style="list-style-type: none"> • Reduction in rear side weight leads to a decrease in muscle effort of the operators. • Option to sit and operate the BP reduces operator effort. • Optimized rotary blades, bed shaper arrangement and all components' weight reduce the fuel consumption. 	High	++
Impact due to the AM induced pre-processing needs	<ul style="list-style-type: none"> • Easy mounting and removal of the rear wheel and seat. • Training the operator to know the right soil conditions for bed planting and the number of passes before bed planting. 	High	+
Impact due to the AM induced post-processing needs	<ul style="list-style-type: none"> • Transporting BP made easy through the rear wheels and seat attachment. 	Medium	+
Influence of the workforce on the AM	<ul style="list-style-type: none"> • Simplification of the user interfaces and manual development for effective use by illiterate and semi-literate operators. • Training for operators and manufacturers. 	High	++
Influence of the AM on workforce	<ul style="list-style-type: none"> • Training for operators and manufacturers. • Organizing training programs for women operators. 	High	++
Health & Safety	<ul style="list-style-type: none"> • Design for ease of manufacturing, assembly, operation, repair, and maintenance. • Designed to reduce the effort of operators. • Designed to reduce dust generation. 	High	+
Finance	<ul style="list-style-type: none"> • Modular design to target a wider income range of users. 	Medium	+
End-of-life	Nil	No	=
Impediments due to infrastructure	<ul style="list-style-type: none"> • Spare parts, repair, and maintenance made available. 	High	++
Reduction	<ul style="list-style-type: none"> • Double seed dropping or no seed dropping minimized. • Fertilizer application optimized. • Soil preparation and planting costs and time were reduced. 	Low	+

Appendix 5

Nineteen indicator-based sustainability assessment methods from agriculture

Table A5. 1. Comparison of nineteen indicator-based sustainability assessment methods from agriculture based on their aim, target group, and sustainable agriculture definition.

Approach	Aim	Target Group	Definition of Sustainable Agriculture	Assessment Level	Assessment Procedure	Goal Setting
AVIBIO - AViculture BIOlogique (Pottiez et al., 2012)	To assess sustainability at the organic poultry production chain scale over the next 10 years.	Farmers and the poultry industry, research and extension, state and local authorities	Generate and safeguard income, and share added value between stakeholders; Guarantee supply and market access; Enhance local employment; Meet citizens' expectations; Ensure the sustainability of production tools; Strengthen the local network; Minimize the use of resources; Reduce pollution; Enhance biodiversity	Farm, Chain	Scoring System, Aggregation	Participatory (hatching to distribution; research, development and training; professional and not-for-profit organization; State and local authorities)
COSA - Committee on Sustainability Assessment (COSA, 2013 ; Giovannucci et al., 2008)	Data gathering and analysis process so that farmers and other stakeholders can assess and predict what sort of social, economic and environmental outcomes they may have by implementing different sustainability initiatives like Fair Trade, Organic, Utz Certified and Rainforest Alliance	Didactic or farm management tool for use by farmers and their organizations	Income; production, processing and marketing costs; access to credit; farm management; quality levels; market access; profitability; energy management (amount and kinds of energy used); water management (evidence of water conservation practices); soil resource management (erosion and coverage or prevention); biodiversity and resource management (percentage, quality and diversity); pollution reduction (record keeping, products and chemicals applied, IPM); recycling and re-using (systems in place); carbon sequestration (vegetation density and quality).; health and safety; working hours and wages; basic rights; community relations; farmer perception and satisfaction.	Farm	Multi-criteria analysis approach	Top-down (theory)
Development and evaluation of an on-demand sustainability	Supporting the learning process of the farmer	Farmers	Political, social, cultural, historical and environmental context in which the project occurs	Farm	Scoring System, Aggregation	Participatory

Approach	Aim	Target Group	Definition of Sustainable Agriculture	Assessment Level	Assessment Procedure	Goal Setting
tool in Flanders (Coteur et al., 2014)						
A methodological approach to assess and compare the sustainability level of agricultural plant production systems (Dantsis et al., 2010)	Assess and compare sustainability of the agricultural sector on the thirteen geographical regions of Greece	-	Crop management practices; economic performance; social characteristics of each agricultural household.	Farm, Regional	Scoring System, Aggregation	Top-down (theory)
DSI - Dairyman Sustainability Index (Elsaesser et al., 2015)	Monitoring the impact of management plans on the development of sustainability on farms or a group of farms in a defined region	Dairy farms	Education - Basic education; Training courses; Working conditions - Personal satisfaction (work-life-balance? How often do you feel stressed? Are you happy with your salary? Activities outside the farm?); Work load per family labor unit; Holidays; Free time; Farm continuity -Preparation of farm succession; Is there a potential successor?; Social role and image: relation to neighborhood, reputation within the area, organization of public events on the farm, etc.; N balance (kg/ ha); N balance per kg milk (kg per 1000 kg milk); N efficiency (%); P balance per ha (kg/ ha); P balance per kg milk (kg per 1000 kg milk); P efficiency (%); Payments for environmental activities; Greenhouse gas emissions (kg CO2-eq per Mg milk); Income € per 100 kg milk; Income € per family worker; Farm income € per family labor unit; Dependency on subsidies %; Exposure to price fluctuations %	Farm	Multi-annual data-set	Bottom-up (Stakeholders) and top-down (theory)
FARMSMART (Tzilivakis and Lewis, 2004)	To enable farmers to identify the key areas where they need to	Farmers	The rural economy indicators; Farm management systems; Input use; Resource use;	Farm	Actual measurements and	Top-down (theory)

Approach	Aim	Target Group	Definition of Sustainable Agriculture	Assessment Level	Assessment Procedure	Goal Setting
	assess their farm performance and make improvements considering the farm type and management practices and linked back to the national level where feasible.		Conservation value of agricultural land		Statistical data	
FESLM - Framework for the Evaluation of Sustainable Land Management (Smyth et al., 1993)	To guide analysis of land use sustainability, through a series of scientifically sound, logical steps. It is integrative (considers all interacting factors), concerned with evaluation, systematic	Researcher and policy makers	Productivity; Security; Protection; Viability; Acceptability	sustainable land management - capturing changes in typologies of areas and development over time	Reference values and thresholds	Top-down (theory)
IDEA - Indicateurs de Durabilité des Exploitations Agricoles (Zahm et al., 2008)	To provide an operational tool for sustainability assessment at farm level	Planners, policy-makers, researchers, farmers and farmer organizations	Economic viability; Social livability; Environmental reproducibility	Farm	Scoring System, Aggregation	Top-down (theory)
ISAP- Indicator of Sustainable Agricultural Practice (Rigby et al., 2001)	To operationalize agricultural sustainability in order to support policy making	Researcher and policy makers	Minimization of off-farm inputs; Minimization of non-renewable resources; Maximization of natural biological processes; Promoting local biodiversity; Enhancing farmers' quality of life Increasing farmers' self-reliance; Sustaining the suitability/ profitability of the farm; Improving equity; Meeting society's needs for food and fiber	Farm	Scoring System, Aggregation	Top-down (theory)
KSNL - Criteria for sustainable farming (Ehrmann and Kleinhanß, 2008)	Recording and assessing ecological damage by agricultural enterprises, criteria for economic sustainability and social compatibility	Farms, Consultancy & decision-making agencies	KUL (Criteria for an Ecologically Compatible Land Management), KWL (Criteria for economically sustainable farming), KSL (Criteria for socially compatible farming).	Farm	Measurement of actual data, Comparison against tolerance limits, plotting on uniform rating scale	Top-down (theory)

Approach	Aim	Target Group	Definition of Sustainable Agriculture	Assessment Level	Assessment Procedure	Goal Setting
MESMIS - Framework for Assessing the Sustainability of Natural Resource Management (López-Ridaaura, 2002)	Systemic, participatory, interdisciplinary and flexible framework for evaluating sustainability in the context of peasant agriculture and peasant Natural Resource Management Systems.	Farmers	Productivity, stability, reliability, resilience, adaptability; equity; self-reliance (self-empowerment)	Farm, local	Indicators integrated through mixed (qualitative and quantitative) techniques and multicriteria analysis	Interdisciplinary, Top-down (theory)
MMF - Multiscale Methodological Framework (Keulen et al., 2005)	To assess multiscale sustainability with emphasis on peasant agriculture and natural resource management.	Researcher and policy makers	Productivity; Stability; Resilience; Reliability; Adaptability	Multiscale level with an emphasis on peasant agriculture and natural resource management	Stakeholder evaluation	Bottom-up (Stakeholders)
MOTIFS - Monitoring Tool for Integrated Farm Sustainability (Meul et al., 2008)	Monitoring, communication, learning, and management function	Farmers	Use of inputs; quality of natural resources; biodiversity, referring to ecological sustainability; profitability; productivity and efficiency; risk, referring to economic sustainability; internal social sustainability, which takes the well-being of the farmer and his family as a focal point; external social sustainability, which is related to the expectations of the society vis à vis agriculture; disposable income, referring to social sustainability; entrepreneurship.	Farm	Scoring System, Aggregation	Combination of transdisciplinary (vision and themes) and top-down process (sub-themes and indicators)
PG - Public Goods Tool (Gerrard et al., 2012)	Providing a “public good” beyond the simple production of food, adjusted with farm related sustainability aspects	Farmers, policymakers	Farming provides public goods beyond production of food only	Farm	Scoring System, Aggregation	Combination of stakeholder involvement and top down
RISE - Response Inducing Sustainability Evaluation (Grenz, 2011 ; Grenz and	To provide a simple and cheap but holistic tool to: 1) evaluate the degree of sustainability at farm level	Farmers	Productivity Competitiveness; Efficiency; Protection and improvement of the natural environment and socio-economic conditions of local communities	Farm	Scoring System, Aggregation	Top-down (theory)

Approach	Aim	Target Group	Definition of Sustainable Agriculture	Assessment Level	Assessment Procedure	Goal Setting
Sereke, 2017; Grenz et al., 2009)	2) visualize potentials and failures, thus inducing management responses					
SAFA - Sustainability Assessment of Food and Agriculture Systems (FAO, 2013b)	To assess sustainability for decision-making and also for monitoring, progress-tracking and evaluation of sustainability impacts in the food and agriculture sector	Food and agricultural enterprises, organizations, governments	Sustainable development in agriculture is environmentally non-degrading, technically appropriate, economically viable and socially acceptable	Farm, Chain	Scoring System, Aggregation	Top-down (theory)
SAFE - Sustainability Assessment of Farming and the Environment (Van Cauwenbergh et al., 2007)	To identify, develop and evaluate agricultural production systems, techniques and policies	Researcher and policy makers	Biological diversity; Productivity; Regeneration Capacity; Vitality; Ability to function	Agro-ecological system - effect of farm activities at plot, farm and regional level	Reference values and thresholds	Top-down (theory)
SSP - Sustainability Solution Space for Decision Making (Binder and Wiek, 2007; Binder et al., 2012; Wiek and Binder, 2005)	To identify the sustainability solution space in which stakeholders can define strategies and the system remains or becomes more sustainable	All stakeholders which can affect the sustainability of the system; planners, farmers, policy makers	Theory based combined with a trans-disciplinary process. Includes: multidimensionality and multi-functionality	Largest range within which a sustainable development can take place	Indicator ranges	Transdisciplinary
Development and application of a multi-attribute sustainability function for Dutch dairy farming systems (Van Calker et al., 2006)	To determine an overall sustainability function	Dutch dairy farming systems	Economic sustainability – profitability; Internal social sustainability- Working conditions; External social sustainability – food safety, animal welfare, animal health, landscape quality; Ecological sustainability – Eutrophication, groundwater pollution, dehydration of the soil, acidification, global warming, eco-toxicity.	Farm	Goal programing to aggregate assessments of the experts and/or stakeholders.	Experts determined the utility function for economic and environmental dimension. Stakeholders (producers, consumers, industrial producers and policy makers) identified the utility function for social dimension.

Appendix 6

Literature used to generate the list of critical features, diagnostic criteria, rapid sustainability assessment indicators and design guidelines for the environmental dimension

1. Thornhill, I., Ho, J.G., Zhang, Y., Li, H., Ho, K.C., Miguel-Chinchilla, L., Loiselle, S.A., 2017. Prioritising local action for water quality improvement using citizen science; a study across three major metropolitan areas of China. *Sci Total Environ* 584-585, 1268-1281.
2. Salem, G.S.A., Kazama, S., Shahid, S., Dey, N.C., 2017. Groundwater-dependent irrigation costs and benefits for adaptation to global change. *Mitig. Adapt. Strateg. Glob. Chang.* 23(6), 953-979.
3. O’Keeffe, J., Moulds, S., Bergin, E., Brozović, N., Mijic, A., Buytaert, W., 2018. Including Farmer Irrigation Behavior in a Sociohydrological Modeling Framework With Application in North India. *Water Resources Research* 54(7), 4849-4866.
4. Jourgholami, M., Khajavi, S., Labelle, E.R., 2018. Mulching and water diversion structures on skid trails: Response of soil physical properties six years after harvesting. *Ecol. Eng.* 123, 1-9.
5. Rodias, E., Berruto, R., Busato, P., Bochtis, D., Sørensen, C., Zhou, K., 2017. Energy Savings from Optimised In-Field Route Planning for Agricultural Machinery. *Sustainability* 9(11).
6. Ayodele, T.R., Ogunjuyigbe, A.S.O., Olateju, B.E., 2018. Improving battery lifetime and reducing life cycle cost of a PV/battery system using supercapacitor for remote agricultural farm power application. *Journal of Renewable and Sustainable Energy* 10(1).
7. Thabit, M., Guo, Z.-l., 2011. Retrofitting Sprinkler Systems for Suppressing Dust Generated by Moving Vehicles Inside Farms. *Agricultural Sciences in China* 10(3), 376-383.
8. Hočevar, M., Širok, B., Jejčič, V., Godeša, T., Lešnika, M., Stajniko, D., 2016. Design and testing of an automated system for targeted spraying in orchards. *Journal of Plant Diseases and Protection* 117(2), 71-79.
9. Zhang, Z., McHugh, A.D., Li, H., Ma, S., Wang, Q., He, J., Zheng, K., 2017. Global Overview of Research and Development of Crop Residue Management Machinery. *Appl Eng Agric* 33(3), 329-344.
10. Lion, S., Michos, C.N., Vlaskos, I., Rouaud, C., Taccani, R., 2017. A review of waste heat recovery and Organic Rankine Cycles (ORC) in on-off highway vehicle Heavy Duty Diesel Engine applications. *Renewable Sustainable Energy Rev* 79, 691-708.
11. Ruyschaert, G., Poesen, J., Notebaert, B., Verstraeten, G., Govers, G., 2008. Spatial and long-term variability of soil loss due to crop harvesting and the importance relative to water erosion: A case study from Belgium. *Agriculture, Ecosystems & Environment* 126(3-4), 217-228.
12. Kim, H.J., Sudduth, K.A., Hummel, J.W., 2009. Soil macronutrient sensing for precision agriculture. *J Environ Monit* 11(10), 1810-1824.
13. Webb, J., Pain, B., Bittman, S., Morgan, J., 2010. The impacts of manure application methods on emissions of ammonia, nitrous oxide and on crop response—A review. *Agriculture, Ecosystems & Environment* 137(1-2), 39-46.
14. Tenu, I., Jitareanu, G., Muraru-Ionel, C., Cojocariu, P., Muraru, V.M., 2009. The Impact of Mechanization Technologies on Soil. *Environ. Eng. Manag. J.* 8(5), 1263-1267.
15. Loghin, F., Capatina, I., 2010. Aspects Regarding the Reduction of Penetration Resistance of Soil as a Consequence Soil Working. *Environ. Eng. Manag. J.* 9(12), 1619-1622.
16. Bratucu, G., Paunescu, C., 2010. Research on Soil Properties Conservation during the Preparation of Germination Beds in Greenhouses. *Environ. Eng. Manag. J.* 9(12), 1693-1697.
17. Zhou, D., Lin, Z., Liu, L., 2012. Regional land salinization assessment and simulation through cellular automaton-Markov modeling and spatial pattern analysis. *Sci Total Environ* 439, 260-274.
18. Bhattacharyya, R., Ghosh, B., Mishra, P., Mandal, B., Rao, C., Sarkar, D., Das, K., Anil, K., Lalitha, M., Hati, K., Franzluebbers, A., 2015. Soil Degradation in India: Challenges and Potential Solutions. *Sustainability* 7(4), 3528-3570.

19. Eshel, G., Egozi, R., Goldwasser, Y., Kashti, Y., Fine, P., Hayut, E., Kazukro, H., Rubin, B., Dar, Z., Keisar, O., DiSegni, D.M., 2015. Benefits of growing potatoes under cover crops in a Mediterranean climate. *Agriculture, Ecosystems & Environment* 211, 1-9.
20. De Antoni Migliorati, M., Parton, W.J., Del Grosso, S.J., Grace, P.R., Bell, M.J., Strazzabosco, A., Rowlings, D.W., Scheer, C., Harch, G., 2015. Legumes or nitrification inhibitors to reduce N₂O emissions from subtropical cereal cropping systems in Oxisols? *Agriculture, Ecosystems & Environment* 213, 228-240.
21. Mousavi-Avval, S.H., Rafiee, S., Sharifi, M., Hosseinpour, S., Notarnicola, B., Tassielli, G., Renzulli, P.A., Khanali, M., 2017. Use of LCA indicators to assess Iranian rapeseed production systems with different residue management practices. *Ecol Indic* 80, 31-39.
22. Catania, P., Badalucco, L., Laudicina, V.A., Vallone, M., 2018. Effects of tilling methods on soil penetration resistance, organic carbon and water stable aggregates in a vineyard of semiarid Mediterranean environment. *Environ. Earth Sci.* 77(9).
23. Kuhwald, M., Dörnhöfer, K., Oppelt, N., Duttmann, R., 2018. Spatially Explicit Soil Compaction Risk Assessment of Arable Soils at Regional Scale: The SaSciA-Model. *Sustainability* 10(5).
24. Ke, J., He, R., Hou, P., Ding, C., Ding, Y., Wang, S., Liu, Z., Tang, S., Ding, C., Chen, L., Li, G., 2018. Combined controlled-released nitrogen fertilizers and deep placement effects of N leaching, rice yield and N recovery in machine-transplanted rice. *Agriculture, Ecosystems & Environment* 265, 402-412.
25. Bagagiolo, G., Biddoccu, M., Rabino, D., Cavallo, E., 2018. Effects of rows arrangement, soil management, and rainfall characteristics on water and soil losses in Italian sloping vineyards. *Environ Res* 166, 690-704.
26. Janulevičius, A., Čiplienė, A., 2018. Estimation of engine CO₂ and NO_x emissions and their correlation with the not-to-exceed zone for a tractor ploughing fields of various sizes. *Journal of Cleaner Production* 198, 1583-1592.
27. Jourgholami, M., Khajavi, S., Labelle, E.R., 2018. Mulching and water diversion structures on skid trails: Response of soil physical properties six years after harvesting. *Ecol. Eng.* 123, 1-9.
28. Bennett, J.M., Roberton, S.D., Marchuk, S., Woodhouse, N.P., Antille, D.L., Jensen, T.A., Keller, T., 2019. The soil structural cost of traffic from heavy machinery in Vertisols. *Soil Tillage Res.* 185, 85-93.
29. Bennett, J.M., Roberton, S.D., Marchuk, S., Woodhouse, N.P., Antille, D.L., Jensen, T.A., Keller, T., 2019. The soil structural cost of traffic from heavy machinery in Vertisols. *Soil Tillage Res.* 185, 85-93.
30. Seflek, A.Y., Marakoglu, T., Carman, K., 2017. The effects different tillage treatments on soil surface conditions and dust concentration in semi-arid Central Anatolia. *Fresenius Environmental Bulletin* 26(2 A), 1720-1726.
31. Tenu, I., Jitareanu, G., Muraru-Ionel, C., Cojocariu, P., Muraru, V.M., 2009. The Impact of Mechanization Technologies on Soil. *Environ. Eng. Manag. J.* 8(5), 1263-1267.
32. Lal, R., 2009. The Plow and Agricultural Sustainability. *Journal of Sustainable Agriculture* 33(1), 66-84.
33. Yao-Kouame, A., Yoro, G., 1991. Mechanized agriculture and soil compaction in Côte d'Ivoire. *Soil Tillage Res.* 19(2-3), 263-274.
34. Bortolini, M., Cascini, A., Gamberi, M., Mora, C., Regattieri, A., 2014. Sustainable design and life cycle assessment of an innovative multi-functional haymaking agricultural machinery. *Journal of Cleaner Production* 82, 23-36.
35. Alves, C., Ferrão, P.M.C., Freitas, M., Silva, A.J., Luz, S.M., Alves, D.E., 2009. Sustainable design procedure: The role of composite materials to combine mechanical and environmental features for agricultural machines. *Materials & Design* 30(10), 4060-4068.
36. Yang, L., Wei, W., Chen, L., Mo, B., 2012. Response of deep soil moisture to land use and afforestation in the semi-arid Loess Plateau, China. *J. Hydrol.* 475, 111-122.

37. Vasudevan, P., Philip Davies, D.J.N.P.D., Sen, P.K., Singh, S.N., Singh, P., Davies, P., Kumar Dey, P., Berry, R., 2013. Trigeneration using biomass energy for sustainable development. *Int. J. Energy Sect. Manage.* 7(3), 309-320.
38. Yang, Y.H., Yan, B.X., Zhu, H., Wang, L.X., 2011. Effects of Water and Soil Conservation Practices on Reducing Pollution from Agricultural Nonpoint Source in Northeast China. *Advanced Materials Research* 356-360, 2473-2478.
39. Baumhardt, R.L., Johnson, G.L., Schwartz, R.C., 2012. Residue and Long-Term Tillage and Crop Rotation Effects on Simulated Rain Infiltration and Sediment Transport. *Soil Sci. Soc. Am. J.* 76(4), 1370-1378.
40. Guimarães, R.M.L., Ball, B.C., Tormena, C.A., Giarola, N.F.B., da Silva, Á.P., 2013. Relating visual evaluation of soil structure to other physical properties in soils of contrasting texture and management. *Soil Tillage Res.* 127, 92-99.
41. López-Garrido, R., Deurer, M., Madejón, E., Murillo, J.M., Moreno, F., 2012. Tillage influence on biophysical soil properties: The example of a long-term tillage experiment under Mediterranean rainfed conditions in South Spain. *Soil Tillage Res.* 118, 52-60.
42. Ozturkmen, A.R., Kavdir, Y., 2012. Comparison of some quality properties of soils around land-mined areas and adjacent agricultural fields. *Environ Monit Assess* 184(3), 1633-1643.
43. Aulakh, M.S., Manchanda, J.S., Garg, A.K., Kumar, S., Dercon, G., Nguyen, M.-L., 2012. Crop production and nutrient use efficiency of conservation agriculture for soybean-wheat rotation in the Indo-Gangetic Plains of Northwestern India. *Soil Tillage Res.* 120, 50-60.
44. Van Wie, J.B., Adam, J.C., Ullman, J.L., 2013. Conservation tillage in dryland agriculture impacts watershed hydrology. *J. Hydrol.* 483, 26-38.
45. Wyngaard, N., Echeverría, H.E., Rozas, H.R.S., Divito, G.A., 2012. Fertilization and tillage effects on soil properties and maize yield in a Southern Pampas Argiudoll. *Soil Tillage Res.* 119, 22-30.
46. Hassan-Esfahani, L., Torres-Rua, A., McKee, M., 2015. Assessment of optimal irrigation water allocation for pressurized irrigation system using water balance approach, learning machines, and remotely sensed data. *Agric. Water Manage.* 153, 42-50.
47. Huggins, D.R., Kruger, C.E., Painter, K.M., Uberuaga, D.P., 2014. Site-Specific Trade-offs of Harvesting Cereal Residues as Biofuel Feedstocks in Dryland Annual Cropping Systems of the Pacific Northwest, USA. *Bioenergy Res.* 7(2), 598-608.
48. Villamil, M.B., Little, J., Nafziger, E.D., 2015. Corn residue, tillage, and nitrogen rate effects on soil properties. *Soil Tillage Res.* 151, 61-66.
49. Thierfelder, C., Matemba-Mutasa, R., Rusinamhodzi, L., 2015. Yield response of maize (*Zea mays* L.) to conservation agriculture cropping system in Southern Africa. *Soil Tillage Res.* 146, 230-242.
50. Saljnikov, E., Saljnikov, A., Rahimgalieva, S., Cakmak, D., Kresovic, M., Mrvic, V., Dzhalkankuzov, T., 2014. Impact of energy saving cultivations on soil parameters in northern Kazakhstan. *Energy* 77, 35-41.
51. Dal Ferro, N., Sartori, L., Simonetti, G., Berti, A., Morari, F., 2014. Soil macro- and microstructure as affected by different tillage systems and their effects on maize root growth. *Soil Tillage Res.* 140, 55-65.
52. Abdollahi, L., Munkholm, L.J., 2014. Tillage System and Cover Crop Effects on Soil Quality: I. Chemical, Mechanical, and Biological Properties. *Soil Sci. Soc. Am. J.* 78(1), 262-270.
53. Hurisso, T.T., Norton, J.B., Norton, U., 2014. Labile soil organic carbon and nitrogen within a gradient of dryland agricultural land-use intensity in Wyoming, USA. *Geoderma* 226-227, 1-7.
54. Kuotsu, K., Das, A., Lal, R., Munda, G.C., Ghosh, P.K., Ngachan, S.V., 2014. Land forming and tillage effects on soil properties and productivity of rainfed groundnut (*Arachis hypogaea* L.)-rapeseed (*Brassica campestris* L.) cropping system in northeastern India. *Soil Tillage Res.* 142, 15-24.
55. T., J., L.J., M., O., G., H., K., 2015. Soil Surface Roughness Using Cumulated Gaussian Curvature.
56. Jensen, T., Munkholm, L.J., Green, O., Karstoft, H., 2015. Soil Surface Roughness Using Cumulated Gaussian Curvature. Springer International Publishing, Cham, pp. 533-541.

57. Mendez, I., Doyle, P., Sims, B., Twomlow, S., 1997. Participatory development of an animal-drawn tied-ridger in Mexico. *Int Agric Eng J* 6(2), 61-74.
58. Yang, Q., Yang, C., 2010. Conservation Tillage Methods and Key Techniques for Two-crop Annual Rotation in Semi-arid Regions in North China, 2010 Pittsburgh, Pennsylvania, June 20-June 23, 2010. American Society of Agricultural and Biological Engineers, p. 1.
59. Yin, H., Zhang, E., Wang, Q., Liu, Q., Liu, C., Wang, T., Yu, H., 2011. Effect of spring wheat stubble treatments on grain yield and water use efficiency of multiple cropping rape. *Transactions of the Chinese Society of Agricultural Engineering* 27(2), 83-88.
60. Zheng, H., Zheng, J., Luo, Y., Li, R., Li, W., Wang, H., Ren, H., Qi, H., Liu, W., 2015. Change characteristic of soil compaction of long-term different tillage methods in cropland. *Transactions of the Chinese Society of Agricultural Engineering* 31(9), 63-70.
61. Congreves, K.A., Hayes, A., Verhallen, E.A., Van Eerd, L.L., 2015. Long-term impact of tillage and crop rotation on soil health at four temperate agroecosystems. *Soil Tillage Res.* 152, 17-28.
62. Sharma, P., Singh, G., Sarkar, S.K., Singh, R.P., 2015. Improving soil microbiology under rice-wheat crop rotation in Indo-Gangetic Plains by optimized resource management. *Environ Monit Assess* 187(3), 150.
63. Ingrao, C., Matarazzo, A., Tricase, C., Clasadonte, M.T., Huisinigh, D., 2015. Life Cycle Assessment for highlighting environmental hotspots in Sicilian peach production systems. *Journal of Cleaner Production* 92, 109-120.
64. Holub, S.M., Terry, T.A., Harrington, C.A., Harrison, R.B., Meade, R., 2013. Tree growth ten years after residual biomass removal, soil compaction, tillage, and competing vegetation control in a highly-productive Douglas-fir plantation. *For. Ecol. Manage.* 305, 60-66.
65. Locke, M.A., Krutz, L.J., Steinriede, R.W., Testa, S., 2015. Conservation Management Improves Runoff Water Quality: Implications for Environmental Sustainability in a Glyphosate-Resistant Cotton Production System. *Soil Sci. Soc. Am. J.* 79(2), 660-671.
66. Singh, A., Phogat, V.K., Dahiya, R., Batra, S.D., 2014. Impact of long-term zero till wheat on soil physical properties and wheat productivity under rice-wheat cropping system. *Soil Tillage Res.* 140, 98-105.
67. Liu, E., Tecler, S.G., Yan, C., Yu, J., Gu, R., Liu, S., He, W., Liu, Q., 2014. Long-term effects of no-tillage management practice on soil organic carbon and its fractions in the northern China. *Geoderma* 213, 379-384.
68. Garofalo, P., D'Andrea, L., Vonella, A.V., Rinaldi, M., Palumbo, A.D., 2015. Energy performance and efficiency of two sugar crops for the biofuel supply chain. Perspectives for sustainable field management in southern Italy. *Energy* 93, 1548-1557.
69. Wei, K., Chen, Z., Zhu, A., Zhang, J., Chen, L., 2014. Application of ³¹P NMR spectroscopy in determining phosphatase activities and P composition in soil aggregates influenced by tillage and residue management practices. *Soil Tillage Res.* 138, 35-43.
70. Abdullah, A.S., 2014. Minimum tillage and residue management increase soil water content, soil organic matter and canola seed yield and seed oil content in the semiarid areas of Northern Iraq. *Soil Tillage Res.* 144, 150-155.
71. Sun, Y., Zeng, Y., Shi, Q., Pan, X., Huang, S., 2015. No-tillage controls on runoff: A meta-analysis. *Soil Tillage Res.* 153, 1-6.
72. Robert, K., Elisabeth, Q., Josef, B., 2015. Analysis of occupational accidents with agricultural machinery in the period 2008–2010 in Austria. *Saf. Sci.* 72, 319-328.
73. Abdollahi, L., Hansen, E.M., Rickson, R.J., Munkholm, L.J., 2015. Overall assessment of soil quality on humid sandy loams: Effects of location, rotation and tillage. *Soil Tillage Res.* 145, 29-36.
74. Bhaduri, D., Purakayastha, T.J., Patra, A.K., Chakraborty, D., 2014. Evaluating soil quality under a long-term integrated tillage-water-nutrient experiment with intensive rice-wheat rotation in a semi-arid Inceptisol, India. *Environ Monit Assess* 186(4), 2535-2547.
75. Mukherjee, A., Lal, R., 2015. Tillage effects on quality of organic and mineral soils under on-farm conditions in Ohio. *Environ. Earth Sci.* 74(2), 1815-1822.

76. Balota, E.L., Yada, I.F., Amaral, H., Nakatani, A.S., Dick, R.P., Coyne, M.S., 2014. Long-Term Land Use Influences Soil Microbial Biomass P and S, Phosphatase and Arylsulfatase Activities, and S Mineralization in a Brazilian Oxisol. *Land Degradation & Development* 25(4), 397-406.
77. Smith, S.F., Brye, K.R., Gbur, E.E., Chen, P., Korth, K., 2014. Residue and Water Management Effects on Aggregate Stability and Aggregate-Associated Carbon and Nitrogen in a Wheat-Soybean, Double-Crop System. *Soil Sci. Soc. Am. J.* 78(4), 1378-1391.
78. Calegari, A., Tiecher, T., Hargrove, W.L., Ralisch, R., Tessier, D., de Tourdonnet, S., Guimarães, M.d.F., dos Santos, D.R., 2013. Long-term effect of different soil management systems and winter crops on soil acidity and vertical distribution of nutrients in a Brazilian Oxisol. *Soil Tillage Res.* 133, 32-39.
79. Houshyar, E., SheikhDavoodi, M.J., Almassi, M., Bahrami, H., Azadi, H., Omid, M., Sayyad, G., Witlox, F., 2014. Silage corn production in conventional and conservation tillage systems. Part I: Sustainability analysis using combination of GIS/AHP and multi-fuzzy modeling. *Ecol Indic* 39, 102-114.
80. Sime, G., Aune, J.B., Mohammed, H., 2015. Agronomic and economic response of tillage and water conservation management in maize, central rift valley in Ethiopia. *Soil Tillage Res.* 148, 20-30.
81. de Oliveira Bordonal, R., Barretto de Figueiredo, E., Aguiar, D.A., Adami, M., Theodor Rudorff, B.F., La Scala, N., 2013. Greenhouse gas mitigation potential from green harvested sugarcane scenarios in São Paulo State, Brazil. *Biomass Bioenergy* 59, 195-207.
82. Franzluebbers, A.J., Stuedemann, J.A., 2014. Temporal Dynamics of Total and Particulate Organic Carbon and Nitrogen in Cover Crop Grazed Cropping Systems. *Soil Sci. Soc. Am. J.* 78(4), 1404-1413.
83. Paré, M.C., Lafond, J., Pageau, D., 2015. Best management practices in Northern agriculture: A twelve-year rotation and soil tillage study in Saguenay–Lac-Saint-Jean. *Soil Tillage Res.* 150, 83-92.
84. Abdollahi, L., Getahun, G.T., Munkholm, L.J., 2017. Eleven Years' Effect of Conservation Practices for Temperate Sandy Loams: I. Soil Physical Properties and Topsoil Carbon Content. *Soil Sci. Soc. Am. J.* 81(2), 380-391.
85. Zhang, Q., Liu, D., Cheng, S., Huang, X., 2016. Combined effects of runoff and soil erodibility on available nitrogen losses from sloping farmland affected by agricultural practices. *Agric. Water Manage.* 176, 1-8.
86. Nunes, F.A., Seferin, M., Maciel, V.G., Flôres, S.H., Ayub, M.A.Z., 2016. Life cycle greenhouse gas emissions from rice production systems in Brazil: A comparison between minimal tillage and organic farming. *Journal of Cleaner Production* 139, 799-809.
87. Zhang, S., Chen, X., Jia, S., Liang, A., Zhang, X., Yang, X., Wei, S., Sun, B., Huang, D., Zhou, G., 2015. The potential mechanism of long-term conservation tillage effects on maize yield in the black soil of Northeast China. *Soil Tillage Res.* 154, 84-90.
88. Wang, L., Dalabay, N., Lu, P., Wu, F., 2017. Effects of tillage practices and slope on runoff and erosion of soil from the Loess Plateau, China, subjected to simulated rainfall. *Soil Tillage Res.* 166, 147-156.
89. Zhang, G.S., Ni, Z.W., 2017. Winter tillage impacts on soil organic carbon, aggregation and CO₂ emission in a rainfed vegetable cropping system of the mid-Yunnan plateau, China. *Soil Tillage Res.* 165, 294-301.
90. Kabiri, V., Raiesi, F., Ghazavi, M.A., 2015. Six years of different tillage systems affected aggregate-associated SOM in a semi-arid loam soil from Central Iran. *Soil Tillage Res.* 154, 114-125.
91. Zhang, Z., Qiang, H., McHugh, A.D., He, J., Li, H., Wang, Q., Lu, Z., 2016. Effect of conservation farming practices on soil organic matter and stratification in a mono-cropping system of Northern China. *Soil Tillage Res.* 156, 173-181.
92. Lopez-Bellido, R.J., Muñoz-Romero, V., Fuentes-Guerra, R., Fernandez-Garcia, P., Lopez-Bellido, L., 2017. No-till: A key tool for sequestering C and N in microaggregates on a Mediterranean Vertisol. *Soil Tillage Res.* 166, 131-137.

93. Valboa, G., Lagomarsino, A., Brandi, G., Agnelli, A.E., Simoncini, S., Papini, R., Vignozzi, N., Pellegrini, S., 2015. Long-term variations in soil organic matter under different tillage intensities. *Soil Tillage Res.* 154, 126-135.
94. Kinoshita, R., Schindelbeck, R.R., van Es, H.M., 2017. Quantitative soil profile-scale assessment of the sustainability of long-term maize residue and tillage management. *Soil Tillage Res.* 174, 34-44.
95. Pi, H., Sharratt, B., 2017. Evaluation of the RWEQ and SWEEP in simulating soil and PM10 loss from a portable wind tunnel. *Soil Tillage Res.* 170, 94-103.
96. Rodrigo Comino, J., Senciales, J.M., Ramos, M.C., Martínez-Casasnovas, J.A., Lasanta, T., Brevik, E.C., Ries, J.B., Ruiz Sinoga, J.D., 2017. Understanding soil erosion processes in Mediterranean sloping vineyards (Montes de Málaga, Spain). *Geoderma* 296, 47-59.
97. Kühling, I., Redozubov, D., Broll, G., Trautz, D., 2017. Impact of tillage, seeding rate and seeding depth on soil moisture and dryland spring wheat yield in Western Siberia. *Soil Tillage Res.* 170, 43-52.
98. Zhang, H., Zhang, Y., Yan, C., Liu, E., Chen, B., 2016. Soil nitrogen and its fractions between long-term conventional and no-tillage systems with straw retention in dryland farming in northern China. *Geoderma* 269, 138-144.
99. Pal, P.K., Mahajan, M., 2017. Tillage system and organic mulch influence leaf biomass, steviol glycoside yield and soil health under sub-temperate conditions. *Ind. Crop. Prod.* 104, 33-44.
100. Barsotti, J.L., Sainju, U.M., Lenssen, A.W., Montagne, C., Hatfield, P.G., 2013. Crop yields and soil organic matter responses to sheep grazing in US northern Great Plains. *Soil Tillage Res.* 134, 133-141.
101. Chávez-Romero, Y., Navarro-Noya, Y.E., Reynoso-Martínez, S.C., Sarria-Guzmán, Y., Govaerts, B., Verhulst, N., Dendooven, L., Luna-Guido, M., 2016. 16S metagenomics reveals changes in the soil bacterial community driven by soil organic C, N-fertilizer and tillage-crop residue management. *Soil Tillage Res.* 159, 1-8.
102. Singh, V.K., Yadvinder, S., Dwivedi, B.S., Singh, S.K., Majumdar, K., Jat, M.L., Mishra, R.P., Rani, M., 2016. Soil physical properties, yield trends and economics after five years of conservation agriculture based rice-maize system in north-western India. *Soil Tillage Res.* 155, 133-148.
103. Okeyo, J.M., Norton, J., Koala, S., Waswa, B., Kihara, J., Bationo, A., 2016. Impact of reduced tillage and crop residue management on soil properties and crop yields in a long-term trial in western Kenya. *Soil Res.* 54(6).
104. Tuzzin de Moraes, M., Debiassi, H., Carlesso, R., Cezar Franchini, J., Rodrigues da Silva, V., Bonini da Luz, F., 2016. Soil physical quality on tillage and cropping systems after two decades in the subtropical region of Brazil. *Soil Tillage Res.* 155, 351-362.
105. Laufer, D., Loibl, B., Märlander, B., Koch, H.-J., 2016. Soil erosion and surface runoff under strip tillage for sugar beet (*Beta vulgaris* L.) in Central Europe. *Soil Tillage Res.* 162, 1-7.
106. Garcia-Marco, S., Abalos, D., Espejo, R., Vallejo, A., Mariscal-Sancho, I., 2016. No tillage and liming reduce greenhouse gas emissions from poorly drained agricultural soils in Mediterranean regions. *Sci Total Environ* 566-567, 512-520.
107. Ma, Z., Chen, J., Lyu, X., Liu, L.-l., Siddique, K.H.M., 2016. Distribution of soil carbon and grain yield of spring wheat under a permanent raised bed planting system in an arid area of northwest China. *Soil Tillage Res.* 163, 274-281.
108. Goya, W.A., Andrade, M.R.D., Zucchi, A.C., Gonzalez, N.M., Pereira, R.D.F., Langona, K., Carvalho, T.C.M.D.B., Mângs, J.-E., Sefidcon, A., 2014. The use of distributed processing and cloud computing in agricultural decision-making support systems, 2014 IEEE 7th International Conference on Cloud Computing. Anchorage, AK, USA, pp. 721-728.
109. Zhang, Y., Du, R., Diao, P., Geng, D., 2015. Mechanical and ecological tillage pattern improving soil quality and crop yields. *Transactions of the Chinese Society of Agricultural Engineering* 31(7), 33-38.

110. Li, L., Wang, G., Liang, F., Wang, D., Liu, L., Wang, Z., Zhang, X., Guo, L., Li, T., 2015. The design of grassland soil-gashing and root-cutting machine with profiling mechanism, 2015 ASABE Annual International Meeting. American Society of Agricultural and Biological Engineers, p. 1.
111. Zhang, T., Liu, F., Zhao, M., Liu, Y., Li, F., Chen, C., Zhang, Y., 2016. Movement law of maize population in seed room of seed metering device based on discrete element method. Transactions of the Chinese Society of Agricultural Engineering 32(22), 27-35.
112. Haijin, Z., Jie, Y., Pengfei, H., 2016. Effects of straw mulching and vetiver grass hedgerows on peanut growth and soil property in red soil sloping field. Transactions of the Chinese Society for Agricultural Machinery 47(4), 119-126.
113. Zeng, J., Shao, J.a., Xie, D., 2016. Dynamic changes of soil organic carbon for basic farmland and nonbasic farmland of Dianjiang county in recent 30 years. Transactions of the Chinese Society of Agricultural Engineering 32(13), 254-262. (Thornhill et al., 2017)



Appendix 7

Initial categorization of the economic and social dimension's critical features, diagnostic criteria and rapid sustainability assessment indicators

Table A7. 1. Initial categorization of the economic dimension's critical features, diagnostic criteria and rapid sustainability assessment indicators from agriculture domain.

Category	Critical Features	Diagnostic Criteria	Sub-diagnostic Criteria	Rapid Sustainability Assessment Indicator	
PSS providers' investment	Internal investment	Impact on social, economic, environmental and governance performance	-	Allocation and use of resources like time, human resources, and funds of the enterprise for monitoring and improving its sustainability performance.	
		Impact on long term profitability	-	Investment on research on product development, training programs for selected employees, acquisition of resources (e.g., land or businesses, equipment and facilities), the design and implementation of a marketing strategy, etc.	
	Community investment	Impact on community	-	Enterprises' investment has contributed to meet community (affected stakeholders) needs (social, economic, cultural, technical, environmental, organizational, or others)	
PSS providers' organizational characteristics	Business plan	Effectiveness of Business Plan	Marketing Strategy	Whether the enterprise has a business plan or an up-to-date document articulating revenue streams, growth plan, and an operational action plan that projects the generation of financial resources for the future. Objectives to achieve and the strategy to implement.	
			Financial Strategy		
			Investment Strategy		
			Product Strategy		
	Competitiveness	Business development	-	Business Development - access to market information, price transparency, reference to similarly priced products, quality awareness, record keeping, business sustainability	
			Differentiation	-	Differentiation - in practices for product/ output quality, compliance/ availability of certification/ standards, price premium possibility
			Efficiency	-	Efficiency - technical, cost, resource efficiency
	Governance	Customers' perception	-	Customers' perception of the PSS providers.	
		Customers' participation	-	Customers' participation in the PSS design/ development/ management/ other processes.	
	Services	Availability of services	Financial	Collaborations/ processes that ease the process of securing financial services for availing the PSS.	
Training			Collaborations/ processes that take care of training needs for availing the PSS.		
Repair/ Maintenance			Collaborations/ processes that take care of repair/ maintenance needs for availing the PSS.		
Risk management	Risk (economic resilience)	Diversification	Revenue from other crops than the focus crop, revenue from other sources like renting, training, whether the enterprise produces more than one product, or variety of plant or animal for income generation, or offers more than one service.		

			Information	Access to market information, price transparency (understanding of the factors that affect the price they receive for focus crop (quality, consistency, variety, etc.))
			Credit	Access to credit, credit history
			Vulnerability	Poverty status, income made using this method vs. minimum wage, insurance, days of use, gender differences, profit and loss
		Risk management	-	Whether the enterprise has put in place a plan to reduce and adapt itself against risks that could potentially threaten the business. Some risks the enterprise could be exposed to include price, production, market and credit risk, unstable employment relations, unavailability of workforce, conflicts with the community and other stakeholders, natural disasters, diseases and climate change. internal risks are those that the enterprise can have more control on within the scope of the business (e.g., accidents at the workplace). External risks are those risks that the enterprise does not have any control on (e.g., heavy rains).
Customer	Livelihoods	Revenue	-	Yield, Price, Revenue
		Costs	-	Costs - direct, indirect, labor, input (fertilizer/ pesticide/ water/ fuel/etc.), recurring, maintenance, depreciation, energy, capital assets, cultivation practices change cost, traceability & record keeping, costs of standard/ certification, cost of allied activities required (input, labor, waste disposal), training cost
		Net income	-	Net income
		Transparency	-	Information on costs (fixed, recurring, maintenance, etc.), alternatives, income and savings potential, possible health/ safety hazards, resale/ end-of-life value.
	Perception	Economic situation	-	How do the customers perceive the economic situation?
		Price	-	Do the customers perceive the price as reasonable/ value for money/ affordable?
		Transparency	-	Do the customers perceive that the PSS providers and the value chain as transparent?
		Income	-	Do the customers perceive that the PSS will improve their income?
		Risk	-	Do the customers perceive that the PSS will reduce their risks?
		Costs	-	Do the customers perceive that the PSS will reduce their costs?
Competitiveness	Quality	-	Do the customers perceive that the PSS will improve the quality of their output?	
	Competitiveness	-	Will the PSS improve the competitiveness of the customer in their offering?	
Finances	Net income	Net income	-	Whether the total revenue earned by the enterprise in the last five years associated with producing the goods and services sold by the enterprise exceeds the total expenses, including interests and taxes
	Cost of Production	Cost of Production	-	Measures whether the enterprise has completed a process to determine the total cost of the products sold and per unit of production using currency and has calculated the break-even point.
	Price determination	Price determination	-	Measures whether the enterprise has considered the break-even point to negotiate the selling price with the buyer(s), using currency.

	Net cash flow	Net cash flow	-	Net cash flow generated by the enterprise
	Safety nets	Safety nets	-	Whether the enterprise has access to formal and informal financial sources to withstand liquidity crises. Formal safety nets are those which legally guarantee the enterprise access to financial, economic or social support (i.e. banks, micro-credit institutions, public social programs, government transfers of food or cash). Informal safety nets provide likelihood of support to the enterprise to cope with the risk and vulnerable situation is facing, but with no legal guarantee (i.e. family, friends, community groups and non-governmental institutions).
	Economic stability	Net debt service over change in owner's equity & interest paid	-	Cash flow/raw performance rate
		Equity ratio	-	Dynamic gearing
		Gross investment	-	Condition of machines, buildings & perennial crops
	Economic efficiency	Return on assets	-	Measure productivity
		Return on equity	-	
		Total earned income	-	
	Fiscal commitment	Fiscal commitment	-	whether the enterprise pays the taxes as indicated by local regulations that are applicable to its business in all countries of its operation.
Local economy	Local workforce	Share of regional workforce & salaries	-	Raw performance per unit agricultural land
		Lowest salary on farm compared to average regional salary	-	
	Local procurement	Local procurement	-	Whether the enterprise has purchased its inputs/ingredients/products from local suppliers when equal or similar conditions exist, in comparison to non-local suppliers
Market conditions	Supplier power	Guarantee of Production Levels	-	Measures whether the enterprise has access to, and implements mechanisms to, prevent any disruption of the volume of production and/or quality standards.
		Stability of Supplier Relationships	-	Measures the share of supplier contracts/business relationship that has remained ongoing
		Dependence on the Leading Supplier	-	Measures the share of the input supplies that come from the leading supplier
		Procurement channels	-	Measures the extent to which the enterprise has implemented actions and mechanisms to ensure stable supply and reduce the risk to have input supply shortages. This includes maintaining on-going business relationships with suppliers.

	Market stability		-	<p>Measures the extent to which the enterprise has guaranteed its stability in the market through the implementation of actions and mechanisms to ensure a diversified and consolidated income structure from the product sales, making contact with potential buyers, negotiating price and conditions, contracting and transferring the products and goods.</p> <p>The ultimate goal of the marketing channels is to guarantee that the products or goods are sold at an appropriate time, and the enterprise earns revenue.</p> <p>The enterprise requires designing and implementing a marketing strategy to identify potential buyers that could meet the enterprise expectations and could eventually purchase its products and goods.</p> <p>Market risk could be significantly reduced through the establishment of stable business relationships with a diversified number of buyers.</p> <p>Market risk could be minimized through the identification of alternative marketing channels that could be accessible when contracts, agreements or relationships are discontinued.</p> <p>In post-harvest chains of perishable products, additional uncertainties have to be considered because of vulnerabilities in market supply and prices influenced by a number of factors, such as climate-related diseases or other natural disasters and costumers' behavior.</p>
	Competitiveness		-	What is the competition in the market like?
	Local vs global	Material procurement	-	Is the procurement local/ global? What are the challenges, limitations and uncertainties due to that?
		Labor	-	Is adequately trained workforce available?
Product characteristics	Diversification	Diversification	-	Extent to which the product offerings are diversified?
	Quality	Certification/ standards	-	Is the product certified? Does the product follow specific standards? Can the product be taken for certifications/ made to meet standards?
		Quality of output	-	What is the quality of the output due to the product?
		Competitive quality	-	Does the product give a competitive quality advantage for the output?
	Use versatility		-	Is the product multi-purpose?
	Control measures		-	whether the enterprise has food hazards and safety control measures in place that comply with correspondent regulations
	Hazardous pesticides		-	Whether any of the enterprise' employees have handled, stored or used any highly hazardous and other pesticides during the last five years, as well the use of biological or mechanical pest management techniques.
Food contamination		-	Whether there are any documented incidents at the enterprise where pesticides residues in ingredients or products have exceeded the maximum allowed limits during the last 5 years. it also measures whether there are any documented incidents of chemical and biological food contamination (i.e., due to the use of heavy metals, unapproved GMOs, mycotoxins) during the last five years.	

Food quality	-	Measures the share of the total volume of production that meets quality standards, that is the set of parameters describing internal (e.g., taste, maturity, nutritional content) and external (e.g. cleanliness, color freshness, shape, presentation, packing) characteristics, which are necessary to ensure safety, transparency in trade and good eating quality
System traceability	-	The share of the volume of production that can be identified and recalled along the food chain and in the marketplace through a traceability system, at least in the last production year.
Certified production	-	Certified or not
Product labelling	-	Mandatory labeling as required in the country of sale

Table A7. 2. Initial categorization of the social dimension's critical features, diagnostic criteria, and rapid sustainability assessment indicators from agriculture domain.

Category	Critical Features	Diagnostic Criteria	Sub-diagnostic Criteria	Rapid Sustainability Assessment Indicator
Livelihood	Decent livelihood	Quality of life	Working conditions	<p>Do the workers/ employees have</p> <ul style="list-style-type: none"> • healthy work hours? • No compulsory overtimes? <ul style="list-style-type: none"> • Voluntary overtime with extra compensation at a higher rate and additional rest days when the overload period (like harvesting) is over? • Regular breaks for needs like sanitation, meals, etc.? • Adequate breaks and rests during peak work times also? <ul style="list-style-type: none"> • Ability to participate in their cultural activities, speak the language, and practice the religion of their choice (time and space included), freedom of expression? • Ability to enjoy a diet of choice, have time to procure, produce, and prepare meals, have a healthy nutritional diet for themselves and their family? • Leisure time, family time, have a good quality of life?
			Wage levels	Are employees/ workers/ owners being paid or making a living wage that can cover the cost of a nutritious diet, basic acceptable housing, cost of clothing and footwear, and other costs required for a decent life?
		Capacity development	-	<ul style="list-style-type: none"> • Do employees have opportunities for: <ul style="list-style-type: none"> - Capacity development? - Advancement within the enterprise? • Do the producers have the possibility to adopt improved techniques to make the enterprise more productive, efficient, environment-friendly, innovative, profitable. • Is future generation/ management identified, motivated, trained, and prepared?

Category	Critical Features	Diagnostic Criteria	Sub-diagnostic Criteria	Rapid Sustainability Assessment Indicator	
Equity and justice	Equity and Justice	Fair access to means of production	-	Do the stakeholders have fair access to means of production: <ul style="list-style-type: none"> • agricultural extension services? • training/ conferences/ events/ courses/ other services for knowledge/ skill up-gradation? • necessary equipment and facilities like buildings, storage, transport, repair/ maintenance, spares, upgrades, quality inputs, etc.? 	
		Fair pricing	-	<ul style="list-style-type: none"> • Will it provide a living wage to employees? • Will it cover the costs? • Will it cover investments required for future growth? • Will it aid in creating savings? • Are the pricing terms mutually agreeable to involved stakeholders and laid down? 	
		Transparency	-	<ul style="list-style-type: none"> • Are business processes laid down and informed to stakeholders? • Are conflict/ grievance resolution rules laid down and known to stakeholders? • Are terms of all contracts laid down and known to stakeholders? • Are all parties involved in an agreement free to terminate the same? • Are the financial implications of entering into an agreement clearly stated? • Are the agreement clauses restrictive (e.g., limit the farmer to grow only the agreed crop, limit the supplier to supply only to the PSS provider)? Does that restrict equity and justice? 	
		Labor rights	Employment relations		<ul style="list-style-type: none"> • Are employment contracts clear to the employees? Do they mention: <ul style="list-style-type: none"> • Nature of work? • Working hours? • Rules regarding conduct, conflict/ grievance redressal, and terminations of contract? <ul style="list-style-type: none"> • Compensation pay, overtime policy, leaves?
				Forced labor	<ul style="list-style-type: none"> • Is there any form of forced labor involved?
				Child labor	<ul style="list-style-type: none"> • Is child labor involved in the value chain?
				Freedom of association and right to bargaining	<ul style="list-style-type: none"> • Do they have freedom of association and collective bargaining?
			Non-discrimination	<ul style="list-style-type: none"> • Are there discriminations based on religion, gender, age, caste, etc., in the entire value chain? 	
Gender equality	-	<ul style="list-style-type: none"> • Is gender-based discrimination (like opportunities, pay, workload, scheduling, benefits, etc.) present in the value chain? • Is the value chain designed to be gender-neutral and gender-sensitive? 			

Category	Critical Features	Diagnostic Criteria	Sub-diagnostic Criteria	Rapid Sustainability Assessment Indicator
		Support for vulnerable people	–	These may include people with different degrees of ability and disability, minorities or socially disadvantaged groups, young or aged workers. Are these groups supported and integrated or discouraged and marginalized (as workforce members or community members)? How?
Well-being	Safety and health	Training	–	<p>Are employees/ labor/ stakeholders informed and trained to</p> <ul style="list-style-type: none"> • Handle health and safety precautions while engaged with dangerous/ accident prone/ hazardous areas/ equipment/ chemicals and avoid exposure? • Use safety equipment and protective gear? • Follow ergonomically correct practices while at work?
		Safety	–	<ul style="list-style-type: none"> • Is the workplace safe and have safety measures in place? Does it have potential health hazards associated? • Are the operational stages safe and follow safety measures? Does it have potential health hazards associated? • Are the equipment and its support/ consumable products safe? Does it have potential health hazards associated? • Are dangers highlighted using signages? • Are safety equipment and protective gear made available?
		Health coverage and access to medical care	–	<ul style="list-style-type: none"> • Is health coverage being provided? • Is access to medical care available for emergency situations?
		Public health	–	<ul style="list-style-type: none"> • Does the value chain negatively impact the local community's health and well-being by polluting or contaminating water, air and soils? • Does the value chain positively impact the local community's health and well-being?
	Social Security	Availability of social security	–	<ul style="list-style-type: none"> • Is social security available to the PSS provider's employees? • Is social security available for the informal sector workers of the value chain? • Does the PSS/ the value chain have an impact on indigenous knowledge?
Empower/ valorize local resources	Cultural diversity	Indigenous knowledge	–	<ul style="list-style-type: none"> • Does the PSS/ value chain exploit indigenous knowledge without giving due knowledge meant and monetary returns to the community? • Does the PSS/ the value chain use in indigenous knowledge which in the given context might result into more sustainable practices?
		Local and sustainable food system	–	<ul style="list-style-type: none"> • Are locally adapted seed varieties, livestock breeds, traditional heirloom varieties, etc. used/ their production supported? • Does the system eliminate or reduce the use of locally adapted seed varieties, livestock breeds, traditional heirloom varieties, etc.? • Is local procurement of raw materials, manufacturing facilities, workforce, etc. supported? • Are local resources empowered/ valorized?

Category	Critical Features	Diagnostic Criteria	Sub-diagnostic Criteria	Rapid Sustainability Assessment Indicator
Empowerment through collective participation and engagement	Participation and engagement	Stakeholder identification and engagement	-	<ul style="list-style-type: none"> • Are all stakeholders who are affected by the system identified, endorsed and involved? • Who are the most vulnerable stakeholders of the system? Are they identified, endorsed and involved? • Is participatory action research and participatory design part of the PSS's operation procedure?
		Effective participation	-	<ul style="list-style-type: none"> • Is the impact of stakeholder participation measured and acknowledged? • Have the pointers from participatory action research and participatory design been incorporated into the system design and functioning? • Has the results and conclusions from the participatory action research and participatory design been communicated back to the stakeholders?
		Engagement barriers	-	<ul style="list-style-type: none"> • What are the barriers in the way of effective engagement of stakeholders? • Are strategies in place to overcome the barriers to engagement?
	Grievance	Grievance redressal	-	<ul style="list-style-type: none"> • Are grievance redressal procedures available for all stakeholders? • Are stakeholders satisfied with the procedure?
	Conflicts	Conflict resolution	-	<ul style="list-style-type: none"> • Are there conflicts of interest between stakeholders? • How are they resolved? • Are stakeholders satisfied with the resolution?
Responsible and sustainable consumption	Perception & responsibility	Quality of life	-	<ul style="list-style-type: none"> • Do stakeholders have a positive perception regarding their quality of life? • Do stakeholders give a regard to the quality of life for other stakeholders in their decision-making processes?
		Social responsibility	-	<ul style="list-style-type: none"> • Do the PSS providers and its supply chain actors value social responsibility? • Do they enact socially responsible practices?
		Care for the environment	-	<ul style="list-style-type: none"> • Do the stakeholders value care for the environment? • Do they enact environment-friendly practices?
	Community service	Community service provision	-	<ul style="list-style-type: none"> • Are community services (like building toilets/ access to clean drinking water, etc. for the local community) provided as part of corporate social responsibility activities?
	Transparency	Sustainability management plan	-	<ul style="list-style-type: none"> • Are formal sustainability management plans in place?
		Holistic audits	-	<ul style="list-style-type: none"> • Are progress towards sustainability goals measured and corrective actions taken?
Due diligence		-	<ul style="list-style-type: none"> • Do the PSS providers proactively consider their external impact while making decisions? • Are long-term impact on the environmental, economic and social sustainability considered while making decisions? 	

Appendix 8

G-SAM Evaluation strategy 1 data

The video lectures for introducing sustainability, design for sustainability, and agricultural sustainability are as follows:

- ♦ <https://www.dropbox.com/s/6x0vhto3e96ozy3/720p.MOV?dl=0>
- ♦ <https://www.dropbox.com/s/wnly73jv4cwwmiy/720p3.MOV?dl=0>

Part A of the Question

List down all the sustainability aspects that you considered or could not consider in your design. Use drawings/ photos from your sheets/ images from the internet/ etc., to explain. You can use the internet. Answer the question individually.

Part B of the Question

1. Download and print the G-SAM.pdf
2. Tick the numbered column if you think that particular diagnostic criteria are applicable for your project (using a blue pen). To determine applicability, read the columns on the left of the numbered column.
3. If you do not understand a particular column's meaning, mark it with a red pen.
4. Once you have ticked the applicable columns on all three dimensions, read the column "Rapid Sustainability Assessment Indicator" for the applicable columns.
5. Conduct an assessment using the mentioned "Rapid Sustainability Assessment Indicator."
6. At least 7 columns in each dimension should be analyzed, but you can mark more than 7 columns, as applicable, for your project.
7. You can make appropriate assumptions wherever required or search the internet for facts. State the assumptions made and the facts used clearly.
8. This is an individual assignment.
9. Then ideate against the above columns using the "Design Guidelines."
10. In case you can find less than 7 applicable columns for a particular dimension, you can compensate for it in another dimension.

Evaluation Questionnaire for G-SAM

1. Will you use or are using some sustainability principles in your BTP/ MTP/Ph.D.?
2. If Yes, how are you using it?
3. If No, why have you not used it or not willing to use it in the upcoming semester?
4. What is your opinion on sustainability/ design for sustainability?
5. Did you find the G-SAM toolkit useful in analyzing possible sustainability issues? How?
6. Did you find the G-SAM toolkit useful in ideating sustainable solutions? How?
7. Rate G-SAM on ease of use.
8. Do you think you can use the G-SAM - Rapid Assessment Checklist for gathering field data for an agricultural machinery design project?
9. Do you think you can use the G-SAM - Design Guideline for conducting a participatory design session for an agricultural machinery design project?
10. Rate G-SAM on relevance to use and implement with respect to not having any toolkit.

11. Sustainability implies making trade-offs. For example, having a manual washer is environmentally better but not very convenient on the human dimension. Does G-SAM help you identify these trade-offs?
12. Certain aspects of sustainability might not be under the direct control of the PSS stakeholders. These might be dependent on other global factors. Does G-SAM help you in identifying these global factors which are beyond the direct control of the PSS stakeholders?
13. Did you see that some of the G-SAM diagnostic features were related to each other, and their values affect each other? (So a change in values of one diagnostic feature would change another.)
14. Give one example of the above.
15. Does G-SAM help you imagine an agricultural machine as a component in a large system that also needs to be appropriately designed? How?
16. Does G-SAM help you in prioritizing sustainability targets?

Participant student designer details

Table A8. 1. Participant details

Student Code	Degree and year	Project Code Undertaken	Degree	Total number of participants
A	Ph.D., 1st year	TS	Ph.D.	1
B	Mdes, 2nd year	WM	Mdes	6
C	Mdes, 2nd year	WM	Bdes	8
D	Mdes, 2nd year	WM	Total	15
E	Mdes, 2nd year	WM		
F	Mdes, 2nd year	WM		
G	Mdes, 2nd year	WM		
H	Bdes, 4th year	TS		
I	Bdes, 4th year	TS		
J	Bdes, 4th year	TS		
K	Bdes, 4th year	TS		
L	Bdes, 4th year	WM		
M	Bdes, 4th year	TS		
N	Bdes, 4th year	TS		
O	Bdes, 4th year	WM		

Table A8. 2. Phase 1: Results of designing for SAM without any guidelines.

Student Code	Project Code	Number of Critical Features/ Diagnostic Criteria on the											
		Environmental Dimension				Economic Dimension				Social Dimension			
		Identified as applicable	Assessment done	Design ideas suggested	Factual errors/misunderstandings	Identified as applicable	Assessment done	Design ideas suggested	Factual errors/misunderstandings	Identified as applicable	Assessment done	Design ideas suggested	Factual errors/misunderstandings
B	WM	5	0	4	2	3	2	2	1	5	3	1	1
C	WM	2	0	1	1	3	0	1	1	4	0	1	1
D	WM	6	0	2	1	3	0	0	0	1	0	0	0
E	WM	2	0	1	3	1	0	0	2	1	0	1	1

F	W M	7	1	7	0	2	0	3	1	1	2	1	0
G	W M	4	0	3	0	2	0	1	1	2	1	1	0
L	W M	7	7	4	0	6	6	4	0	4	3	3	0
O	W M	3	0	3	0	2	0	2	0	2	0	3	0
Ave rage	W M	5	4	1	3	3	1	3	3	3	0		
					21%				29%				15%
A	TS	6	3	1	2	3	1	4	0	3	0	0	1
H	TS	2	2	3	0	0	0	0	0	1	0	2	0
I	TS	1	0	1	0	1	0	1	0	1	0	1	1
J	TS	2	1	3	1	1	0	1	0	2	0	3	0
K	TS	2	1	1	0	1	0	3	0	2	1	5	0
M	TS	1	0	1	1	2	1	2	0	2	2	2	0
N	TS	6	8	3	0	2	3	3	0	2	2	1	0
Ave rage	TS	3	4	1	1	3	0	2	3	0	2	3	0
					14%				0%				11%

Table A8. 3. Phase 2: Results of designing SAM with G-SAM.

Stu dent Cod e	Pro ject Co de	Number of Critical Features/ Diagnostic Criteria on the											
		Environmental Dimension				Economic Dimension				Social Dimension			
		Ident ified as appli cable	Asses sment done	Desi gn ideas sugg ested	Factual errors/ misunders tandings	Ident ified as appli cable	Asses sment done	Desi gn ideas sugg ested	Factual errors/ misunders tandings	Ident ified as appli cable	Asses sment done	Desi gn ideas sugg ested	Factual errors/ misunders tandings
B	W M	12	11	14	0	12	7	1	0	4	1	4	0
C	W M	12	3	4	4	7	4	3	2	5	2	3	2
D	W M	13	3	5	0	12	5	6	4	9	2	13	0
E	W M	7	3	6	0	6	3	5	0	8	3	5	1
F	W M	11	3	10	3	1	3	1	0	7	0	0	2
G	W M	15	10	13	1	7	3	8	1	6	0	11	0
L	W M	16	6	9	0	11	5	10	0	7	6	8	0
O	W M	11	7	11	1	11	8	15	0	4	2	2	0
Ave rage	W M	12	15	1	8	11	1	6	8	1	6	8	1
					8%				8%				8%
A	TS	11	12	11	0	2	2	2	0	7	7	9	0
H	TS	17	2	3	0	9	3	5	0	6	2	5	0

I	TS	15	2	2	0	10	5	2	0	9	3	3	0
J	TS	7	6	6	1	8	4	6	0	5	1	5	0
K	TS	16	4	17	1	6	3	1	0	3	2	2	0
M	TS	9	3	6	4	3	3	2	0	4	3	2	0
N	TS	8	4	8	0	7	5	5	0	6	1	8	0
Average	TS	12	12		1	6	7		0	6	8		0
					7%				0%				0%

Table A8. 4. Summary of evaluation of the G-SAM toolkit by the student designers.

Question No.	Evaluation Summary
1	Yes - 12, No - 3
2	Yes - Data shows the intent of use, but the use is less based on facts and inquiry but more common-sense knowledge. This implies the need for proper toolkits to aid them in design for sustainability process. No - Case 1 because of lack of knowledge, Case 2 because of the thought that it is of lesser priority, Case 3 open to using it in future Overall positive attitude towards design for sustainability and the cause and need for sustainability.
3	
4	
5	
6	Useful in opening their minds to the various aspects of sustainability, broadened their perspective, helped them see the systemic nature of the problem, and thus needed systemic thinking.
7	Difficult - 5, Just Right - 8, Easy - 2
8	Yes - 14, No answer - 1
9	Yes - 13, No - 2
10	<ul style="list-style-type: none"> • G-SAM is Helpful - 10 • G-SAM is Very Helpful - 5, because designing without a toolkit was <ul style="list-style-type: none"> ○ Difficult as there were fewer points to think about ○ Not aware of many features <ul style="list-style-type: none"> ○ Random ○ Difficult at times ○ Comparatively limited
11	Yes - 9, No - 6
12	Yes - 5, No - 9, No response - 1
13	Yes - 13, No - 2
14	<ul style="list-style-type: none"> • Could see the relation between service, system & product levels but not between the dimensions. <ul style="list-style-type: none"> • The link between socio-economic factors <ul style="list-style-type: none"> • Trade-off thinking between factors • The link between a product system and relevant service systems <ul style="list-style-type: none"> • Helped in deciding on the dimension to start the design with • Linked diagnostic features helped to relate between system, service, and product design levels
15	Yes - 10, No - 2, No response - 2, Ambiguous response - 1 Yes, comments - Shows the different perspectives, impact on socio-economic aspects, systemic viewpoint towards design, PSS thinking, machine in the context of the larger system. No comments - 1, others comment ambiguous.
16	Yes - 11, No - 4

Table A8. 5. Evaluation sheet raw data.

Student Code	Question Number	Response
A	1	No
	2	-
	3	The topic of universal design in building architecture is not having a scope to use sustainability.

	4	Products should be designed to be sustainable. It will lessen the load on waste management & lower the mixing of garbage & generation of toxic gases.
	5	It was useful & had new terms & perspectives the I did not know of G-SAM helped me to think thoroughly about different areas of sustainability.
	6	Yes, the guidelines were helpful and detailed.
	7	Difficult
	8	Yes
	9	Yes
	10	G-SAM is very helpful. Designing without toolkit was <u>difficult as there were less points to think about.</u>
	11	No
	12	No
	13	No
	14	The service, system & machine level were related but I could not relate environmental, economic & social factors.
	15	Yes, the different perspective related to it will help in designing a machine in a better way.
	16	Yes
B	1	Yes
	2	Sustainable system designed by adding participate design that due whole system of travel experience can continue
	3	-
	4	There are many dimension of sustainability while the course enlightened us and will be considering in our projects now
	5	G-SAM toolkit helped us to be aware of many future consideration which we were otherwise skip
	6	Yes, it helped in ideating at system level
	7	Just right
	8	-
	9	Yes
	10	G-SAM is helpful G-SAM is very helpful. Designing without a toolkit was <u>not be aware of many features</u>
	11	Yes
	12	Yes
	13	Yes
	14	If the product does help in creating economic value. It takes care of many other social economic factors.
	15	Yes, that how it will impact peoples lives on socio - economic factors
	16	Yes
C	1	Yes
	2	By using traditional methods and mixing with technology which helps to guide employees as well as customers experience improve
	3	-
	4	Sustainability – for me the current should be designed in such a way that it improvise and increase the productivity of work and do not reduce employment by creating or pulling forcefully technology in it
	5	Yes, but it can be designed in better way simple and interactive
	6	Yes to some extent it give me the multiple direction to think
	7	Just right
	8	Yes
	9	Yes
	10	G-SAM is helpful
	11	No

	12	Yes
	13	Yes
	14	Although manual washer is environmentally better but washing washing self sufficient reduce the jobs of thousands cloth washer. So we have to design in thinking in both perspective and direction.
	15	No, not much a existing machine all already good and can also be use with other machinery but current design need (LCL) addition for truck. Zinger
	16	Yes
D	1	Yes
	2	-Materials that can be recyclable -Social sustainability for the product to be used by various people
	3	-
	4	It is important to include sustainability aspects on on level social, economic and environmental. This makes the system more adaptable and admirable to use
	5	Yes it was very helpful. It gave fuel to the thoughts for ideation. It gave multiple dimensions to think on regarding a certain problem.
	6	Yes it was very useful as it helps to think on various aspects of PSS. It acted as a guide to develop new ideas.
	7	Easy
	8	Yes
	9	Yes
	10	G-SAM is very helpful. Designing without toolkit was random.
	11	Yes
	12	No
	13	Yes
	14	Changes in product system will affect changes in the relevant service system as well
	15	Yes. It helps to place the machinery in multiple dimensions of the society and ideate on various conditions that are provided in G-SAM.
	16	No
E	1	Yes
	2	By implementing electric technology
	3	-
	4	Good initiative. For great future. Eco-friendly.
	5	Yes, many terminology was not known. Because of G-SAM toolkit I came to known many aspect to be considered. For sustainability product.
	6	Yes, the points that were there in G-SAM toolkit was like data handbook, so it makes it easy to ideate with the boundary of sustainability.
	7	Just right
	8	Yes
	9	Yes
	10	G-SAM is helpful
	11	Yes
	12	Yes
	13	Yes
	14	-
	15	Yes
	16	Yes
F	1	Yes
	2	I use cardboard for making small prototype and rubber band for the stabilisation of the spoon - spoon made of clay and bamboo stick
	3	-

	4	So that products can easily be recycled on reuse to create less waste in our environment
	5	Yes, give me lots of idea on the environment. Social and economic conditions. And now we will consider in our design
	6	It is useful to create ideation on certain criteria. If something is left and it is useful to your system, that can we implement in your final sys.
	7	Difficult
	8	Yes
	9	Yes
	10	G-SAM is helpful
	11	Yes
	12	Yes
	13	Yes
	14	Most of the criteria affecting each other. Like water storage and the capacity of the truck.
	15	-
	16	Yes
G	1	Yes
	2	The components used should be bought out component, to avoid redesigning an entirely new component, reducing resource wastage
	3	-
	4	Minimal design and ensuring single part or component could be used multiple times
	5	It help me figure out some of the features, which I was not considering like system level applications and the service level applications.
	6	Held in considering factors for easy usage, manufacture ability, costing, revenue generation, profitability
	7	Just right
	8	Yes
	9	Yes
	10	G-SAM is helpful
	11	Yes
	12	No
	13	Yes
	14	Finding an alternate option for power which was electrical earlier anything other than electrical (unless manual) gives out environmental waste
	15	The proposed system should consider maintenance, spare parts availability, learn ability accessibility, profitability. (Reuse), revenue (recyclability) and loss in produce
	16	Yes
H	1	Yes
	2	Making it affordable and accessible to know income people making it easier to use
	3	-
	4	It is relating to the existing solutions and has to be considered or compromised on bass on the requirement.
	5	Yes, It helps me come across factors that I might have missed or not thought of.
	6	same as above
	7	Just right
	8	Yes
	9	Yes
	10	G-SAM is helpful
	11	No
	12	-
	13	Yes

	14	-
	15	Yes, it makes you think at different levels of design.
	16	Yes
I	1	Yes
	2	My Btp explore possibilities of biology nature in the future, thus promoting the idea of such is probably similar to working on our current sustainable solution, I feel.
	3	-
	4	Is much difficult to comprehend. Balancing out various parameters for the best possible result seems an added step in a conventional design process. But if the idea is well grassed then one can possibly think in that direction from the beginning.
	5	I tried to justify some of my or our ideas through the toolkit, not really generate much a new one. I would like to try that in an earlier concept phase.
	6	-
	7	Difficult
	8	Yes
	9	Yes, Definitely. Very much suited for participating or collaborative work.
	10	G-SAM is very helpful. Designing in a group without toolkit was difficult at times
	11	Yes
	12	No
	13	Yes
	14	I started off with social dimensions as that was how we approach the product too. Then economical, then environmental.
	15	No
	16	Yes
J	1	No
	2	-
	3	Most likely not because in the content of my Btp I think sustainability principles take second seat
	4	An important movment to make designer is more responsible for their creations
	5	Certain sustainability issues like business sustainability (optimising for future scope and growth)were not addressed earlier. On the economic dimension certain other issues and afterlife issues had not been considered yet.
	6	G-SAM toolkit aided in ideation up to an extent; however since in the project it was applied to we haven't gone in depth the rapid checklist was only applied hypothetically.
	7	Just right
	8	Yes
	9	No
	10	G-SAM is helpful
	11	No
	12	Yes
	13	No
	14	Couldn't see or escaped my eye
	15	Santacruz problems on three levels system, service and product. When being considered together G-SAM helps in imagining the machine as a component of a larger system
	16	Yes
K	1	Yes
	2	By applying system thinking, at varying levels – system and product. Analysing the interconnection between the product and the stakeholders.
	3	-
	4	An approach which must be applied when designing be it any project at hand. It helps the designers get an in-depth an insider perspective.
	5	Yes, the assessment criteria helped nudge our thoughts. They set as probes to further thanks and build upon.

	6	Could include visual cues for ideation. But shouldn't go very specific.
	7	Easy
	8	Yes
	9	Yes
	10	G-SAM is helpful
	11	Yes
	12	No
	13	Yes
	14	-
	15	Visual cues could be used to enhance the imagination process.
	16	Yes
L	1	No
	2	-
	3	Not used it yet. May consider using it in future.
	4	Sustainability is an important aspect to be considered in today's world
	5	Yes. The wide variety of options available really helps.
	6	Yes. It opens a perspective is that we did not consider previously.
	7	Just right
	8	Yes
	9	Yes
	10	G-SAM is helpful
	11	No
	12	No
	13	Yes
	14	Set of three diagnostic features related to system design, service design and product design by related
	15	Yes, as it is primarily meant for PSS design.
	16	No
M	1	Yes
	2	Tool that I am creating for farmer so the economic and social aspect need to be looked while design more than environmental sustainability
	3	-
	4	Sustainable design is required for the well-being of human and other living species and environment to go in a codependent way so to conserve future and resources.
	5	G-SAM toolkit mention different rapid assessment criteria to assess the product to make the product sustainable in future with consuming anything
	6	It gives different guidelines to follow while designing the product to ensure that it will be sustainable
	7	just right
	8	Yes
	9	Yes
	10	G-SAM is helpful
	11	Yes
	12	No
	13	Yes
	14	Like to design for overall safety the farmers the value the one diagnosis their shows one was to make it safe. But another diagnosis it shows the first diagnosis can be risky and need to change.
	15	-
	16	Yes
N	1	Yes

	2	It is a furniture design project. I use these principles to develop the design and also to evaluate my concepts.
	3	-
	4	Humans were gifted with wonderful resources and practical sustainable methods in life. modernisation, globalisation and industrialisation has degraded our health collectively. Hence design for sustainability is important in keeping or maintaining longer health.
	5	Yes! The toolkit acted as a checklist for the design to improve it
	6	Yes! It gives detailed list that creates an opportunity to ideate.
	7	difficult
	8	Yes
	9	Yes
	10	G-SAM is helpful
	11	Yes
	12	No
	13	Yes
	14	There were contradicting statements on using available resources to Max – which would result in more air pollution (G-SAM pointed out in being environmentally friendly).
	15	Yes: G-SAM shows how the design could be affected or could affect the greater ecosystem and predict the consequences.
	16	No
O	1	Yes
	2	I am trying to propose value addition in the kitchen wet waste in Indian households
	3	-
	4	In near future, sustainability is to be a necessity. Measure of carbon footprint might be an important scale to measure sustainable behavior and processes.
	5	Yes it was descriptive and gave multiple perspective of sustainability in a package. It was long though
	6	G-SAM helped to find or use apt keywords to find possibilities on Internet especially related to existing functioning firms or organizations.
	7	Difficult
	8	Yes
	9	No
	10	G-SAM is very helpful. Designing without work it was <u>comparatively limited</u> .
	11	No
	12	No
	13	Yes
	14	Partnerships
	15	Yes. It sheds light on the whole possible system
	16	No

Appendix 9

G-SAM Evaluation strategy 2 data

Evaluation Questionnaire

1. Name:
2. Bachelors:
3. Masters:
4. Ph.D.:

Before using G-SAM

5. How many other agricultural machineries you have designed earlier? _____ Tested _____ ?
6. How long have you been designing agricultural machinery? _____ Years _____ Months
7. Please pick up one of the agricultural machineries that you might have already designed or are designing and going to use for the evaluation of G-SAM. Explain the key design objectives of that agricultural machinery.

Or

Explain your Ph.D. research aims and hypothesis. Explain the key design objectives of the agricultural machinery that you are designing.

8. Did you use some principles of design for sustainability while designing the agricultural machinery? Please elaborate on them.

After using G-SAM

9. Will you use or are using some principles of sustainability in your current projects?
10. If Yes, how are you using it or will use it?
11. If No, why have you not used it or not willing to use it?
12. Your opinion on sustainability/ design for sustainability...
13. Did you find the G-SAM toolkit useful in analyzing possible sustainability issues? How?
14. Did you find the G-SAM toolkit useful in ideating sustainable solutions? How?
15. Rate G-SAM on ease of use.
16. Do you think you can use the G-SAM - Rapid Assessment Checklist for gathering field data for an agricultural machinery design project?
17. Do you think you can use the G-SAM - Design Guidelines for conducting a participatory design session for an agricultural machinery design project?
18. Rate G-SAM on relevance to use and implement with respect to not having any toolkit.
19. Sustainability implies making trade-offs. For example, having a manual washer is environmentally better but not very convenient on the human dimension. Does G-SAM help you identify these trade-offs?
20. Certain aspects of sustainability might not be under the direct the control of the PSS stakeholders. These might be dependent on other global factors. Example, Delhi's air pollution being caused to certain extent by farmers in neighboring states. Does G-SAM help you in identifying these global factors which are beyond the direct control of the PSS stakeholders.

21. Did you see that some of the G-SAM diagnostic features were related to each other and their values affected each other? (So change in values of one diagnostic feature would change another.)
22. Give one example of the above.
23. Does G-SAM help you in imagining an agricultural machine as a component in a large system which also needs to be appropriately designed? How?
24. Does G-SAM help you in prioritizing sustainability targets?
25. Your feedback on G-SAM.
26. How many new design ideas did it help you to generate for the project that you selected?

Table A9. 1. G-SAM evaluation sheet raw data.

Code	Question No.	Response
P	2	Industrial Design
	3	Service Design
	4	-
	5	0
	6	0 ; 0
	7	FISON pure electric autopilot tractor: Reduce the use of manpower in agricultural work and improve the efficiency of agricultural farming.
	8	Use electricity to reduce greenhouse gas emissions, improve farming efficiency, increase yields and reduce human labor.
	9	Yes
	10	It's hard to say, maybe I will use some of design principles. But I can not select which one is suitable, so I just check all of them, that action is a little painful.
	11	
	12	It's hard to say, maybe I will use some of design principles. But I can not select which one is suitable, so I just check all of them, that action is a little painful.
	13	It's hard to say, maybe I will use some of design principles. But I can not select which one is suitable, so I just check all of them, that action is a little painful.
	14	It's useful, but just what I mentioned above, it's a little difficult to use, and a lot of items mean you have to go through them like a checklist, one by one, rather than using a simple, easy-to-use tool.
	15	2.difficult
	16	No
	17	Yes
	18	1.G-SAM increases complexity
	19	No
	20	No
	21	Yes
	22	I don't think design can solve all problems in advance, although we are always looking for a balance among stakeholders. Perhaps the tools should be communicated to the subconscious through education rather than verification. If that means becoming more educational, I think design guidance is good.
	23	I think so, especially when it comes to thinking professionally. But on the other hand, having the product or PSS be tested by the market, and having the prototype iterated, may solve these agricultural specialty problems.
	24	Yes
	25	I think G-SAM has a very deep understanding of agriculture-related issues, but it should be considered about how to make it easier to use. Otherwise it will affect the communication and the original motivation of G-SAM. I think would be more useful to turn the design guidance into a more visual education of awareness.

	26	There are some piecemeal ideas, such as how to make the system gains more importance to local leaders and departments, so that they understand the value of this design. The another is how to make it easier to use, though this can be done through design training or better interaction design, but "How to" is the key.
Q	2	Industrial Design
	3	Industrial Design
	4	-
	5	0
	6	0 ; 0
	7	FISON pure electric autopilot tractor: Reduce the use of manpower in agricultural work and improve the efficiency of agricultural farming.
	8	Use electricity to reduce greenhouse gas emissions, improve farming efficiency, increase yields and reduce human labor.
	9	Yes
	10	Improvements to transport structures (e.g. wheels) to reduce damage to land farming capacity. Improve energy efficiency or consider cleaner energy sources. (e.g. solar energy) Consider designing components as replaceable to extend system life. Consider new usage and service models, such as short-term rentals or shared services. Consider reducing am's production costs. Develop a maintenance system.
	11	-
	12	I think DfS is an important design goal. In the long run, sustainability is a necessary condition for development
	13	Useful, for the selected project, can play a detail optimization of the design, improve sustainability.
	14	Useful, but limited to detail optimization.
	15	2.difficult
	16	No
	17	Yes
	18	4.G-SAM is helpful
	19	Yes
	20	Yes
	21	No
	22	-
	23	Yes, once the sustainability principles are understood, AM design is conceived into a potential system or service context, and more supportive service ideas are built around AM design
24	Yes	
25	1.G-SAM helped me better understand the sustainability principles of agriculture machinery design, which could be more helpful during the design phase. For a complete farm machine design, G-SAM can only play a complementary role in improving. 2.G-SAM's advice can lead to new design ideas, but while the designer integrates these ideas, he or she faces a difficult moment of trade-offs between the ideas. G-SAM lacks the analytical tools that evaluate the ideas and assist designers in making decisions. 3.Technical design guidelines lack easy-to-understand practical cases. 4. Too many entries, lack of ratings, highlights or visualization, causing evaluator reading burden.	
26	G-SAM helped me come up with a lot of interesting new ideas, but it's difficult to integrate these ideas into an existing project.	
R	2	Industrial Design
	3	Industrial Design
	4	-
	5	0
	6	0 ; 0

	7	DJI unmanned aerial vehicle is used to fertilize crops. It can reduce the harm to human during the process of fertilization.
	8	–
	9	Yes
	10	Before design, refer to the principles; during the process of design, refer the dimensions to improve the design.
	11	
	12	Sustainable design is a strategic design activity that builds and develops sustainable solutions, balancing economic, environmental, ethical and social issues.
	13	Yes, it can help me analyzing the project more systematically. But it is too many.
	14	–
	15	4.Easy
	16	Yes
	17	Yes
	18	5.G-SAM is helpful
	19	No
	20	Yes
	21	No
	22	–
	23	No, because the whole system is too complex, the product design is also complex. DJI unmanned aerial vehicle is helpful to farmer. Considering the service system, DJI design a platform to connect the farmer, the supplier of fertilizer and some teams that offer to maintain the farmland. It is a good design too.
	24	Yes
	25	As a designer in school our design usually is a concept, so when I use the G-SAM consider more about the environmental dimension, maybe most students are lack of the knowledge of economic. So, in the process of concept building is useful. It can used to evaluate the system in different stage. Each stage needs different dimensions.
	26	System design can consider to reduce the soil loss in the form of soil dust. It could have some new product to maintain the soil. Reduce the toxic of pesticide in the system. Keep crops healthy, use less of pesticide is better.
S	2	Industrial Design
	3	Industrial Design
	4	–
	5	–
	6	–
	7	<p>Design of Potato Harvester Based on Modular Design</p> <p>Design background:</p> <p>As one of the main food crops, potatoes are grown in many areas. Among them, the southwest mountainous area, mainly Guizhou, accounts for about one-third of the country's area. Folding root, also known as Houttuynia, grows in soil. The rhizomes are of the same origin in medicine and food, and are also grown in large areas in Guizhou. Because the cultivated land in this area is mostly terraced fields, small and scattered plots, the soil is generally sticky, the climate is humid and rainy, and the cultivation of agronomy is different. The imported models have poor adaptability problems, and the harvesting process is still mainly manual. In order to make the machine have a variety of configurations to effectively solve the mechanized harvest of potatoes and fold ears in the region, the design is based on a modular concept and developed a self-propelled small potato harvester.</p> <p>Key design goals:</p> <p>Through the modular design of the potato harvester, you can choose different combinations of alternative modules to derive harvesters with different functions, such as potatoes and fold ear harvesters. You can also configure potato harvesters with the same function but different performance</p>

	and different prices. Folding ear harvester to assist growers to efficiently complete the selection and use of machines for their cultivation conditions.
8	<p>Introducing modular ideas and technologies into the design of the potato harvester:</p> <p>(1) Public modules are beneficial to share, shortening the harvester R & D and manufacturing cycle. Based on the modular design method, the total functions of the potato harvester are divided into manipulation functions, mobile functions, auxiliary functions, and harvesting functions, and structural modules corresponding to each function are designed. Finally, the modules are assembled to complete the whole machine design. When designing a folding ear harvester, the designer can simply design or replace the harvesting function module based on the potato harvester, so that the folding ear harvester can be designed quickly and efficiently.</p> <p>(2) Reasonable prices and diverse functions to meet different needs of farmers. Most of the existing harvesters in the market are single-function and expensive, which is unaffordable for farmers in less developed mountain areas. The modular design has the following advantages in standardizing and serializing the module interface. First, it greatly reduces the types of parts. Most parts can be produced in batches or purchased directly. The selling price is more reasonable, and farmers can rent or buy directly during the harvest season; second, it is beneficial to the combination and exchange of different modules, which can harvest potatoes and folding ears to meet the farmers' diverse needs.</p> <p>(3) The module is easy to disassemble, maintain and upgrade, improving the overall performance of the machine.</p> <p>The potato harvester is roughly divided into power, manipulation, walking, depth limiting, rack, cutting, digging, earth moving, conveying, crushing, screening and other modules according to their functions. The connections between the modules are mostly connected using standard parts, which facilitates the disassembly and assembly between the modules. This makes the harvester highly adaptable in mountainous areas: when encountering narrow roads or slopes, the excavation module can be disassembled. Conducive to operation; especially if some modules are damaged during busy periods, the same modules can be replaced in time, so that the efficiency of agricultural machinery is not affected; in addition, when the machine is upgraded, it is not necessary to redesign the whole machine, only the upgraded module or Individual modules can meet the requirements.</p> <p>In general, the potato harvester under the concept of modularization not only saves resource costs from the perspective of machine parts production, core function components plus multi-point functional components to complete more tasks; but also forms a stable customer group, allowing sub-functional components to The development and upgrade has a stable market, which is also conducive to flexible iteration according to new market needs. At the same time, for low-income farmers, reduce the cost of machinery use, increase production value, and help them improve their living standards.</p>
9	Yes
10	In addition to dealing with the core issues of modularity, continue to study other sustainable perspectives, such as the impact of this product on soil and soil organisms that have not been previously studied, and consider further reference to design guidelines that focus on the economic dimension. business plan.
11	—
12	Before, we thought about sustainable design too one-sidedly, and equated it only with environmentally friendly environmental protection design. Now we understand that, especially for an entrepreneur, the design principles of sustainable design in the economic and social dimensions are also the same. Important guidance when considering business models.
13	It works. The toolkit is very specific, and there will be more systematic and in-depth thinking on the analysis one by one.
14	Yes. The toolkit is very specific, and there will be more systematic and in-depth thinking on the analysis one by one.

	15	3. Just right
	16	Yes
	17	Yes
	18	6. G-SAM is helpful
	19	Yes
	20	No
	21	-
	22	-
	23	Yes. G-SAM lets us not only focus on the design and research of the product itself, but also start to pay attention to many factors that can have relations with the product.
	24	No
	25	It is a very good tool, with a clear and organized framework, which has a positive significance for design verification and iterative thinking, and shows us the practical value and significance of sustainable design concepts. However, when it is used, the length of the entry is too much pressure on us. Most of the time, we will think about one or two content, it is unrealistic to consider all the content and improve it.
	26	-
T	2	Agricultural Engineering
	3	Farm Machinery
	4	Design, 4th year
	5	Tested 2
	6	0
	7	<ul style="list-style-type: none"> • To develop tool and technique for harvesting water chestnut crop. For harvesting of water chestnut workers are found to remain inside the water for the duration of 5 to 6 hours. Due to prolonged stay inside the water and humus, these workers suffer from various skin diseases and bacterial infections. • To study various factors that will affect the designs such as environmental, socio-economic, posture, physical properties of the crop. <ul style="list-style-type: none"> • To develop a prototype and test with the farmers. • Modification considering feedback.
	8	<ul style="list-style-type: none"> • As we are designing for base of pyramid, their capabilities for using/maintaining/troubleshooting will be considered. • No harmful effects on environment, cradle to cradle design.
	9	Yes
	10	<ul style="list-style-type: none"> • As we are designing for base of pyramid, their capabilities for using/maintaining/troubleshooting will be considered. • No harmful effects on environment, cradle to cradle design.
	11	-
	12	Sustainability is an important factor to consider in every design. Limited resources, waste of byproducts, climate change are saved on conserved with the help of sustainable design.
	13	I will find little difficulty in relating my topic area through G-SAM. As cultivation of water chestnut is completely different from other crops but I believe it can be helpful for other land crops.
	14	I will find little difficulty in relating my topic area through G-SAM. As cultivation of water chestnut is completely different from other crops but I believe it can be helpful for other land crops.
	15	Difficult
	16	Yes
	17	Yes
	18	-
	19	-
	20	-
	21	-
	22	-
	23	-

	24	-
	25	-
	26	-
U	2	Mechanical Engineering
	3	Mechanical Engineering
	4	Ph.D. In Centre for Rural Technology, 2nd year
	5	0
	6	1 Year
	7	Design of a ginger/ turmeric harvester for North-east India.
	8	The basic principles of sustainability in my project are: - optimization of site selection and procedure - minimization of energy consumption. - Use of low-cost and easily available manufacturing products. - Optimization of operational and maintenance practices
	9	Yes
	10	The basic principles of sustainability in my project are: - optimization of site selection and procedure - minimization of energy consumption. - Use of low-cost and easily available manufacturing products. - Optimization of operational and maintenance practices
	11	-
	12	The basic objective of sustainable design is to minimize negative environmental and other design associated impact through meaningful and sustainable design ideas. Sustainable design should integrate an environmentally friendly approach and consider nature resources as a part of the design.
	13	G-SAM toolkit is useful in analyzing possible sustainability issues as follows: - It helps in enhancing the creativity of the practitioners in various design fields. - This tool helps in improving the overall knowledge of the object for design. - It helps in improving the way of working, forcing practitioners to work in a more scientific way.
	14	It approaches focusing on improving existing on developing completely new products. Development of products towards integrated, products and services. Focuses on transport or mobility and thus on supporting transition to new system.
	15	3. Just right
	16	Yes
	17	Yes
	18	6. G-SAM is helpful
	19	No
	20	No
	21	-
	22	-
	23	-
	24	-
	25	Very informative toolkit. Many factors can be select at a single time. Use of this toolkit in the design procedure of agriculture will give a very fine output. Social consideration also leads to an important selection in this toolkit.
	26	Till now I am applying for one design only and it is at preliminary stage only. Therefore, G-SAM toolkit helps me in selection some more design areas apart from selection area.
	V	2
3		Design
4		Design Ph.D. (ongoing)
5		Designed 2, tested 2
6		5 years 3 months

7	Suitable for use in small land holding scenarios. Product maybe used by multiple people on a shared basis.
8	We used PLC stages to identify design requirements in development, use, maintenance, dissemination and disposal. Some material selection guidelines were used to select locally available and low energy intensive materials. Some social sustainability parameters were used to evaluate the product during testing.
9	Yes
10	Used the sustainable material and processes selection guidelines. Will use SDO toolkit and MSDS methodology in socially complex design solutions.
11	-
12	Aspects of design for sustainability must be considered as an integral part of the design process and must be implemented from the fuzzy front-end of the design process.
13	Yes. I used it as an ideation tool for considering modifications to the product design and strategy design aspects. Since these guidelines are derived from sustainability research, they will help to make the design more sustainable in all three dimensions.
14	Yes. The guidelines and the rapid assessment criteria can be used as prompts for ideation.
15	Difficult
16	Yes
17	Yes
18	G-SAM is very helpful. Designing without toolkit was making many of these aspects invisible during the design session.
19	No
20	Yes
21	Yes
22	Considering the system level category in the environmental section enabled me to see that there may be some energy issues in longer term and specially in low resource context.
23	Yes. It provides a holistic and more broad level abstract guidelines.
24	Yes
25	In its current form it is a bit complex to use. Complexity can be brought down by reducing the guidelines or re-organizing them. There may be a categorization which can be provided example if the analysis is to be done at a product level or system level or service level. A generic framework of when the tool is to be applied in the design process may be provided.
26	Around 10 in a shorter session. More ideas may be generated if more time is spent or if a participatory method is employed.

10. Bibliography

- Abdollahi, L., Hansen, E.M., Rickson, R.J., Munkholm, L.J., 2015. Overall assessment of soil quality on humid sandy loams: Effects of location, rotation and tillage. *Soil Tillage Res.* 145, 29-36.
- Abramovici, M., Aidi, Y., Quczada, A., Schindler, T., 2014. PSS sustainability assessment and monitoring framework (PSS-SAM) - Case study of a multi-module PSS solution, 6th CIRP Conference on Industrial Product Service Systems, IPSS 2014. Elsevier, Windsor, ON, pp. 140-145.
- Ackerman, F., Heinzlering, L., 2002. Pricing the priceless: Cost-benefit analysis of environmental protection. *University of Pennsylvania Law Review* 150(5), 1553-1584.
- Adams, R., Jeanrenaud, S., Bessant, J., Denyer, D., Overy, P., 2016. Sustainability-oriented innovation: A systematic review. *International Journal of Management Reviews* 18(2), 180-205.
- Adu-Baffour, F., Daum, T., Birner, R., 2019. Can small farms benefit from big companies' initiatives to promote mechanization in Africa? A case study from Zambia. *Food Policy* 84, 133-145.
- Afshar, M., Wang, D., 2010. Systems thinking for designing sustainable product service systems: A case study using a system dynamics approach. *Des. Princ. Pract.* 4(6), 259-273.
- Agriculture Census Division, 2011-12. Input survey, Agriculture Census Division, in: Department of Agriculture & Co-operation (Ed.). Ministry of Agriculture, Government of India, New Delhi.
- Aguilera, E., Guzmán, G.I., González de Molina, M., Soto, D., Infante-Amate, J., 2019. From animals to machines. The impact of mechanization on the carbon footprint of traction in Spanish agriculture: 1900–2014. *Journal of Cleaner Production* 221, 295-305.
- AIDOS, 1986. Women: The key to food security. <http://www.fao.org/docrep/x0171e/x0171e04.htm>. (Accessed June 15 2017).
- Alam, M.K., Biswas, W.K., Bell, R.W., 2016. Greenhouse gas implications of novel and conventional rice production technologies in the Eastern-Gangetic plains. *Journal of Cleaner Production* 112, 3977-3987.
- Alix, T., Zacharewicz, G., 2013. Product-service systems modelling and simulation as a strategic diagnosis tool, IFIP WG 5.7 International Conference on Advances in Production Management Systems, APMS 2012. Springer New York LLC, Rhodes, pp. 361-368.
- Allenby, B.R., 1994. Integrating environment and technology: Design for environment. The greening of industrial ecosystems, 137-148.
- Allione, C., De Giorgi, C., Lerma, B., Petrucci, L., 2012. From ecodesign products guidelines to materials guidelines for a sustainable product. Qualitative and quantitative multicriteria environmental profile of a material. *Energy* 39(1), 90-99.
- Altieri, M.A., 2008. Small farms as a planetary ecological asset: Five key reasons why we should support the revitalisation of small farms in the global south. Citeseer.
- Altieri, M.A., Koohafkan, P., 2008. Enduring farms: Climate change, smallholders and traditional farming communities. Third World Network (TWN) Penang.
- Alting, L., 1995. Life cycle engineering and design. *CIRP Annals* 44(2), 569-580.
- Araujo, C.S.J., 2001. Acquisition of product development tools in industry: A theoretical contribution, Department of Control and Engineering Design. Technical University of Denmark, Lyngby, Denmark.
- Aryal, J.P., Sapkota, T.B., Jat, M.L., Bishnoi, D.K., 2015. On-farm economic and environmental impact of zero-tillage wheat: A case of North-West India. *Experimental Agriculture* 51(1), 1-16.
- Asia and Pacific Commission on Agricultural Statistics, 2010. Characterisation of small farmers in Asia and the Pacific. Food and Agricultural Organization of the United Nations, Siem Reap, Cambodia, pp. 1-14.
- Auernhammer, K., Stabe, M., 2002. Integrated development of products and services, in: Mařík, V., Camarinha-Matos, L.M., Afsarmanesh, H. (Eds.), *Knowledge and Technology Integration in Production and Services: Balancing Knowledge and Technology in Product and Service Life Cycle*. Springer US, Boston, MA, pp. 367-374.
- Aurich, J.C., Fuchs, C., 2004. Life cycle oriented technical PSS design, SusProNet Conference Information Product Service Systems: Practical Value. Brussels, Belgium, p. 7.
- Aurich, J.C., Fuchs, C., Wagenknecht, C., 2006. Life cycle oriented design of technical product-service systems. *Journal of Cleaner Production* 14(17), 1480-1494.
- Bacenetti, J., Bava, L., Zucali, M., Lovarelli, D., Sandrucci, A., Tamburini, A., Fiala, M., 2016a. Anaerobic digestion and milking frequency as mitigation strategies of the environmental burden in the milk production system. *Sci. Total Environ.* 539, 450-459.
- Bacenetti, J., Facchinetti, D., Lovarelli, D., Pessina, D., 2020. Environmental impact alternatives for soil tillage and sowing: Farmer or contractor?, *Lecture Notes in Civil Engineering*. Springer, pp. 373-379.

- Bacenetti, J., Fusi, A., Negri, M., Fiala, M., 2015. Impact of cropping system and soil tillage on environmental performance of cereal silage productions. *Journal of Cleaner Production* 86, 49-59.
- Bacenetti, J., Lovarelli, D., Tedesco, D., Pretolani, R., Ferrante, V., 2018. Environmental impact assessment of alfalfa (*Medicago sativa* L.) hay production. *Sci. Total Environ.* 635, 551-558.
- Bacenetti, J., Pessina, D., Fiala, M., 2016b. Environmental assessment of different harvesting solutions for Short Rotation Coppice plantations. *Sci. Total Environ.* 541, 210-217.
- Badstue, L.B., Bellon, M.R., Berthaud, J., Ramírez, A., Flores, D., Juárez, X., Ramírez, F., 2005. Collective action for the conservation of on-farm genetic diversity in a center of crop diversity: An assessment of the role of traditional farmers' networks.
- Baines, T.S., Lightfoot, H.W., Evans, S., Neely, A., Greenough, R., Peppard, J., Roy, R., Shehab, E., Braganza, A., Tiwari, A., Alcock, J.R., Angus, J.P., Bastl, M., Cousens, A., Irving, P., Johnson, M., Kingston, J., Lockett, H., Martinez, V., Michele, P., Tranfield, D., Walton, I.M., Wilson, H., 2007. State-of-the-art in product-service systems. *P I Mech Eng B-J Eng* 221(10), 1543-1552.
- Banerjee, S., 2015. Case Study - Giving voice to the farmers, machine operators, local service providers and small scale manufacturers in designing scale-appropriate agro-machinery for rural Bangladesh, ICCIG3 2015. Ahmedabad.
- Banerjee, S., Puneekar, R.M., 2020. A sustainability-oriented design approach for agricultural machinery and its associated service ecosystem development. *Journal of Cleaner Production* 264.
- Barab, S., Squire, K., 2004. Design-based research: Putting a stake in the ground. *Journal of the Learning Sciences* 13(1), 1-14.
- Barros, N.N., Ruschel, R.C., 2021. Machine learning for whole-building life cycle assessment: A systematic literature review, in: Toledo Santos, E., Scheer, S. (Eds.), *Proceedings of the 18th International Conference on Computing in Civil and Building Engineering*. Springer International Publishing, Cham, pp. 109-122.
- Bartzas, G., Zaharaki, D., Komnitsas, K., 2015. Life cycle assessment of open field and greenhouse cultivation of lettuce and barley. *Inf. Process. Agric.* 2(3-4), 191-207.
- Baudron, F., Misiko, M., Getnet, B., Nazare, R., Sariah, J., Kaumbutho, P., 2019. A farm-level assessment of labor and mechanization in Eastern and Southern Africa. *Agron Sustain Dev* 39(2).
- Baudron, F., Sims, B., Justice, S., Kahan, D.G., Rose, R., Mkomwa, S., Kaumbutho, P., Sariah, J., Nazare, R., Moges, G., Gérard, B., 2015. Re-examining appropriate mechanization in Eastern and Southern Africa: Two-wheel tractors, conservation agriculture, and private sector involvement. *Food Security* 7(4), 889-904.
- Bausch, J.C., Bojórquez-Tapia, L., Eakin, H., 2014. Agro-environmental sustainability assessment using multicriteria decision analysis and system analysis. *Sustain. Sci.* 9(3), 303-319.
- Behrendt, S., Jasch, C., Peneda, M.C., van Weenen, H., 2012. *Life cycle design: a manual for small and medium-sized enterprises*. Springer Science & Business Media.
- Bélangier, V., Vanasse, A., Parent, D., Allard, G., Pellerin, D., 2012. Development of agri-environmental indicators to assess dairy farm sustainability in Quebec, Eastern Canada. *Ecol Indic* 23, 421-430.
- Benoist, A., Dron, D., Zoughaib, A., 2012. Origins of the debate on the life-cycle greenhouse gas emissions and energy consumption of first-generation biofuels - A sensitivity analysis approach. *Biomass Bioenergy* 40, 133-142.
- Bernardi, B., Falcone, G., Stillitano, T., Benalia, S., Strano, A., Bacenetti, J., De Luca, A.I., 2018. Harvesting system sustainability in Mediterranean olive cultivation. *Sci. Total Environ.* 625, 1446-1458.
- Bezruk, Y., Lavèn, P., Hoffmann, C., Doluschitz Dr, R., 2014. Sustainability in agricultural machinery production - An empirical study among farmers. *Landtechnik* 69(2), 84-88.
- Bhamra, T., Lofthouse, V., 2007. *Design for sustainability: A practical approach*. Gower Publishing, Ltd.
- Biggs, S., Justice, S., 2013. *Rural mechanization: A history of the spread of smaller-scale technology in selected Asian countries, a regional workshop on Rural Mechanization: Technology and Policy Lessons for Bangladesh and other Asian Countries*, Dhaka, Bangladesh.
- Biggs, S., Justice, S., Lewis, D., 2011. Patterns of rural mechanisation, energy and employment in South Asia: Reopening the debate. *Economic and Political Weekly*, 78-82.
- Binder, C., Wiek, A., 2007. The role of transdisciplinary processes in sustainability assessment of agricultural systems, From common principles to common practice. *Proceedings and outputs of the first symposium of the international forum on assessing sustainability in agriculture (INFASA)*. International Institute of Sustainable Development and Swiss College of Agriculture, Bern. pp. 33-48.
- Binder, C.R., Feola, G., Steinberger, J.K., 2010. Considering the normative, systemic and procedural dimensions in indicator-based sustainability assessments in agriculture. *Environmental Impact Assessment Review* 30(2), 71-81.
- Binder, C.R., Schmid, A., Steinberger, J.K., 2012. Sustainability solution space of the Swiss milk value added chain. *Ecological Economics* 83, 210-220.

- Bisht, I.S., Rana, J.C., Pal Ahlawat, S., 2020. The future of smallholder farming in India: Some sustainability considerations. *Sustainability* 12(9).
- Bisiaux, J., Gidel, T., Huet, F., Millet, D., 2015. The business model, a tool for transition to sustainable innovation, in: Marjanovic, D., Cantamessa, M., Weber, C., Husung, S., Cascini, G., Bordegoni, M. (Eds.), 20th International Conference on Engineering Design, ICED 2015, DS 80-01 ed. Design Society, pp. 43-52.
- Biswas, W.K., Graham, J., Kelly, K., John, M.B., 2010. Global warming contributions from wheat, sheep meat and wool production in Victoria, Australia—a life cycle assessment. *Journal of Cleaner Production* 18(14), 1386-1392.
- Björklund, T.A., 2013. Initial mental representations of design problems: Differences between experts and novices. *Design Stud* 34(2), 135-160.
- Blessing, L.T., Chakrabarti, A., 2009. *DRM: A design research methodology*. Springer.
- Bockstaller, C., Guichard, L., Keichinger, O., Girardin, P., Galan, M.-B., Gaillard, G., 2009. Comparison of methods to assess the sustainability of agricultural systems. A review. *Agron Sustain Dev* 29(1), 223-235.
- Boehm, M., Thomas, O., 2013. Looking beyond the rim of one's teacup: A multidisciplinary literature review of Product-Service Systems in Information Systems, Business Management, and Engineering & Design. *Journal of Cleaner Production* 51, 245-260.
- Bojacá, C.R., Wyckhuys, K.A.G., Schrevens, E., 2014. Life cycle assessment of Colombian greenhouse tomato production based on farmer-level survey data. *Journal of Cleaner Production* 69, 26-33.
- Bortolini, M., Cascini, A., Gamberi, M., Mora, C., Regattieri, A., 2014. Sustainable design and life cycle assessment of an innovative multi-functional haymaking agricultural machinery. *Journal of Cleaner Production* 82, 23-36.
- Breitschuh, G., Bachmann, G., 2008. *Kriteriensystem nachhaltige Landwirtschaft (KSNL): ein Verfahren zur Nachhaltigkeitsanalyse und Bewertung von Landwirtschaftsbetrieben*. KTBL.
- Breuer, T., Brenneis, K., Fortenbacher, D., 2015. Mechanisation—a catalyst for rural development in sub-Saharan Africa. *Rural* 21(49), 2.
- Brezet, H., Van Hemel, C., 1997. *Ecodesign : A promising approach to sustainable production and consumption*.
- Brezet, J.C., Bijma, A.S., Ehrenfeld, J., Silvester, S., 2001. The design of eco-efficient services: Method, tools and review of the case study from Designing Eco-Efficient Services project. *Design for Sustainability programme*, Delft University of Technology, The Netherlands.
- Briceno, T., Stagl, S., 2006. The role of social processes for sustainable consumption. *Journal of Cleaner Production* 14(17), 1541-1551.
- Brinks, H., Kool, S.D., 2006. *Farming with future: Implementation of sustainable agriculture through a network of stakeholders, Changing European Farming Systems for A Better Future: New Visions for Rural Areas*. Wageningen Academic Publishers, pp. 299-303.
- Brundtland Commission, 1987. *Report of the World Commission on Environment and Development: Our common future*. Oxford University Press.
- Buratti, C., Barbanera, M., Fantozzi, F., 2013. Assessment of GHG emissions of biomethane from energy cereal crops in Umbria, Italy. *Applied Energy* 108, 128-136.
- Byers, S.S., Groth, J.C., Sakao, T., 2015. Using portfolio theory to improve resource efficiency of invested capital. *Journal of Cleaner Production* 98, 156-165.
- Câmara-Salim, I., Almeida-García, F., González-García, S., Romero-Rodríguez, A., Ruíz-Nogueiras, B., Pereira-Lorenzo, S., Feijoo, G., Moreira, M.T., 2020. Life cycle assessment of autochthonous varieties of wheat and artisanal bread production in Galicia, Spain. *Sci. Total Environ.* 713.
- Cappelli, F., Delogu, M., Pierini, M., 2006. Integration of LCA and EcoDesign guideline in a virtual cad framework. *Proceedings of LCE*, 185-188.
- Cappelli, F., Delogu, M., Pierini, M., Schiavone, F., 2007. Design for disassembly: A methodology for identifying the optimal disassembly sequence. *Journal of Engineering Design* 18(6), 563-575.
- Cardoso, T.F., Watanabe, M.D.B., Souza, A., Chagas, M.F., Cavalett, O., Morais, E.R., Nogueira, L.A.H., Leal, M.R.L.V., Braunbeck, O.A., Cortez, L.A.B., Bonomi, A., 2018. Economic, environmental, and social impacts of different sugarcane production systems. *Biofuel Bioprod. Biorefining* 12(1), 68-82.
- Carranza-Gallego, G., Guzmán, G.I., García-Ruiz, R., González de Molina, M., Aguilera, E., 2018. Contribution of old wheat varieties to climate change mitigation under contrasting managements and rainfed Mediterranean conditions. *Journal of Cleaner Production* 195, 111-121.
- Cascini, A., Mora, C., Gamberi, M., Bortolini, M., Accorsi, R., Manzini, R., 2013. Design for sustainability of agricultural machines, 22nd International Conference on Production Research, ICPR 2013. International Foundation for Production Research (IFPR).
- Castanheira, E.G., Freire, F., 2013. Greenhouse gas assessment of soybean production: Implications of land use change and different cultivation systems. *Journal of Cleaner Production* 54, 49-60.

- Castanheira, É.G., Freire, F., 2012. Life-cycle GHG assessment of soybean biodiesel, 2012 IEEE International Symposium on Sustainable Systems and Technology, ISSST 2012. Boston, MA.
- Castoldi, N., Bechini, L., 2010. Integrated sustainability assessment of cropping systems with agro-ecological and economic indicators in northern Italy. *Eur J Agron* 32(1), 59-72.
- Catulli, M., 2012. What uncertainty? Further insight into why consumers might be distrustful of product service systems. *Journal of Manufacturing Technology Management* 23(6), 780-793.
- Cerdan, C., Gazulla, C., Raugei, M., Martinez, E., Fullana-i-Palmer, P., 2009. Proposal for new quantitative eco-design indicators: a first case study. *Journal of Cleaner Production* 17(18), 1638-1643.
- Cerutti, A.K., Calvo, A., Bruun, S., 2014. Comparison of the environmental performance of light mechanization and animal traction using a modular LCA approach. *Journal of Cleaner Production* 64, 396-403.
- Ceschin, F., 2013. Critical factors for implementing and diffusing sustainable product-service systems: insights from innovation studies and companies' experiences. *Journal of Cleaner Production* 45, 74-88.
- Ceschin, F., 2013. Sustainable product-service systems: Between strategic design and transition studies. Springer Science & Business Media.
- Ceschin, F., 2015. The role of socio-technical experiments in introducing sustainable product-service system innovations, *The Handbook of Service Innovation*. Springer-Verlag London Ltd, pp. 373-402.
- Ceschin, F., Gaziulusoy, I., 2016. Evolution of design for sustainability: From product design to design for system innovations and transitions. *Design Stud* 47, 118-163.
- Ceschin, F., Vezzoli, C., 2007. Sustainable product-service systems development. Application and evaluation of the SDOS (Sustainability Design-orienting Scenario) methodology for the upstream waste reduction in the food and in the paper chains in the city of Brescia. FHNW (School of Life Sciences-Institute for Ecopreneurship) 11th European Roundtable on Sustainable Consumption and Production (ERSCP 2007), 20-22.
- Chakrabarti, S., 2014. The gender advantage: Women on the front line of climate change. International Fund for Agricultural Development. Rome, Italy.
- Chakroun, M., Gogu, G., Pradel, M., Thirion, F., Lacour, S., 2010. Eco-design in the field of spreading technologies, 2nd Annual IEEE Green Technologies Conference. Grapevine, TX.
- Charter, M., Tischner, U., 2001. Sustainable solutions: Developing products and services for the future. Greenleaf publishing.
- Chavas, J.-P., Kim, K., 2007. Measurement and sources of economies of scope: A primal approach. *Journal of Institutional and Theoretical Economics (JITE) / Zeitschrift für die gesamte Staatswissenschaft* 163(3), 411-427.
- Chen, D., Chu, X., Yang, X., Sun, X., Li, Y., Su, Y., 2015. PSS solution evaluation considering sustainability under hybrid uncertain environments. *Expert Sys Appl* 42(14), 5822-5838.
- Chen, J., 2014. Introduction strategies of service-oriented product system design for the transformation and upgrading of small and medium manufacturers in China, 6th International Conference on Cross-Cultural Design, CCD 2014 - Held as Part of 16th International Conference on Human-Computer Interaction, HCI International 2014. Springer Verlag, Heraklion, Crete, pp. 14-23.
- Chen, Y.T., Chiu, M.C., 2014. A value creation based business model for customized product service system design, in: Curran, R., Xu, W., Chou, S.Y., Cha, J., Stjepandic, J. (Eds.), 21st ISPE Inc. International Conference on Concurrent Engineering: Moving Integrated Product Development to Service Clouds in the Global Economy, CE 2014. IOS Press BV, pp. 54-63.
- Cheng, S., Zheng, Z., Henneberry, S., 2019. Farm size and use of inputs: Explanations for the inverse productivity relationship. *China Agricultural Economic Review*.
- Chisawillo, P., 2015. Institutional collaboration in promoting mechanization for smallholder farmers, Bill and Melinda Gates Foundation Grand Challenges Annual Meeting. Beijing, China.
- Chiu, M.-C., Chu, C.-H., 2012. Review of sustainable product design from life cycle perspectives. *International Journal of Precision Engineering and Manufacturing* 13(7), 1259-1272.
- Chiu, M.C., Kuo, M.Y., Kuo, T.C., 2015. A systematic methodology to develop business model of a product service system. *Int J Ind Eng Theory Appl Pract* 22(3), 369-381.
- Chong, K.N., Dreijer, L.S., Howard, T.J., Birkved, M., Kreye, M.E., Bey, N., McAlloone, T.C., 2014. Comparing LCC with LCA to assess pss sustainability: The case of the eco-box, in: Marjanovic, D., Storga, M., Bojetic, N., Pavkovic, N. (Eds.), 13th International Design Conference, DESIGN 2014. Faculty of Mechanical Engineering and Naval Architecture, pp. 783-790.
- Chou, C.J., Chen, C.W., Conley, C., 2015. An approach to assessing sustainable product-service systems. *Journal of Cleaner Production* 86, 277-284.
- Chun, Y.Y., Kondoh, S., Mishima, N., Lee, K.M., 2010. A study on Total Performance Analysis of service oriented eco-businesses, 17th ISPE International Conference on Concurrent Engineering, CE 2010. Cracow, pp. 377-384.

- CIFOR, 1999. The CIFOR Criteria and Indicators Generic Template. Center for International Forestry Research (CIFOR), Jakarta, Indonesia.
- Clarke, L., 2000. Strategies for agricultural mechanization development: The roles of the private sector and the government. CIGR E-Journal 2.
- Clarke, L., Bishop, C., 2002. Farm power-present and future availability in developing countries. *Agricultural Engineering International: CIGR Journal of Scientific Research and Development* 4.
- Committee on Sustainability Assessment, COSA indicators - Master list. <https://data.thecosa.org/indicators-master-list/>. (Accessed 7 Jul 2017).
- Conway, G., 2011. On being a smallholder, Conference on new directions for smallholder agriculture. pp. 24-25.
- Cooley, L., Kohl, R., 2016. Scaling up—from vision to large-scale change: A management framework for practitioners, 3 ed. Management Systems International, Washington, DC.
- Copani, G., Rosa, P., 2015. DEMAT: Sustainability assessment of new flexibility-oriented business models in the machine tools industry. *International Journal of Computer Integrated Manufacturing* 28(4), 408-417.
- Corrado, S., Castellani, V., Zampori, L., Sala, S., 2018. Systematic analysis of secondary life cycle inventories when modelling agricultural production: A case study for arable crops. *Journal of Cleaner Production* 172, 3990-4000.
- Corti, D., Granados, M.H., Macchi, M., Canetta, L., 2015. Service-oriented business models for agricultural machinery manufacturers: Looking forward to improving sustainability, 19th International Conference on Engineering, Technology and Innovation, ICE 2013 and IEEE International Technology Management Conference, ITMC 2013. Institute of Electrical and Electronics Engineers Inc.
- COSA, 2013. The COSA Measuring Sustainability Report: Coffee and Cocoa in 12 Countries. The Committee on Sustainability Assessment Philadelphia, PA.
- Coteur, I., Marchand, F., Debruyne, L., Bijttebier, J., Triste, L., Lauwers, L., 2014. Development and evaluation of an on-demand sustainability tool in Flanders, 11th European IFSA symposium: Farming systems facing global challenges: capacities and strategies. International Farming Systems Association (IFSA) Europe; Leibniz-Centre for Agricultural Landscape Research (ZALF); Humboldt-Universität zu Berlin, pp. 38-48.
- Crul, M., Diehl, J.C., 2006. Design for sustainability (D4S): Manual and tools for developing countries. UNEP, Paris.
- D'Anna, W., Cascini, G., 2010. Supporting sustainable innovation through TRIZ system thinking, *Procedia Engineering*. Elsevier Ltd, pp. 145-156.
- Dahlström, H., 1999. Company-specific guidelines. *Journal of Sustainable Product Design*, 18-24.
- Dantsis, T., Douma, C., Giourga, C., Loumou, A., Polychronaki, E.A., 2010. A methodological approach to assess and compare the sustainability level of agricultural plant production systems. *Ecol Indic* 10(2), 256-263.
- Das, J., Khan, M.S., 2016. Women and aquaculture in Bangladesh: The unpaid labour. *Bangladesh e-Journal of Sociology* 13(1), 115.
- de Boer, I.J., Cornelissen, A.M., 2002. A method using sustainability indicators to compare conventional and animal-friendly egg production systems. *Poult Sci* 81(2), 173-181.
- De Gennaro, B., Notarnicola, B., Roselli, L., Tassielli, G., 2012. Innovative olive-growing models: An environmental and economic assessment. *Journal of Cleaner Production* 28, 70-80.
- de Mey, K., D'Haene, K., Marchand, F., Meul, M., Lauwers, L., 2011. Learning through stakeholder involvement in the implementation of MOTIFS: an integrated assessment model for sustainable farming in Flanders. *International Journal of Agricultural Sustainability* 9(2), 350-363.
- de Olde, E., Oudshoorn, F., Bokkers, E., Stubsgaard, A., Sørensen, C., de Boer, I., 2016. Assessing the sustainability performance of organic farms in Denmark. *Sustainability* 8(9), 20.
- de Olde, E.M., Oudshoorn, F.W., Sørensen, C.A., Bokkers, E.A., De Boer, I.J., 2016. Assessing sustainability at farm-level: Lessons learned from a comparison of tools in practice. *Ecol Indic* 66, 391-404.
- De Ridder, W., Turnpenny, J., Nilsson, M., Von Raggamby, A., 2010. A framework for tool selection and use in integrated assessment for sustainable development, *Tools, Techniques and Approaches for Sustainability: collected writings in environmental assessment policy and management*. World Scientific, pp. 125-143.
- de Roest, K., Ferrari, P., Knickel, K., 2018. Specialisation and economies of scale or diversification and economies of scope? Assessing different agricultural development pathways. *Journal of Rural Studies* 59, 222-231.
- Dewangan, K.N., Owary, C., Datta, R.K., 2008. Anthropometric data of female farm workers from north eastern India and design of hand tools of the hilly region. *International Journal of Industrial Ergonomics* 38(1), 90-100.
- Diao, X., Agandin, J., Fang, P., Justice, S.E., Kufoalor, D.S., Takeshima, H., 2018. Agricultural mechanization in Ghana: Insights from a recent field study. *Intl Food Policy Res Inst*.
- Directorate of Economics and Statistics, 2018. Agricultural statistics at a glance 2018, in: Department of Agriculture Cooperation & Farmers Welfare (Ed.). Ministry of Agriculture & Farmers Welfare, Government of India, New Delhi.

- Domingo, L., Brissaud, D., Mathieux, F., 2013. Implementing scenario to better address the use phase in product ecodesign.
- Dos Santos, A., Krämer, A., Vezzoli, C., 2009. Design brings innovation to the base of the pyramid. *Design Management Review* 20, 78-85.
- Draper, S., 2013. *Creating the big shift: System innovation for sustainability*. Forum for the Future London.
- Du Pisani, J.A., 2006. Sustainable development – historical roots of the concept. *Environmental Sciences* 3(2), 83-96.
- Dunmade, I., Rosentrater, K., 2006. *Designing for multi-lifecycle to promote industrial ecology philosophy, Environmentally Conscious Manufacturing VI*. Boston, MA.
- Eerdewijk, A.v., Danielsen, K., 2015. *Gender matters in farm power*. KIT, Amsterdam, The Netherlands.
- Ehrmann, M., Kleinhanß, W., 2008. Review of concepts for the evaluation of sustainable agriculture in Germany and comparison of measurement schemes for farm sustainability. *Arbeitsberichte aus der vTI-Agrarökonomie*.
- Elbushari, I.E., Aktaruzzaman, M., 2012. Identification of the problems and prospects in Vocational Education and Training (VET) of Bangladesh. *Asian Journal of Management Sciences and Education* 1(1), 76-89.
- Elhami, B., Akram, A., Khanali, M., 2016. Optimization of energy consumption and environmental impacts of chickpea production using data envelopment analysis (DEA) and multi objective genetic algorithm (MOGA) approaches. *Inf. Process. Agric.* 3(3), 190-205.
- Elhami, B., Khanali, M., Akram, A., 2017. Combined application of Artificial Neural Networks and life cycle assessment in lentil farming in Iran. *Inf. Process. Agric.* 4(1), 18-32.
- Elsaesser, M., Jilg, T., Herrmann, K., Boonen, J., Debruyne, L., Laidlaw, A., Aarts, F., 2015. Quantifying sustainability of dairy farms with the DAIRYMAN-sustainability-index. *Grassland science in Europe* 20, 367-376.
- Emili, S., Ceschin, F., Harrison, D., 2016. Product–Service System applied to Distributed Renewable Energy: A classification system, 15 archetypal models and a strategic design tool. *Energy Sustainable Dev.* 32, 71-98.
- Ensink, J.H., Brooker, S., Cairncross, S., Scott, C.A., 2006. Wastewater use in India: The impact of irrigation weirs on water quality and farmer health.
- Esdaille, R.J., Bell, R., Hossain, I., Haque, E., Sinath, P., Vial, L., 2009. Development of conservation farming implements for two-wheel tractors (power tillers) in Cambodia, Lao PDR and Bangladesh.
- ETC Group, 2009. Who will feed us? Questions for the food and climate crises. <https://www.etcgroup.org/content/who-will-feed-us>. (Accessed 12 August 2020).
- Ewemoje, T.A., Oluwaniyi, O.O., 2016. Mechanised shea butter production in south-western Nigeria using life cycle assessments (LCA) approach from gate-to-gate. *Agric. Eng. Int. CIGR J.* 18(2), 230-242.
- Fantozzi, F., Buratti, C., 2010. Life cycle assessment of biomass chains: Wood pellet from short rotation coppice using data measured on a real plant. *Biomass Bioenergy* 34(12), 1796-1804.
- FAO, 2011. *The state of food and agriculture. Women in agriculture: Closing the gender gap for development*. Food and Agriculture Organization of the United Nations, Rome, Italy.
- FAO, 2013a. *SAFA - Sustainability assessment of food and agriculture indicators - guidelines Version 3.0*. Food and Agriculture Organisation of the United Nations, Rome, p. 267.
- FAO, 2013b. *SAFA Sustainability assessment of food and agriculture indicators*. Food and Agriculture Organisation of the United Nations, Rome, p. 281.
- FAO, 2014. *The state of food and agriculture 2014: Innovation in family farming*. Food and Agriculture Organization of the United Nations, Rome, Italy.
- FAO, 2015. *Family Farming Knowledge Platform - Smallholders dataportrait*. <http://www.fao.org/family-farming/data-sources/dataportrait/farm-size/en/>. (Accessed 10 August 2020).
- FAO, 2016a. *Save and Grow in practice: maize, rice, wheat - A guide to sustainable cereal production*. Food and Agricultural Organization of the United Nations, Rome, Italy.
- FAO, 2016b. *Sustainable agricultural mechanization*. <http://www.fao.org/sustainable-agricultural-mechanization/overview/what-is-sustainable-mechanization/en/>. (Accessed 23 August 2020).
- FAO, 2016c. *Sustainable Development Goals - Indicator 2.3.1 - Volume of production per labour unit by classes of farming / pastoral / forestry enterprise size*. <http://www.fao.org/sustainable-development-goals/indicators/231/en/>. (Accessed 1st August 2020).
- FAO, 2016d. *Sustainable Development Goals - Indicator 2.3.2 - Average income of small-scale food producers, by sex and indigenous status*. <http://www.fao.org/sustainable-development-goals/indicators/232/en/>. (Accessed 1st August 2020).
- FAO, 2017. *Conservation Agriculture*. <http://www.fao.org/conservation-agriculture/en/>. (Accessed 23 Aug 2020).
- FAO, WFP, IFAD, 2015. *The state of food insecurity in the world 2015. Meeting the 2015 international hunger targets: Taking stock of uneven progress*. Food and Agriculture Organization of the United Nations, Rome, Italy.

- FAO Council, 1989. Sustainable development and natural resources management, Twenty-Fifth Conference, Paper C 89/2—Sup. 2. Rome, Italy.
- FAO Statistics, 2018. World food and agriculture statistical pocketbook 2018. Food and Agricultural Organization of the United Nations, Rome, Italy.
- FAO, U., 2008. Agricultural mechanization in Africa: Time for action, Planning investment for enhanced agricultural productivity report of an expert group meeting in January.
- Felten, D., Fröba, N., Fries, J., Emmerling, C., 2013. Energy balances and greenhouse gas-mitigation potentials of bioenergy cropping systems (*Miscanthus*, rapeseed, and maize) based on farming conditions in Western Germany. *Renew. Energy* 55, 160-174.
- Florindo, T.J., Bom de Medeiros Florindo, G.I., Ruviano, C.F., Pinto, A.T., 2020. Multicriteria decision-making and probabilistic weighing applied to sustainable assessment of beef life cycle. *Journal of Cleaner Production* 242.
- Fontana, M., Paciello, C., 2009. Gender dimensions of rural and agricultural employment: Differentiated pathways out of poverty—A global perspective, Institute of Development Studies at Sussex (England). Paper submitted to the FAO-IFAD-ILO Workshop on ‘Gaps, Trends and Current Research in Gender Dimensions of Agricultural and Rural Employment: Differentiated Pathways out of Poverty’ Rome.
- Fornasiero, R., Sorlini, M., 2010. Developing an assessment tool for innovation of product and service systems. *Int. J. Internet Manuf. Serv.* 2(2).
- Foteinis, S., Chatzisytheon, E., 2016. Life cycle assessment of organic versus conventional agriculture. A case study of lettuce cultivation in Greece. *Journal of Cleaner Production* 112, 2462-2471.
- Frog, 2013. The collective action toolkit.
- Fusakul, S.M., Siridej, P., 2010. DSEP: Implementation of Sufficiency Economy Philosophy In design. *Sustainability in Design: Now*, 178-190.
- Fusi, A., Bacenetti, J., Gonza'lez-Garci'a, S., Vercesi, A., Bocchi, S., Fiala, M., 2014. Environmental profile of paddy rice cultivation with different straw management. *Sci. Total Environ.* 494-495, 119-128.
- Gaha, R., Benamara, A., Yannou, B., 2011. Influence of geometrical characteristics on ecodesigned products, *Proc. of the Int. Conf. on Innovation Methods in Product Design*. pp. 242-247.
- Gandhi, V.P., Namboodiri, N., 2009. Groundwater irrigation in India: Gains, costs and risks.
- Garetti, M., Rosa, P., Terzi, S., 2012. Life Cycle simulation for the design of product-service systems. *Computers in Industry* 63(4), 361-369.
- Garner, E., de la O Campos, A.P., 2014. Identifying the family farm. An informal discussion of the concepts and definitions.
- Gartaula, H., Niehof, A., Visser, L., 2012. Shifting perceptions of food security and land in the context of labour out-migration in rural Nepal. *Food Security* 4(2), 181-194.
- Gasparatos, A., 2010. Embedded value systems in sustainability assessment tools and their implications. *J. Environ. Manage.* 91(8), 1613-1622.
- Gasparatos, A., El-Haram, M., Horner, M., 2008. A critical review of reductionist approaches for assessing the progress towards sustainability. *Environmental impact assessment review* 28(4-5), 286-311.
- Gathorne-Hardy, A., 2016. The sustainability of changes in agricultural technology: The carbon, economic and labour implications of mechanisation and synthetic fertiliser use. *Ambio* 45(8), 885-894.
- Gaziulusoy, A.I., Boyle, C., McDowall, R., 2013. System innovation for sustainability: A systemic double-flow scenario method for companies. *Journal of Cleaner Production* 45, 104-116.
- Geerts, G.L., 2011. A design science research methodology and its application to accounting information systems research. *International Journal of Accounting Information Systems* 12(2), 142-151.
- Gehin, A., Zwolinski, P., Brissaud, D., 2008. A tool to implement sustainable end-of-life strategies in the product development phase. *Journal of Cleaner Production* 16(5), 566-576.
- Germani, M., Dufrene, M., Mandolini, M., Marconi, M., Zwolinski, P., 2013a. Integrated software platform for green engineering design and product sustainability, *Re-engineering manufacturing for sustainability*. Springer, pp. 87-92.
- Germani, M., Mandolini, M., Marconi, M., Morbidoni, A., Rossi, M., 2013b. A case-based reasoning approach to support the application of the eco-design guidelines, *Re-engineering Manufacturing for Sustainability*. Springer, pp. 81-86.
- Gerrard, C.L., Smith, L., Pearce, B., Padel, S., Hitchings, R., Cooper, N., 2012. Public goods and farming, *Farming for food and water security*. Springer, pp. 1-22.
- Geum, Y., Park, Y., 2010. Development of technology roadmap for product-service system (TRPSS), *IEEE International Conference on Industrial Engineering and Engineering Management, IEEM2010*. Macao, pp. 410-414.
- Geum, Y., Park, Y., 2011. Designing the sustainable product-service integration: A product-service blueprint approach. *Journal of Cleaner Production* 19(14), 1601-1614.

- Gibbs, H.K., Salmon, J.M., 2015. Mapping the world's degraded lands. *Applied Geography* 57, 12-21.
- Giovannucci, D., Potts, J., Killian, B., Wunderlich, C., Soto, G., Schuller, S., Pinard, F., Schroeder, K., Vagneron, I., 2008. Seeking sustainability: COSA preliminary analysis of sustainability initiatives in the coffee sector. Committee on Sustainability Assessment.
- Giudice, F., La Rosa, G., Risitano, A., 2001. Optimisation and cost-benefit analysis of product recovery-cycles, Proceedings of the 13th International Conference on Engineering Design, Glasgow.
- Giudice, F., La Rosa, G., Risitano, A., 2005. Materials selection in the life-cycle design process: A method to integrate mechanical and environmental performances in optimal choice. *Materials & Design* 26(1), 9-20.
- Glatt, M.F., Yi, L., Mert, G., Linke, B.S., Aurich, J.C., 2019. Technical Product-Service Systems: Analysis and reduction of the Cumulative Energy Demand. *Journal of Cleaner Production* 206, 727-740.
- Gleasure, R., Feller, J., O'Flaherty, B.F., 2012. Procedurally transparent design science research: A design process model, ICIS 2012.
- Gliessman, S.R., 1987. Species interactions and community ecology in low external-input agriculture. *American Journal of Alternative Agriculture* 2(4), 160-165.
- Global Reporting Initiative, 2014. G4 food processing sector disclosures. <https://www.globalreporting.org/resourcelibrary/GRI-G4-Food-Processing-Sector-Disclosures.pdf>. (Accessed December 2016).
- Goedkoop, M.J., van Halen, C.J., te Riele, H.R., Rommens, P.J., 1999. Product service systems, ecological and economic basics. 1999. VROM: Hague, the Netherlands.
- Goglio, P., Bonari, E., Mazzoncini, M., 2012. LCA of cropping systems with different external input levels for energetic purposes. *Biomass Bioenergy* 42, 33-42.
- Gómez, J.A.L., Van Loon, J., 2018. Agrotechnical evaluation of manual implements for corn planting. *Revista mexicana de ciencias agrícolas* 21, 4258-4269.
- González-García, S., Baucells, F., Feijoo, G., Moreira, M.T., 2016. Environmental performance of sorghum, barley and oat silage production for livestock feed using life cycle assessment. *Resources, Conservation and Recycling* 111, 28-41.
- González-García, S., Castanheira, E.G., Dias, A.C., Arroja, L., 2013. Environmental performance of a Portuguese mature cheese-making dairy mill. *Journal of Cleaner Production* 41, 65-73.
- González-García, S., Hospido, A., Feijoo, G., Moreira, M.T., 2010. Life cycle assessment of raw materials for non-wood pulp mills: Hemp and flax. *Resources, Conservation and Recycling* 54(11), 923-930.
- González-García, S., Moreira, M.T., Feijoo, G., Murphy, R.J., 2012. Comparative life cycle assessment of ethanol production from fast-growing wood crops (black locust, eucalyptus and poplar). *Biomass Bioenergy* 39, 378-388.
- Goshu, M.T., 2007. The optimum design parameters for a rotary blade power tiller under unsaturated sandy clay loam condition, Tropical Agriculture. Graduate School, Kasetsart University.
- Government of India, 2014a. Agriculture Census 2010-11 - All India report on number and area of operational holdings, in: Agriculture Census Division, Department of Agriculture & Co-operation, Ministry of Agriculture (Eds.). GOVERNMENT OF INDIA, p. 97.
- Government of India, 2014b. Sub-Mission on Agricultural Mechanization - Operational guidelines (Twelfth Five Year Plan), in: Mechanization & Technology Division, Department of Agriculture, Cooperation and Farmers Welfare, Ministry of Agriculture and Farmers Welfare (Eds.). Government of India, Krishi Bhavan, New Delhi.
- Government of Punjab, 2002. Expert committee report on agricultural production pattern adjustment programme in Punjab for productivity and growth (Chairman: S. S. Johl). Government of Punjab, India.
- Government of Punjab, 2005. Statistical abstract of Punjab, 2004, in: Economic Adviser to Govt. of Punjab (Ed.). Publication No. 905, Chandigarh.
- Grados, D., Schrevens, E., 2019. Multidimensional analysis of environmental impacts from potato agricultural production in the Peruvian Central Andes. *Sci. Total Environ.* 663, 927-934.
- Graedel, T., Allenby, B.R., 2010. *Industrial Ecology and Sustainable Engineering: International Edition*. Pearson Education Inc., Upper Saddle River, Prentice Hall.
- GRAIN, 2014. Hungry for land: Small farmers feed the world with less than a quarter of all farmland.
- Gregg, E.S., Colton, J., Matin, M.A., Krupnik, T.J., 2020. Efficient and participatory design of scale-appropriate agricultural machinery workshops in developing countries: A case study in Bangladesh. *Development Engineering* 5.
- Grenz, J., 2011. Response-Inducing Sustainability Evaluation (RISE) Version 2.0. Swiss College of Agriculture.
- Grenz, J., Sereke, F., 2017. Response-Inducing Sustainability Evaluation (RISE) Version 3.0. Bern University of Applied Sciences, School of Agricultural, Forest and Food Sciences.
- Grenz, J., Thalmann, C., Stämpfli, A., Studer, C., Häni, F., 2009. RISE—a method for assessing the sustainability of agricultural production at farm level. *Rural Development News* 1(2009), 5-6.

- GRI, 2011a. Sustainability reporting guidelines. Global Reporting Initiative, Amsterdam.
- GRI, 2011b. Sustainability reporting guidelines & food processing sector supplement. Global Reporting Initiative, Amsterdam.
- Grüneisen, P., Stahl, B., Kasperek, D., Maurer, M., Lohmann, B., 2015. Qualitative System Dynamics cycle network of the innovation process of Product Service Systems, in: Brissaud, D., Boucher, X. (Eds.), 7th CIRP Industrial Product-Service Systems Conference, IPSS 2015. Elsevier B.V., pp. 120-125.
- Guerci, M., Knudsen, M.T., Bava, L., Zucali, M., Schönbach, P., Kristensen, T., 2013. Parameters affecting the environmental impact of a range of dairy farming systems in Denmark, Germany and Italy. *Journal of Cleaner Production* 54, 133-141.
- Guijt, I., Moiseev, A., 2001. IUCN resource kit for sustainability assessment. IUCN, Gland, Switzerland and Cambridge, UK.
- Gunady, M.G.A., Biswas, W., Solah, V.A., James, A.P., 2012. Evaluating the global warming potential of the fresh produce supply chain for strawberries, romaine/cos lettuces (*Lactuca sativa*), and button mushrooms (*Agaricus bisporus*) in Western Australia using life cycle assessment (LCA). *Journal of Cleaner Production* 28, 81-87.
- Güngör, A., 2006. Evaluation of connection types in design for disassembly (DFD) using analytic network process. *Computers & Industrial Engineering* 50(1-2), 35-54.
- Gupta, A.K., 1999. Science, sustainability and social purpose: Barriers to effective articulation, dialogue and utilization of formal and informal science in public policy. *International Journal of Sustainable Development* 2, 368-371.
- Gupta, A.K., 2010. Grassroots green innovations for inclusive, sustainable development.
- Gupta, S., Sarkar, P., Singla, E., 2015. Understanding different stakeholders of sustainable product and service-based systems using genetic algorithm. *Clean Technol. Environ. Policy* 17(6), 1523-1533.
- Guzman, J.G., Lal, R., Byrd, S., Apfelbaum, S.I., Thompson, R.L., 2016. Carbon life cycle assessment for Prairie as a crop in reclaimed mine land. *Land Degrad. Dev.* 27(4), 1196-1204.
- Gyi, D., Cain, R., Campbell, R., 2006. Facilitating 'user push' in the design process, IEA2006: 16th World Congress on Ergonomics. Elsevier Ltd Maastricht, pp. 10-14.
- Haas, G., Wetterich, F., Geier, U., 2000. Life cycle assessment framework in agriculture on the farm level. *The International Journal of Life Cycle Assessment* 5(6).
- Hallstedt, S., Ny, H., Robèrt, K.-H., Broman, G., 2010. An approach to assessing sustainability integration in strategic decision systems for product development. *Journal of Cleaner Production* 18(8), 703-712.
- Hallstedt, S., Thompson, A.W., Isaksson, O., Larsson, T.C., Ny, H., 2013. A decision support approach for modeling sustainability consequences in an aerospace value chain, ASME 2013 International Design Engineering Technical Conferences and Computers and Information in Engineering Conference, IDETC/CIE 2013. American Society of Mechanical Engineers, Portland, OR.
- Halme, M., Anttonen, M., Hrauda, G., Kortman, J., 2006. Sustainability evaluation of European household services. *Journal of Cleaner Production* 14(17), 1529-1540.
- Halme, M., Jasch, C., Scharp, M., 2004. Sustainable homeservices? Toward household services that enhance ecological, social and economic sustainability. *Ecological Economics* 51(1-2), 125-138.
- Hayati, D., 2017. A literature review on frameworks and methods for measuring and monitoring sustainable agriculture. Technical Report.
- Hayati, D., Ranjbar, Z., Karami, E., 2010. Measuring agricultural sustainability.
- Hecher, M., 2011. Beurteilung der Zusammenhänge von wirtschaftlicher Entwicklung und Umweltauswirkungen. University of Graz in collaboration with the Federal Ministry of Agriculture, Forestry, Environment and Water Management. Graz, Austria, in Binder, C.R., Schmid, A., Steinberger, J.K., 2012. Sustainability solution space of the Swiss milk value added chain. *Ecological Economics* 83, 210-220.
- Hedayati, M., Brock, P.M., Nachimuthu, G., Schwenke, G., 2019. Farm-level strategies to reduce the life cycle greenhouse gas emissions of cotton production: An Australian perspective. *Journal of Cleaner Production* 212, 974-985.
- Heidhues, F., Brüntrup, M., 2003. Subsistence agriculture in development: Its role in processes of structural change, in: Abele, S., Froberg, K. (Eds.), Subsistence agriculture in Central and Eastern Europe: How to break the vicious circle. Institute of Agricultural Development in Central and Eastern Europe, Institut für Agrarentwicklung in Mittel-und Osteuropa (IAMO), Theodor-Lieser-Straße 2, Halle (Saale), pp. 1-27.
- Heilala, J., Ruusu, R., Montonen, J., Vatanen, S., Kavka, C., Asnicar, F., Scholze, S., Armijojo, A., Insunza, M., 2014. Eco-process Engineering System for Collaborative Product Process System Optimisation, IFIP WG 5.7 International Conference on Advances in Production Management Systems, APMS 2014. Springer New York LLC, Ajaccio, pp. 634-641.
- Heiskanen, E., 2002. The institutional logic of life cycle thinking. *Journal of Cleaner Production* 10(5), 427-437.

- Hendrickson, J., Sassenrath, G.F., Archer, D., Hanson, J., Halloran, J., 2008. Interactions in integrated US agricultural systems: The past, present and future. *Renew. Agr. Food Syst.* 23(4), 314-324.
- Herrero, M., Thornton, P.K., Power, B., Bogard, J.R., Remans, R., Fritz, S., Gerber, J.S., Nelson, G., See, L., Waha, K., Watson, R.A., West, P.C., Samberg, L.H., van de Steeg, J., Stephenson, E., van Wijk, M., Havlík, P., 2017. Farming and the geography of nutrient production for human use: A transdisciplinary analysis. *The Lancet Planetary Health* 1(1), e33-e42.
- Herrington, J., Herrington, A., Olney, I., 2012. Mobile learning in higher education: Authentic tasks, assessment and Web 2.0, EdMedia+ Innovate Learning. Association for the Advancement of Computing in Education (AACE), pp. 1988-1993.
- Herzog, M., Meuris, D., Bender, B., Sadek, T., 2014. The nature of risk management in the early phase of IPS2 design, 6th CIRP Conference on Industrial Product Service Systems, IPSS 2014. Elsevier, Windsor, ON, pp. 223-228.
- Hilmi, M., 2013. Hire services as a business: The potential for developing business enterprises with tractors, machinery and draught animals. *Agriculture for Development*(19), 21-24.
- Hirschl, B., Konrad, W., Scholl, G., 2003. New concepts in product use for sustainable consumption. *Journal of Cleaner Production* 11(8), 873-881.
- Holloway, L., 1998. Materials selection for optimal environmental impact in mechanical design. *Materials & Design* 19(4), 133-143.
- Horrigan, L., Lawrence, R.S., Walker, P., 2002. How sustainable agriculture can address the environmental and human health harms of industrial agriculture? *Environ Health Perspect* 110(5), 445-456.
- Hossain, M.A., Sultana, N., Biswas, S., 2015. A proportional study and analysis: evaluation the effectiveness of word of mouth marketing in opposition to traditional advertising concerning medical treatment facilities in Bangladesh. *Manag Organ Stud* 2(1).
- Hossain, M.I., Islam, M.S., Hossain, I., Meisner, C.A., Rahman, M.S., 2010. Seeding performance of two wheel tractor operated bed planter for cereal crop establishment. *International Journal of Energy Machinery* 3, 63-69.
- Hossain, M.M., Kabir, S., Rezvi, R.I., 2017. Influence of word of mouth on consumer buying decision: Evidence from Bangladesh market. *European Journal of Business and management* 9(12), 38-45.
- Houmy, K., Clarke, L.J., Ashburner, J.E., Kienzle, J., 2013. Agricultural mechanization in sub-Saharan Africa: Guidelines for preparing a strategy. Food and Agriculture Organization of the United Nations (FAO).
- Houshyar, E., Grundmann, P., 2017. Environmental impacts of energy use in wheat tillage systems: A comparative life cycle assessment (LCA) study in Iran. *Energy* 122, 11-24.
- Hu, H.A., Chen, S.H., Hsu, C.W., Wang, C., Wu, C.L., 2012. Development of sustainability evaluation model for implementing product service systems. *International Journal of Environmental Science and Technology* 9(2), 343-354.
- Huang, A., Wijekoon, K., Badurdeen, F., 2012. Goal programming-based approach to identify sustainable product service system designs, in: Dornfeld, D.A., Linke, B.S. (Eds.), 19th CIRP Conference on Life Cycle Engineering, LCE 2012. Springer Berlin Heidelberg, pp. 19-24.
- Huisman, J., Boks, C., Stevels, A., 2003. Quotes for environmentally weighted recyclability (QWERTY): Concept of describing product recyclability in terms of environmental value. *International Journal of Production Research* 41(16), 3649-3665.
- Igos, E., Golkowska, K., Koster, D., Vervisch, B., Benetto, E., 2016. Using rye as cover crop for bioenergy production: An environmental and economic assessment. *Biomass Bioenergy* 95, 116-123.
- Iivari, J., Venable, J., 2009. Action research and design science research—seemingly similar but decisively dissimilar, 17th European conference on information systems. pp. 1-13.
- Ijomah, W.L., McMahon, C.A., Hammond, G.P., Newman, S.T., 2007. Development of design for remanufacturing guidelines to support sustainable manufacturing. *Robotics and Computer-Integrated Manufacturing* 23(6), 712-719.
- Ilsen, R., Herder, C., Aurich, J.C., 2015. Assessment of energetic leverage effect using a virtual prototype, in: Erkoyuncu, J. (Ed.) 4th CIRP Global Web Conference, CIRPe 2015. Elsevier B.V., pp. 36-41.
- Indian Council of Food and Agriculture, 2017. Farm mechanization - national round table conference. New Delhi, India.
- Ingrao, C., Matarazzo, A., Tricase, C., Clasadonte, M.T., Huisingh, D., 2015. Life Cycle Assessment for highlighting environmental hotspots in Sicilian peach production systems. *Journal of Cleaner Production* 92, 109-120.
- International Fund for Agricultural Development, Japan Official Development Assistance, 1998. Agricultural implements used by women farmers in Africa. IFAD.
- International Institute of Rural Reconstruction, 2000. Going to scale: Can we bring more benefits to more people more quickly? IIRR Philippines.

- International Standard Organization, 2009. Environmental management – Life cycle assessment – Principles and framework (ISO 14040:2006). Deutsches Institut für Normung e.V., Berlin.
- Iriarte, A., Rieradevall, J., Gabarrell, X., 2011. Environmental impacts and energy demand of rapeseed as an energy crop in Chile under different fertilization and tillage practices. *Biomass Bioenergy* 35(10), 4305-4315.
- ISEAL Alliance, 2010. Assessing the impacts of environmental and social standards systems. ISEAL Alliance, London.
- Islam, M.N., 2014. Availability of data related to Technical and Vocational Education and Training (TVET) in Bangladesh. People's Republic of Bangladesh Technical and Vocational Education and Training (TVET), Funded by the European Union and executed by the ILO, Dhaka, Bangladesh.
- Jain, P., 2009. Design of an interactive eco assessment GUI tool for computer aided product design, Department of Design. Indian Institute of Technology Guwahati, Guwahati.
- Järvinen, P., 2007. Action research is similar to design science. *Quality & Quantity* 41(1), 37-54.
- Jat, M.L., Gathala, M.K., Ladha, J.K., Saharawat, Y.S., Jat, A.S., Kumar, V., Sharma, S.K., Kumar, V., Gupta, R., 2009. Evaluation of precision land leveling and double zero-till systems in the rice-wheat rotation: Water use, productivity, profitability and soil physical properties. *Soil Tillage Res.* 105(1), 112-121.
- Jat, M.L., Kamboj, B.R., Sidhu, H.S., Singh, M., Bana, A., Bishnoi, D.K., Gathala, M.K., Saharawat, Y.S., Kumar, V., Kumar, A., 2013. Operational manual for Turbo Happy Seeder-Technology for managing crop residues with environmental stewardship.
- Jelsma, J., Knot, M., 2002. Designing environmentally efficient services; a 'script' approach. *The Journal of Sustainable Product Design* 2(3-4), 119-130.
- Jerneck, A., Olsson, L., Ness, B., Anderberg, S., Baier, M., Clark, E., Hickler, T., Hornborg, A., Kronsell, A., Lövbrand, E., Persson, J., 2010. Structuring sustainability science. *Sustain. Sci.* 6(1), 69-82.
- Johansen, C., Haque, M.E., Bell, R.W., Thierfelder, C., Esdaile, R.J., 2012. Conservation agriculture for small holder rainfed farming: Opportunities and constraints of new mechanized seeding systems. *Field Crop. Res.* 132, 18-32.
- Johansson, A., Kisch, P., Mirata, M., 2005. Distributed economies - A new engine for innovation. *Journal of Cleaner Production* 13(10-11), 971-979.
- Johnson, E.F., Gay, A., 1995. A practical, customer-oriented DFE methodology, Proceedings of the 1995 IEEE International Symposium on Electronics and the Environment ISEE (Cat. No. 95CH35718). IEEE, pp. 47-50.
- Jones, E., Harrison, D., McLaren, J., 2001a. Managing creative eco-innovation—structuring outputs from eco-innovation projects. *The Journal of Sustainable Product Design* 1(1), 27-39.
- Jones, E., Stanton, N., Harrison, D., 2001b. Applying structured methods to eco-innovation. An evaluation of the product ideas tree diagram. *Design Stud* 22(6), 519-542.
- Jongebreur, A.A., Speelman, L., 1997. Future trends in agricultural engineering. *Neth. J. Agric. Sci.* 45(1), 3-14.
- Joore, P., Brezet, H., 2015. A Multilevel Design Model: The mutual relationship between product-service system development and societal change processes. *Journal of Cleaner Production* 97, 92-105.
- Joore, P., Lindeijer, E., Luiten, H., Rampino, L., Schie, M.V., 2004. SusProNet report. PSS for need area food: An overview, in: Tempelman, E. (Ed.). TNO Industrial Technology, VITO, Centre for Sustainable Design, INETI, Econcept, O2 Global Network.
- Kaab, A., Sharifi, M., Mobli, H., Nabavi-Pelesaraei, A., Chau, K.W., 2019. Combined life cycle assessment and artificial intelligence for prediction of output energy and environmental impacts of sugarcane production. *Sci. Total Environ.* 664, 1005-1019.
- Kandachar, P., 2010. Designing for global sustainable solutions: Challenges and opportunities. *Sustainability in Design: Now*, 60-75.
- Kansanga, M., Andersen, P., Kpienbaareh, D., Mason-Renton, S., Atuoye, K., Sano, Y., Antabe, R., Luginaah, I., 2018. Traditional agriculture in transition: examining the impacts of agricultural modernization on smallholder farming in Ghana under the new Green Revolution. *Int. J. Sustain. Dev. World Ecol.* 26(1), 11-24.
- Kara, S., Manmek, S., Kaebnick, H., 2007. An integrated methodology to estimate the external environmental costs of products. *CIRP annals* 56(1), 9-12.
- Karlsson, R., Luttrupp, C., 2006. EcoDesign: what's happening? An overview of the subject area of EcoDesign and of the papers in this special issue. *Journal of Cleaner Production* 14, 1291-1298.
- Kayastha, P., Rauniyar, G.P., Parker, W., 1999. Determinants of off-farm employment in eastern rural Nepal.
- Kelkar, G., 2007. The feminization of agriculture in Asia: Implications for women's agency and productivity. ASPAC Food & Fertilizer Technology Center.
- Keoleian, G.A., Menerey, D., Curran, M.A., 1993. A life cycle approach to product system design. *POLLUT. PREV. REV.* 3, 293-306.

- Keulen, H.V., van Ittersum, M.K., Leffelaar, P.A., 2005. Multiscale methodological framework to derive criteria and indicators for sustainability evaluation of peasant natural resource management systems. *Environment, development and sustainability* 7(1), 51-69.
- Khalil, C., Conforti, P., Ergin, I., Gennari, P., 2017. Defining small scale food producers to monitor target 2.3 of the 2030 Agenda for Sustainable Development. Food and Agricultural Organization of the United Nations, Rome, Italy.
- Khatun, F., Khan, T.I., Pervin, S., Jahan, H., 2016. Estimating women's contribution to the economy: The case of Bangladesh. *Centre for Policy Dialogue*.
- Khoshnevisan, B., Rajaeifar, M.A., Clark, S., Shamahirband, S., Anuar, N.B., Mohd Shuib, N.L., Gani, A., 2014. Evaluation of traditional and consolidated rice farms in Guilan Province, Iran, using life cycle assessment and fuzzy modeling. *Sci. Total Environ.* 481(1), 242-251.
- Kim, S., Dale, B.E., 2008. Energy and greenhouse gas profiles of polyhydroxybutyrates derived from corn grain: A life cycle perspective. *Environmental Science and Technology* 42(20), 7690-7695.
- Kim, S., Dale, B.E., Keck, P., 2014. Energy Requirements and Greenhouse Gas Emissions of Maize Production in the USA. *Bioenergy Res.* 7(2), 753-764.
- Kobayashi, H., 2005. Strategic evolution of eco-products: A product life cycle planning methodology. *Research in Engineering Design* 16(1-2), 1-16.
- Kobayashi, H., 2006. A systematic approach to eco-innovative product design based on life cycle planning. *Advanced engineering informatics* 20(2), 113-125.
- Kollmann, R., Friebel, F., Neugebauer, G., Narodoslawsky, M., 2016. Process evaluation of the ecological performance of food and energy plant production systems, *Computer Aided Chemical Engineering*, pp. 2187-2192.
- Komatsu, H., Malapit, H.J.L., Theis, S., 2018. Does women's time in domestic work and agriculture affect women's and children's dietary diversity? Evidence from Bangladesh, Nepal, Cambodia, Ghana, and Mozambique. *Food Policy* 79, 256-270.
- Komoto, H., Mishima, N., 2013. Life cycle simulation for sustainable product service systems, *Handbook of Sustainable Engineering*. Springer Netherlands, pp. 633-652.
- Komoto, H., Tomiyama, T., Nagel, M., Silvester, S., Brezet, H., 2005. Life cycle simulation for analyzing product service systems, 4th International Symposium on Environmentally Conscious Design and Inverse Manufacturing, *Eco Design 2005*. Tokyo, pp. 386-393.
- Kondoh, S., Komoto, H., 2013. Eco-business planning: Idea generation method, *Handbook of Sustainable Engineering*. Springer Netherlands, pp. 615-632.
- Krucken, L., Meroni, A., 2006. Building stakeholder networks to develop and deliver product-service-systems: practical experiences on elaborating pro-active materials for communication. *Journal of Cleaner Production* 14(17), 1502-1508.
- Krupnik, T.J., Santos Valle, S., McDonald, A., Justice, S., Hossain, I., Gathala, M.K., 2013. Made in Bangladesh: Scale-appropriate machinery for agricultural resource conservation. *CIMMYT*.
- Krzyżaniak, M., Stolarski, M.J., Warmiński, K., 2018. Life cycle assessment of Virginia mallow production with different fertilisation options. *Journal of Cleaner Production* 177, 824-836.
- Kuo, T.C., 2010. Simulation of purchase or rental decision-making based on product service system. *The International Journal of Advanced Manufacturing Technology* 52(9-12), 1239-1249.
- Kurczewski, P., Lewandowska, A., 2010. ISO 14062 in theory and practice—ecodesign procedure. Part 2: Practical application. *The International Journal of Life Cycle Assessment* 15(8), 777-784.
- Lamb, R.L., 2003. Inverse productivity: Land quality, labor markets, and measurement error. *Journal of Development Economics* 71(1), 71-95.
- Lara-Lopez, A., Chancellor, W., 1999. Tractors: Two-wheel tractors for dry land farming. *CIGR Handbook of Agricultural Engineering* 3, 95-114.
- Lares-Orozco, M.F., Robles-Morúa, A., Yopez, E.A., Handler, R.M., 2016. Global warming potential of intensive wheat production in the Yaqui Valley, Mexico: A resource for the design of localized mitigation strategies. *Journal of Cleaner Production* 127, 522-532.
- Larson, D.F., Otsuka, K., Matsumoto, T., Kilic, T., 2012. Should African rural development strategies depend on smallholder farms? An exploration of the inverse productivity hypothesis. *The World Bank*.
- Le Pochat, S., Bertoluci, G., Froelich, D., 2007. Integrating ecodesign by conducting changes in SMEs. *Journal of Cleaner Production* 15(7), 671-680.
- Lee, H., Jeon, J.B., Park, J., Kim, G., Yoon, S.S., 2012. Developing a combination model of agricultural machine for optimization GHG's based on LCA, *American Society of Agricultural and Biological Engineers Annual International Meeting 2012*. American Society of Agricultural and Biological Engineers, Dallas, TX, pp. 4368-4380.

- Lee, H.M., Lu, W.F., Robert, G.K.L., 2005. An integrated manufacturing and product services system (IMPSS) concept for sustainable product development, 4th International Symposium on Environmentally Conscious Design and Inverse Manufacturing, Eco Design 2005. Tokyo, pp. 656-662.
- Lee, H.M., Lu, W.F., Song, B., Shen, Z., Yang, Z., Gay, R.K.L., 2007. A framework for integrated manufacturing and product service system: Integrating service operations into product life cycle. *International Journal of Services Operations and Informatics* 2(1), 81-101.
- Lee, S., Geum, Y., Lee, H., Park, Y., 2012. Dynamic and multidimensional measurement of product-service system (PSS) sustainability: A triple bottom line (TBL)-based system dynamics approach. *Journal of Cleaner Production* 32, 173-182.
- Lehmann, L.M., Borzęcka, M., Żyłowska, K., Pisanelli, A., Russo, G., Ghaley, B.B., 2020. Environmental impact assessments of integrated food and non-food production systems in Italy and Denmark. *Energies* 13(4).
- Lelah, A., Boucher, X., Moreau, V., Zwolinski, P., 2014. Scenarios as a tool for transition towards sustainable PSS, 6th CIRP Conference on Industrial Product Service Systems, IPSS 2014. Elsevier, Windsor, ON, pp. 122-127.
- Lewandowska, A., Kurczewski, P., 2010. ISO 14062 in theory and practice—ecodesign procedure. Part 1: Structure and theory. *The international journal of life cycle assessment* 15(8), 769-776.
- Li, M., Zhao, L., 2009. Agricultural labor 'aging' phenomenon and its impact on agricultural production—based on empirical analysis of Liaoning Province. *Issues in Agricultural Economy*(10), 12-18.
- Liedtke, C., Baedeker, C., Hasselkuß, M., Rohn, H., Grinewitschus, V., 2015. User-integrated innovation in Sustainable LivingLabs: an experimental infrastructure for researching and developing sustainable product service systems. *Journal of Cleaner Production* 97, 106-116.
- Liedtke, C., Buhl, J., Ameli, N., 2013. Microfoundations for sustainable growth with eco-intelligent product service-arrangements. *Sustainability (Switzerland)* 5(3), 1141-1160.
- Lijó, L., González-García, S., Bacenetti, J., Fiala, M., Feijoo, G., Lema, J.M., Moreira, M.T., 2014. Life cycle assessment of electricity production in Italy from anaerobic co-digestion of pig slurry and energy crops. *Renew. Energy* 68, 625-635.
- Liu, C.H., Chen, M.C., Tu, Y.H., Wang, C.C., 2014. Constructing a sustainable service business model: An S-D logic-based integrated product service system (IPSS). *Int. J. Phys. Distrib. Logist. Manage.* 44(1), 80-97.
- Liu, J., Zang, C., Tian, S., Liu, J., Yang, H., Jia, S., You, L., Liu, B., Zhang, M., 2013. Water conservancy projects in China: Achievements, challenges and way forward. *Global Environmental Change* 23(3), 633-643.
- Liu, Y., Langer, V., Høgh-Jensen, H., Egelyng, H., 2010. Life Cycle Assessment of fossil energy use and greenhouse gas emissions in Chinese pear production. *Journal of Cleaner Production* 18(14), 1423-1430.
- Ljungberg, L.Y., 2007. Materials selection and design for development of sustainable products. *Materials & Design* 28(2), 466-479.
- Lockeretz, W., 1991. Multidisciplinary research and sustainable agriculture. *Biol. Agric. Hortic.* 8(2), 101-122.
- Lofthouse, V., 2006. Ecodesign tools for designers: defining the requirements. *Journal of Cleaner Production* 14(15-16), 1386-1395.
- Longo, S., Mistretta, M., Guarino, F., Cellura, M., 2017. Life Cycle Assessment of organic and conventional apple supply chains in the North of Italy. *Journal of Cleaner Production* 140, 654-663.
- López-Ridaura, S., 2002. Evaluating the sustainability of complex socio-environmental systems. The MESMIS framework. *Ecol Indic* 2(1-2), 135-148.
- Lovarelli, D., Bacenetti, J., 2017a. Bridging the gap between reliable data collection and the environmental impact for mechanised field operations. *Biosyst. Eng.* 160, 109-123.
- Lovarelli, D., Bacenetti, J., 2017b. Seedbed preparation for arable crops: Environmental impact of alternative mechanical solutions. *Soil Tillage Res.* 174, 156-168.
- Lovarelli, D., Bacenetti, J., Fiala, M., 2017. Effect of local conditions and machinery characteristics on the environmental impacts of primary soil tillage. *Journal of Cleaner Production* 140, 479-491.
- Lovarelli, D., Fiala, M., Larsson, G., 2018a. Fuel consumption and exhaust emissions during on-field tractor activity: A possible improving strategy for the environmental load of agricultural mechanisation. *Comput. Electron. Agric.* 151, 238-248.
- Lovarelli, D., Fusi, A., Pretolani, R., Bacenetti, J., 2018b. Delving the environmental impact of roundwood production from poplar plantations. *Sci. Total Environ.* 645, 646-654.
- Lovarelli, D., Garcia, L.R., Sánchez-Girón, V., Bacenetti, J., 2020. Barley production in Spain and Italy: Environmental comparison between different cultivation practices. *Sci. Total Environ.* 707.
- Lowder, S.K., Skoet, J., Raney, T., 2016. The number, size, and distribution of farms, smallholder farms, and family farms worldwide. *World Development* 87, 16-29.

- Lozano, R., Merrill, M.Y., Sammalisto, K., Ceulemans, K., Lozano, F.J., 2017. Connecting competences and pedagogical approaches for sustainable development in higher education: A literature review and framework proposal. *Sustainability* 9(10), 15.
- Luiten, H., Knot, M., Van Der Horst, T., 2001. Sustainable product-service-systems: The Kathalys method, 2nd International Symposium on Environmentally Conscious Design and Inverse Manufacturing, EcoDesign 2001. Institute of Electrical and Electronics Engineers Inc., pp. 190-197.
- Luttropp, C., Lagerstedt, J., 2006. EcoDesign and The Ten Golden Rules: generic advice for merging environmental aspects into product development. *Journal of Cleaner Production* 14(15-16), 1396-1408.
- Ma, J., Kim, H.M., 2014. Predictive usage mining for sustainability of complex systems design, ASME 2014 International Design Engineering Technical Conferences and Computers and Information in Engineering Conference, IDETC/CIE 2014. American Society of Mechanical Engineers (ASME).
- Ma, J., Kim, H.M., 2015. Predictive usage mining for life cycle assessment. *Transportation Research Part D: Transport and Environment* 38, 125-143.
- MacDonald, J.P., 2005. Strategic sustainable development using the ISO 14001 standard. *Journal of Cleaner Production* 13(6), 631-643.
- Maciel, V.G., Zortea, R.B., Menezes Da Silva, W., Cybis, L.F.D.A., Einloft, S., Seferin, M., 2015. Life Cycle Inventory for the agricultural stages of soybean production in the state of Rio Grande do Sul, Brazil. *Journal of Cleaner Production* 93, 65-74.
- Macrae, R.J., Hill, S.B., Mehuys, G.R., Henning, J., 1990. Farm-scale agronomic and economic conversion from conventional to sustainable agriculture. *Advances in Agronomy* 43, 155-198.
- Maisenbacher, S., Weidmann, D., Kasperek, D., Omer, M., 2014. Applicability of agent-based modeling for supporting product-service system development, 6th CIRP Conference on Industrial Product Service Systems, IPSS 2014. Elsevier, Windsor, ON, pp. 356-361.
- Mallaiah, L.C., 2009. Innovation in agriculture and impact on women agricultural workers in india, International Association for Feminist Economics (IAFFE) Annual Conference. Boston, MA, USA.
- Mantoam, E.J., Romanelli, T.L., Gimenez, L.M., Milan, M., 2017. Energy demand and greenhouse gases emissions in the life cycle of coffee harvesters. *Chemical Engineering Transactions* 58, 175-180.
- Manzini, E., Evans, S., Collina, L., 2004. Solution oriented partnership: how to design industrialised sustainable solutions. Cranfield University.
- Marchand, F., Debruyne, L., Triste, L., Gerrard, C., Padel, S., Lauwers, L., 2014. Key characteristics for tool choice in indicator-based sustainability assessment at farm level. *Ecol Soc* 19(3), 10.
- Marosky, N., Dose, J., Fleischer, G., Ackermann, R., 2007. Challenges of data transfer between CAD and LCA software tools, Proceedings of the 3rd International Conference on Life Cycle Management, University of Zurich, Irchel, Switzerland.
- Martinez, V., Leseure, M., Bastl, M., Kingston, J., Evans, S., 2010. Challenges in transforming manufacturing organisations into product-service providers. *Journal of Manufacturing Technology Management* 21(4), 449-469.
- Masters, W.A., Djurfeldt, A.A., De Haan, C., Hazell, P., Jayne, T., Jirström, M., Reardon, T., 2013. Urbanization and farm size in Asia and Africa: Implications for food security and agricultural research. *Global Food Security* 2(3), 156-165.
- Mathieux, F., Froelich, D., Moszkowicz, P., 2008. ReSICLED: A new recovery-conscious design method for complex products based on a multicriteria assessment of the recoverability. *Journal of Cleaner Production* 16(3), 277-298.
- Mathieux, F., Roucoules, L., Lescuyer, L., Bouzidi, Y., 2005. Opportunities and challenges for connecting environmental assessment tools and CAD software, of LCM 2005-Innovation by Life Cycle Management. pp. -.
- Maxwell, D., Sheate, W., van der Vorst, R., 2006. Functional and systems aspects of the sustainable product and service development approach for industry. *Journal of Cleaner Production* 14(17), 1466-1479.
- Maxwell, D., Van der Vorst, R., 2003. Developing sustainable products and services. *Journal of Cleaner Production* 11(8 SPEC.), 883-895.
- McMillan, J.H., 1996. Educational research: Fundamentals for the consumer. ERIC.
- Mebratu, D., 1998. Sustainability and sustainable development: Historical and conceptual review. *Environmental Impact Assessment Review* 18(6), 493-520.
- Mehta, C., Chandel, N., Senthilkumar, T., 2014. Status, challenges and strategies for farm mechanization in India. *Agricultural Mechanization in Asia Africa and Latin America* 45(4), 43-50.
- Mehta, C.R., Chandel, N.S., Senthilkumar, T., Singh, K.K., 2014. Trends of agricultural mechanization in India. *United Nations Economic and Social Commission for Asia and the Pacific*, 1-13.
- Meier, H., Roy, R., Seliger, G., 2010. Industrial product-service systems-IPS2. *CIRP Ann Manuf Technol* 59(2), 607-627.

- Meul, M., Van Passel, S., Nevens, F., Dessein, J., Rogge, E., Mulier, A., Van Hauwermeiren, A., 2008. MOTIFS: A monitoring tool for integrated farm sustainability. *Agron Sustain Dev* 28(2), 321-332.
- Michaelis, L., 2000. Sustainable consumption and production. *Earth Summit 2002*, 264.
- Mimeo, J., Taylor, J., Edward, J., Kagin, A., Yúnez-Naude, Castelhana, M., 2011. The efficiency of smallholders in Mexico's modern agricultural economy. FAO, Rome, Italy. In Rapsomanikis, G., 2015. The economic lives of smallholder farmers - An analysis based on household data from nine countries. Food and Agricultural Organization of the United Nations, Rome, Italy.
- Mont, O., 2001. Introducing and developing a product -service system (PSS) concept in Sweden. Lund University, LUND, Sweden.
- Mont, O., 2004a. Institutionalisation of sustainable consumption patterns based on shared use. *Ecological Economics* 50(1-2), 135-153.
- Mont, O., 2004b. Product-service systems: panacea or myth? Lund University.
- Mont, O., Lindhqvist, T., 2003. The role of public policy in advancement of product service systems. *Journal of Cleaner Production* 11(8), 905-914.
- Morbidoni, A., Favi, C., Germani, M., 2011. CAD-Integrated LCA Tool: Comparison with dedicated LCA Software and Guidelines for the improvement, Globalized solutions for sustainability in manufacturing. Springer, pp. 569-574.
- Morelli, N., 2006. Developing new product service systems (PSS): Methodologies and operational tools. *Journal of Cleaner Production* 14(17), 1495-1501.
- Morgan, M., 1993. Creating workforce innovation: Turning individual creativity into organisational innovation. Business & Professional Publishing.
- Mottaleb, K.A., Krupnik, T.J., Erenstein, O., 2016. Factors associated with small-scale agricultural machinery adoption in Bangladesh: Census findings. *Journal of Rural Studies* 46, 155-168.
- Mottaleb, K.A., Rahut, D.B., Ali, A., Gérard, B., Erenstein, O., 2017. Enhancing smallholder access to agricultural machinery services: lessons from Bangladesh. *The journal of development studies* 53(9), 1502-1517.
- Mourtzis, D., Fotia, S., Doukas, M., 2015. Performance indicators for the evaluation of product-service systems design: A review, in: Umeda, S., Mizuyama, H., Hibino, H., von Cieminski, G., Kiritsis, D., Nakano, M. (Eds.), IFIP WG 5.7 International Conference on Advances in Production Management Systems, APMS 2015. Springer New York LLC, pp. 592-601.
- Mrema, G., Soni, P., Rolle, R., 2014. A regional strategy for sustainable agricultural mechanization: Sustainable mechanization across agri-food chains in Asia and the Pacific region. RAP Publication(2014/24).
- Murray, J., Tullberg, J.N., Basnet, B., 2006. Planters and their components: Types, attributes, functional requirements, classification and description (ACIAR Monograph No. 121).
- Mylan, J., 2015. Understanding the diffusion of Sustainable Product-Service Systems: Insights from the sociology of consumption and practice theory. *Journal of Cleaner Production* 97, 13-20.
- NABARD, NABARD - power tiller. <https://www.nabard.org/english/powertiller.aspx>.
- Nagayets, O., 2005. Small farms: Current status and key trends. *The future of small farms* 355.
- Nalley, L.L., Danforth, D.M., Niederman, Z., Teague, T.G., 2013. A scan level cotton carbon life cycle assessment: Has bio-tech reduced the carbon emissions from cotton production in the USA? *J. Cotton Sci.* 17(2), 80-88.
- Narang, S., Tiwari, P., 2004. Power tiller use in selected villages in West Bengal and Assam-a success story. *Agricultural Engineering Today* 28(3and4), 42-47.
- Natural Resources Management and Environment Department, Food and Agriculture Organization of the United Nations, 2012. Sustainability Assessment of Food and Agriculture Systems (SAFA) Guidelines (Draft 4.0 – compact version).
- Naylor, R., Steinfeld, H., Falcon, W., Galloway, J., Smil, V., Bradford, E., Alder, J., Mooney, H., 2005. Agriculture. Losing the links between livestock and land. *Science* 310(5754), 1621-1622.
- Ntiamoah, A., Afrane, G., 2008. Environmental impacts of cocoa production and processing in Ghana: Life cycle assessment approach. *Journal of Cleaner Production* 16(16), 1735-1740.
- Nunamaker Jr, J.F., Chen, M., Purdin, T.D., 1990. Systems development in information systems research. *Journal of management information systems* 7(3), 89-106.
- Nunes, F.A., Seferin, M., Maciel, V.G., Ayub, M.A.Z., 2017. Life Cycle Assessment comparison between brown parboiled rice produced under organic and minimal tillage cultivation systems. *Journal of Cleaner Production* 161, 95-104.
- Nunes, F.A., Seferin, M., Maciel, V.G., Flôres, S.H., Ayub, M.A.Z., 2016. Life cycle greenhouse gas emissions from rice production systems in Brazil: A comparison between minimal tillage and organic farming. *Journal of Cleaner Production* 139, 799-809.

- Ny, H., Hallstedt, S., Ericson, A., 2013. A strategic approach for sustainable product service system development, 22nd CIRP Design Conference, CIRP Design 2012. Springer-Verlag London Ltd, Bangalore, pp. 427-436.
- Ogle, S.M., Breidt, F.J., Paustian, K., 2005. Agricultural management impacts on soil organic carbon storage under moist and dry climatic conditions of temperate and tropical regions. *Biogeochemistry* 72(1), 87-121.
- Ogunjirin, O.C., Jekayinfa, S.O., Olaniran, J.A., Ogunjirin, O.A., 2020. Environmental life cycle assessment of cowpea production, storage and disposal in Ilorin, Kwara State, Nigeria, 40th Conference of Nigerian Institution of Agricultural Engineers, NIAE 2019, 1 ed. Institute of Physics Publishing.
- Organization, W.H., ExpandNet, 2011. Beginning with the end in mind: Planning pilot projects and other programmatic research for successful scaling up. World Health Organization, France.
- Palmieri, N., Forleo, M.B., Suardi, A., Coaloa, D., Pari, L., 2014. Rapeseed for energy production: Environmental impacts and cultivation methods. *Biomass Bioenergy* 69, 1-11.
- Pan, J.N., Nguyen, H.T.N., 2015. Achieving customer satisfaction through product-service systems. *Eur J Oper Res* 247(1), 179-190.
- Pandey, A., Gaur, R.K., 2007. Emerging trends in production and sale of tractor and power tiller in India. *The Allahabad Farmer Journal* 63, 20.
- Pandey, M.M., 2008. Mechanization of hill agriculture, *Agricultural Mechanization Technologies for North East India*, Division Of Agricultural Engineering, ICAR Research Complex for NEH Region, Umiam, Meghalaya, India.
- Paramesh, V., Arunachalam, V., Nikkiah, A., Das, B., Ghnimi, S., 2018. Optimization of energy consumption and environmental impacts of arecanut production through coupled data envelopment analysis and life cycle assessment. *Journal of Cleaner Production* 203, 674-684.
- Park, H., Yoon, J., 2013. A chance discovery-based approach for new product-service system (PSS) concepts. *Serv. Bus.* 9(1), 115-135.
- Park, J., Seaton, R.A.F., 1996. Integrative research and sustainable agriculture. *Agricultural Systems* 50(1), 81-100.
- Park, P.J., Tahara, K., 2008. Quantifying producer and consumer-based eco-efficiencies for the identification of key ecodesign issues. *Journal of Cleaner Production* 16(1), 95-104.
- Paudel, G.P., Kc, D.B., Rahut, D.B., Khanal, N.P., Justice, S.E., McDonald, A.J., 2019. Smallholder farmers' willingness to pay for scale-appropriate farm mechanization: Evidence from the mid-hills of Nepal. *Technol Soc* 59, 101196.
- Peffer, K., Tuunanen, T., Gengler, C.E., Rossi, M., Hui, W., Virtanen, V., Bragge, J., 2006. The design science research process: A model for producing and presenting information systems research, *Proceedings of the first international conference on design science research in information systems and technology (DESRIST 2006)*. ME Sharpe, Inc., pp. 83-106.
- Peffer, K., Tuunanen, T., Rothenberger, M.A., Chatterjee, S., 2007. A design science research methodology for Information Systems Research. *Journal of Management Information Systems* 24(3), 45-77.
- Perić, M., Komatina, M., Antonijević, D., Bugarski, B., Dželetović, Ž., 2018. Life cycle impact assessment of Miscanthus crop for sustainable household heating in Serbia. *Forests* 9(10).
- Peruzzini, M., Germani, M., Marilungo, E., 2013a. Design for sustainability of product-service systems in the extended enterprise, 20th ISPE International Conference on Concurrent Engineering, CE 2013. Melbourne, VIC, pp. 314-323.
- Peruzzini, M., Germani, M., Marilungo, E., 2013b. Product-service sustainability assessment in Virtual Manufacturing Enterprises, 14th IFIP WG 5.5 Working Conference on Virtual Enterprises, PRO-VE 2013. Springer New York LLC, Dresden, pp. 13-21.
- Peruzzini, M., Germani, M., Marilungo, E., 2013c. A sustainability lifecycle assessment of products and services for the extended enterprise evolution, in: Bernard, A., Rivest, L., Dutta, D. (Eds.), 10th IFIP WG 5.1 International Conference on Product Lifecycle Management for Society, PLM 2013. Springer New York LLC, pp. 100-109.
- Peruzzini, M., Marilungo, E., Germani, M., 2014. A QFD-based methodology to support Product-Service design in manufacturing industry, 2014 International Conference on Engineering, Technology and Innovation, ICE 2014. IEEE Computer Society, Bergamo.
- Peruzzini, M., Marilungo, E., Germani, M., 2015. Structured requirements elicitation for product-service system. *International Journal of Agile Systems and Management* 8(3-4), 189-218.
- Pialot, O., Millet, D., Cor, E., Bisiaux, J., 2015. A method helping to define eco-innovative systems based on upgradability, in: Brissaud, D., Boucher, X. (Eds.), 7th CIRP Industrial Product-Service Systems Conference, IPSS 2015. Elsevier B.V., pp. 185-190.
- Pigosso, D.C., Rozenfeld, H., McAlloone, T.C., 2013. Ecodesign maturity model: a management framework to support ecodesign implementation into manufacturing companies. *Journal of Cleaner Production* 59, 160-173.

- Pigosso, D.C.A., McAloone, T.C., 2015. Supporting the development of environmentally sustainable PSS by means of the ecodesign maturity model, in: Brissaud, D., Boucher, X. (Eds.), 7th CIRP Industrial Product-Service Systems Conference, IPSS 2015. Elsevier B.V., pp. 173-178.
- Pingali, P., Bigot, Y., Binswanger, H.P., 1987. Agricultural mechanization and the evolution of farming systems in Sub-Saharan Africa. World Bank.
- Pingali, P.L., Rosegrant, M.W., 1995. Agricultural commercialization and diversification: Processes and policies. *Food policy* 20(3), 171-185.
- Plomp, T., Nieveen, N., 2013. Educational design research: Introduction and illustrative cases. Enschede: SLO. Online: [http://www.international.slo.nl/edr/\(12.04.2016\)](http://www.international.slo.nl/edr/(12.04.2016)). In Reubens, R. (2016). "To craft, by design, for sustainability: Towards holistic sustainability design for developing-country enterprises."
- Poats, S.V., 1991. To role of gender in agricultural development. Consultative Group on International Agricultural Research, Issues in Agriculture, Washington, D.C.: The World Bank, p. 69.
- Pope, R.D., Prescott, R., 1980. Diversification in relation to farm size and other socioeconomic characteristics. *American Journal of Agricultural Economics* 62(3), 554-559.
- Pottiez, E., Lescoat, P., Bouvare, I., 2012. AVIBIO: a method to assess the sustainability of the organic poultry industry, Proceedings of the 10th European International Farming Systems Association (IFSA) Symposium.
- Pradel, M., Pacaud, T., Cariolle, M., 2013. Valorization of organic wastes through agricultural fertilization: Coupling models to assess the effects of spreader performances on nitrogenous emissions and related environmental impacts. *Waste Biomass Valoris.* 4(4), 851-872.
- Pradhan, A., Shrestha, D.S., McAloon, A., Yee, W., Haas, M., Duffield, J.A., 2011. Energy life-cycle assessment of soybean biodiesel revisited. *Trans. ASABE* 54(3), 1031-1039.
- Pray, C., 2013. Discussant's comments at the ISPC Foresight Study Workshop on trends in urbanization and farm size in Sub-Saharan Africa and South Asia: Implications for agricultural research, 25–26 January 2013. Tufts University in Boston, USA. pray@aesop.rutgers.edu. In Masters, W.A., Djurfeldt, A.A., De Haan, C., Hazell, P., Jayne, T., Jirström, M., Reardon, T., 2013. Urbanization and farm size in Asia and Africa: Implications for food security and agricultural research. *Global Food Security* 2(3), 156-165.
- Pretty, J., Smith, G., Goulding, K.W.T., Groves, S.J., Henderson, I., Hine, R.E., King, V., van Oostrum, J., Pendlington, D.J., Vis, J.K., Walter, C., 2011. Multi-year assessment of Unilever's progress towards agricultural sustainability I: Indicators, methodology and pilot farm results. *International Journal of Agricultural Sustainability* 6(1), 37-62.
- Proto, A.R., Bacenetti, J., Macrì, G., Fiala, M., Zimbalatti, G., 2017. Mechanisation of different logging operations: Environmental impact assessment using life cycle assessment (LCA) approach. *Chemical Engineering Transactions* 58, 229-234.
- Pryor, S.W., Smithers, J., Lyne, P., van Antwerpen, R., 2017. Impact of agricultural practices on energy use and greenhouse gas emissions for South African sugarcane production. *Journal of Cleaner Production* 141, 137-145.
- Radjou, N., 2009. Polycentric innovation: A new mandate for multinationals. *The Wall Street Journal*. In Biggs, S., Justice, S., Lewis, D., 2011. Patterns of rural mechanisation, energy and employment in South Asia: reopening the debate. *Economic and Political Weekly*, 78-82. 9.
- Ranganathan, T., 2015. Farmers' income in India: Evidence from secondary data - A study submitted to ministry of agriculture. Agricultural Economics Research Unit, Institute of Economic Growth, New Delhi, p. 89.
- Rapsomanikis, G., 2015. The economic lives of smallholder farmers - An analysis based on household data from nine countries. Food and Agricultural Organization of the United Nations, Rome, Italy.
- Rasouli, M.R., Trienekens, J.J.M., Kusters, R.J., Grefen, P.W.P.J., 2015. A dynamic capabilities perspective on service-orientation in Demand-Supply Chains, in: Brissaud, D., Boucher, X. (Eds.), 7th CIRP Industrial Product-Service Systems Conference, IPSS 2015. Elsevier B.V., pp. 396-401.
- Reap, J., Roman, F., Duncan, S., Bras, B., 2008. A survey of unresolved problems in life cycle assessment. *The International Journal of Life Cycle Assessment* 13(5), 374-388.
- Reardon, T., 2013. The economics of urbanization, farm technology, and farm size distribution in Asia. Background Paper for the ISPC Foresight Study on Farm Size and Urbanization. In Masters, W.A., Djurfeldt, A.A., De Haan, C., Hazell, P., Jayne, T., Jirström, M., Reardon, T., 2013. Urbanization and farm size in Asia and Africa: Implications for food security and agricultural research. *Global Food Security* 2(3), 156-165.
- Reardon, T., Barrett, C.B., Berdegue, J.A., Swinnen, J.F.M., 2009. Agrifood industry transformation and small farmers in developing countries. *World Development* 37(11), 1717-1727.
- Reid, J.F., 2011. The impact of mechanization on agriculture. *Bridge* 41(3), 22-29.
- Reim, W., Parida, V., Ortqvist, D., 2015. Product-Service Systems (PSS) business models and tactics - a systematic literature review. *Journal of Cleaner Production* 97, 61-75.

- Renpu, B., 2014. Analysis of the trends of agricultural mechanization development in China (2000-2020). ESCAP/CSAM Policy Brief(1), 9.
- Reubens, R., 2016. To craft, by design, for sustainability: Towards holistic sustainability design for developing-country enterprises.
- Ribeiro, V.C., Borsato, M., 2014. Integrating product-service system tools into new product development processes. *J. Integr. Des. Process Sci.* 18(3), 3-18.
- Ricciardi, V., Ramankutty, N., Mehrabi, Z., Jarvis, L., Chookolingo, B., 2018. How much of the world's food do smallholders produce? *Global Food Security* 17, 64-72.
- Rigby, D., Woodhouse, P., Young, T., Burton, M., 2001. Constructing a farm level indicator of sustainable agricultural practice. *Ecological Economics* 39(3), 463-478.
- Rinaldi, S., Barbanera, M., Lascaro, E., 2014. Assessment of carbon footprint and energy performance of the extra virgin olive oil chain in Umbria, Italy. *Sci. Total Environ.* 482-483(1), 71-79.
- Rocchi, S., 2005. Enhancing sustainable innovation by design. An approach to the co-creation of economic, social and environmental value. Erasmus University Rotterdam, Rotterdam.
- Rodriguez, E., Boks, C., 2005. How design of products affects user behaviour and vice versa: The environmental implications, 2005 4th International Symposium on Environmentally Conscious Design and Inverse Manufacturing. IEEE, pp. 54-61.
- Romanelli, T.L., Milan, M., 2012. Machinery management as an environmental tool - Material embodiment in agriculture. *Agric. Eng. Int. CIGR J.* 14(1), 63-73.
- Rondini, A., Tornese, F., Gnoni, M.G., Pezzotta, G., Pinto, R., 2014. Comparing simulation approaches for designing sustainable PSS, 19th Summer School Francesco Turco 2014. AIDI - Italian Association of Industrial Operations Professors, pp. 108-113.
- Rondini, A., Tornese, F., Gnoni, M.G., Pezzotta, G., Pinto, R., 2015. Business process simulation for the design of sustainable product service systems (PSS), in: Mizuyama, H., Hibino, H., Kiritsis, D., Umeda, S., von Cieminski, G., Nakano, M. (Eds.), IFIP WG 5.7 International Conference on Advances in Production Management Systems, APMS 2015. Springer New York LLC, pp. 646-653.
- Rose, C.M., 2000. Design for environment: A method for formulating product end-of-life strategies. Stanford University Stanford, CA, USA.
- Rosegrant, M.W., Koo, J., Cenacchi, N., Ringler, C., Robertson, R.D., Fisher, M., Cox, C.M., Garrett, K., Perez, N.D., Sabbagh, P., 2014. Food security in a world of natural resource scarcity: The role of agricultural technologies. International Food Policy Research Institute (IFPRI), Washington, D.C.
- Rossi, M., Germani, M., Zamagni, A., 2016. Review of ecodesign methods and tools. Barriers and strategies for an effective implementation in industrial companies. *Journal of Cleaner Production* 129, 361-373.
- Roy, A.D., Shah, T., 2002. Socio-ecology of groundwater irrigation in India. Intensive use of groundwater challenges and opportunities, 307-335.
- Russo, D., Bersano, G., Birolini, V., Uhl, R., 2011. European testing of the efficiency of TRIZ in eco-innovation projects for manufacturing SMEs, ETRIA Triz Future Conference 2010, 3-5 November 2010, Bergamo (Italy). Elsevier Science, pp. 157-171.
- Ryan, C., 2003. Learning from a decade (or so) of eco-design experience. *Journal of Industrial Ecology* 7, 10-12.
- Ryan, C., Fleming, D., 2004. Digital eco-sense: Sustainability and ICT-a new terrain for innovation.
- S. Cortesi, S., Vezzoli, C., Donghi, C., 2010. Case study of the design of eco-efficient product-service-system for KONE Corporation, using the MSDS method and tools, *Sustainability in Design: Now! - Challenges and Opportunities for Design Research, Education and Practice in the XXI Century*. Bangalore (India), pp. 1201-1211.
- Sahed, K., Flora, B., Islam, M., 2017. A review on feminization of agriculture and women empowerment in Bangladesh. *Fundamental and Applied Agriculture* 2(1), 183-188.
- Samberg, L.H., Gerber, J.S., Ramankutty, N., Herrero, M., West, P.C., 2016. Subnational distribution of average farm size and smallholder contributions to global food production. *Environmental Research Letters* 11(12).
- San Miguel, G., Corona, B., Ruiz, D., Landholm, D., Laina, R., Tolosana, E., Sixto, H., Cañellas, I., 2015. Environmental, energy and economic analysis of a biomass supply chain based on a poplar short rotation coppice in Spain. *Journal of Cleaner Production* 94, 93-101.
- Sangha, K.K., 2013. A holistic approach to assess the costs and benefits of modern agriculture system in Punjab, India and some solutions. *Applied Ecology and Environmental Sciences* 1(5), 67-74.
- Santos, A.d., Sampaio, C.P., Silva, J.S.G.d., Costa, J.d., 2014. Assessing the use of Product-Service Systems as a strategy to foster sustainability in an emerging context. *Product Management & Development* 12(2), 99-113.
- Santos dos, A., 2008. Strategies of change towards sustainability: The South American experience, Cipolla, C. and Peruccio, P.P. (eds.) *Changing the Change: Design, visions, proposals and tools Conference Proceedings*, Turin, Italy, 10-12 July 2008 (Torino: Umberto Allemandi & C.).

- Sawhney, M., Balasubramanian, S., Krishnan, V.V., 2003. Creating growth with services. MIT Sloan management review 45(2), 34-44.
- Schader, C., Grenz, J., Meier, M.S., Stolze, M., 2014. Scope and precision of sustainability assessment approaches to food systems. *Ecol Soc* 19(3), 15.
- Scopel, E., Findeling, A., Guerra, E.C., Corbeels, M., 2005. Impact of direct sowing mulch-based cropping systems on soil carbon, soil erosion and maize yield. *Agron Sustain Dev* 25(4), 425-432.
- Sedik, D., Lerman, Z., 2008. Land reform, transition, and rural development. in Lowder, S.K., Skoet, J., Raney, T., 2016. The Number, Size, and Distribution of Farms, Smallholder Farms, and Family Farms Worldwide. *World Development* 87, 16-29. *Development & Transition* no 11.
- Seymour, G., 2017. Women's empowerment in agriculture: Implications for technical efficiency in rural Bangladesh. *Agric. Econ.* 48(4), 513-522.
- Shah, A., 2007. Environmental implications of agriculture and policy initiatives in India and the EU: Review of evidence and issues. Institute of Economic Growth, New Delhi IEG Working Paper Series No. E/277/2007.
- Shah, T., Singh, O.P., Mukherji, A., 2006. Some aspects of South Asia's groundwater irrigation economy: Analyses from a survey in India, Pakistan, Nepal Terai and Bangladesh. *Hydrogeology Journal* 14(3), 286-309.
- Sharma, A., 2007. The changing agricultural demography of India: Evidence from a rural youth perception survey. *International Journal of Rural Management* 3(1), 27-41.
- Shepherd, A., Kayunze, K., 2011. Hidden hunger in rural Tanzania: What can qualitative research tell us about what to do about chronic food insecurity? Available at SSRN 1896166.
- Shokohyar, S., Mansour, S., Karimi, B., 2014. A model for integrating services and product EOL management in sustainable product service system (S-PSS). *J Intell Manuf* 25(3), 427-440.
- Sidhu, R.S., Johl, S.S., 2002. Three decades of intensive agriculture in Punjab: Socio-economic and environmental consequences. *Future of Agriculture in Punjab*, Chandigarh: CRRID Publishers.
- Sidhu, R.S., Vatta, K., Dhaliwal, H.S., 2010. Conservation agriculture in Punjab—economic implications of technologies and practices. *Indian Journal of Agricultural Economics* 65, 413.
- Sims, B., Kahan, D., Mpagalile, J., Hilmi, M., Santos Valle, S., 2018. Hire services as a business enterprise: A training manual for small-scale mechanization service providers. FAO.
- Sims, B., Kienzle, J., 2015. Mechanization of conservation agriculture for smallholders: Issues and options for sustainable intensification. *Environments* 2(4), 139-166.
- Sims, B., Kienzle, J., 2016. Making mechanization accessible to smallholder farmers in sub-Saharan Africa. *Environments* 3(4).
- Sims, B., Kienzle, J., 2017. Sustainable agricultural mechanization for smallholders: What is it and how can we implement it? *Agriculture* 7(6).
- Sims, B.G., Hilmi, M., Kienzle, J., 2016. Agricultural mechanization: A key input for sub-Saharan Africa smallholders. *Integrated Crop Management (FAO) eng v. 23* (2016).
- Sims, B.G., Kienzle, J., 2006. Farm power and mechanization for small farms in sub-Saharan Africa, Agricultural and food engineering technical report. Food and Agricultural Organization of the United Nations, Rome, Italy.
- Sims, B.G., Kienzle, J., 2009. Farm equipment supply chains-guidelines for policy-makers and service providers: Experiences from Kenya, Pakistan and Brazil. *Technical Report-Agricultural and Food Engineering*(7).
- Sims, B.G., Thierfelder, C., Kienzle, J., Friedrich, T., Kassam, A., 2012. Development of the conservation agriculture equipment industry in sub-Saharan Africa. *Appl Eng Agric* 28(6), 813-823.
- Singh, G., 2006. Agricultural Machinery Industry in India (Manufacturing, marketing and mechanization promotion). *Status of Farm Mechanization in India*, 154-174.
- Singh, J., Sidhu, R.S., 2006. Accounting for impact of environmental degradation in agriculture of Indian Punjab. 19, 37-48.
- Singh, R., Kumar, P., Woodhead, T., 2002. Smallholder farmers in India: Food security and agricultural policy. RAP publication, Bangkok, Thailand.
- Singh, S., 2009. Agricultural machinery industry in India: A study of growth, market structure, and business strategies. *Growth* 8(9), 10.
- Singh, S., 2010. *Agricultural machinery industry in India*. Allied Publishers.
- Smyth, A.J., Dumanski, J., Spendjian, G., Swift, M.J., 1993. FESLM: An international framework for evaluating sustainable land management. FAO Rome.
- Sonderegger, T., Pfister, S., Hellweg, S., 2020. Assessing impacts on the natural resource soil in life cycle assessment: Methods for compaction and water erosion. *Environmental Science and Technology* 54(11), 6496-6507.
- Soumitri, V., Vezzoli, C., 2002. Product service system design: Sustainable opportunities for all. A design research working hypothesis. Clothing care system for Kumaon Hostel at IIT Delhi, Ecodesign international conference. New Delhi, India.

- Stoessel, F., Juraske, R., Pfister, S., Hellweg, S., 2012. Life cycle inventory and carbon and water footprint of fruits and vegetables: Application to a swiss retailer. *Environmental Science and Technology* 46(6), 3253-3262.
- Sun, J., Han, B., Ekwaro-Osire, S., Zhang, H.-C., 2003. Design for environment: Methodologies, tools, and implementation. *Journal of Integrated Design & Process Science* 7, 59-75.
- Sundin, E., 2001. Enhanced product design facilitating remanufacturing of two household appliances: A case study.
- Sundin, E., 2004. Product and process design for successful remanufacturing. Linköping University Electronic Press.
- Sundin, E., Nässlander, E., Lelah, A., 2015. Sustainability indicators for small and medium-sized enterprises (SMEs) in the transition to provide Product-Service Systems (PSS), in: Brissaud, D., Boucher, X. (Eds.), 7th CIRP Industrial Product-Service Systems Conference, IPSS 2015. Elsevier B.V., pp. 149-154.
- Tabatabaie, S.M.H., Bolte, J.P., Murthy, G.S., 2018. A regional scale modeling framework combining biogeochemical model with life cycle and economic analysis for integrated assessment of cropping systems. *Sci. Total Environ.* 625, 428-439.
- Tabatabaie, S.M.H., Murthy, G.S., 2016. Cradle to farm gate life cycle assessment of strawberry production in the United States. *Journal of Cleaner Production* 127, 548-554.
- Tabatabaie, S.M.H., Tahami, H., Murthy, G.S., 2016. A regional life cycle assessment and economic analysis of camelina biodiesel production in the Pacific Northwestern US. *Journal of Cleaner Production* 172, 2389-2400.
- Takele, A., Selassie, Y.G., Yildiz, F., 2018. Socio-economic analysis of conditions for adoption of tractor hiring services among smallholder farmers, Northwestern Ethiopia. *Cogent Food & Agriculture* 4(1).
- Tang, J., MacLeod, C., 2006. Labour force ageing and productivity performance in Canada. *Canadian Journal of Economics/Revue canadienne d'économie* 39(2), 582-603.
- Tasaki, T., Hashimoto, S., Moriguchi, Y., 2006. A quantitative method to evaluate the level of material use in lease/reuse systems of electrical and electronic equipment. *Journal of Cleaner Production* 14(17), 1519-1528.
- Tassielli, G., Renzulli, P.A., Mousavi-Avval, S.H., Notarnicola, B., 2019. Quantifying life cycle inventories of agricultural field operations by considering different operational parameters. *Int. J. Life Cycle Assess.* 24(6), 1075-1092.
- The Economist Intelligence Unit, 2018. Global Food Security Index - 2018 - building resilience in the face of rising food-security risks p. 49.
- The World Bank Group, 2020a. Agriculture, forestry, and fishing, value added (% of GDP) - World Bank national accounts data, and OECD National Accounts data files, 2020 ed. The World Bank Group.
- The World Bank Group, 2020b. World Bank country and lending groups. <https://datahelpdesk.worldbank.org/knowledgebase/articles/906519-world-bank-country-and-lending-groups>. (Accessed 7 August 2020).
- Thornhill, I., Ho, J.G., Zhang, Y., Li, H., Ho, K.C., Miguel-Chinchilla, L., Loiselle, S.A., 2017. Prioritising local action for water quality improvement using citizen science; a study across three major metropolitan areas of China. *Sci Total Environ* 584-585, 1268-1281.
- Throne-Holst, H., Stø, E., Strandbakken, P., 2007. The role of consumption and consumers in zero emission strategies. *Journal of Cleaner Production* 15(13-14), 1328-1336.
- Tingström, J., Karlsson, R., 2006. The relationship between environmental analyses and the dialogue process in product development. *Journal of Cleaner Production* 14(15-16), 1409-1419.
- Tischner, U., Verkuijl, M., 2002. Sustainable product-service co-design network-first draft report. SusProNet, Web: www.suspronet.org.
- Tischner, U., Vezzoli, C., 2009a. D4S Global Guide - Worksheets Product Service Systems, in: Crul, M., Diehl, J.C., Ryan, C. (Eds.), *Design for Sustainability (D4S): A Step-By-Step Approach*. United Nations Environment Program (UNEP).
- Tischner, U., Vezzoli, C., 2009b. Product-service systems: Tools and cases, in: Crul, M., Diehl, J.C., Ryan, C. (Eds.), *Design for Sustainability (D4S): A Step-By-Step Approach*. United Nations Environment Program (UNEP).
- Tiwari, P., Varshney, A., 1997. Power tillers in India- prospects and future role. *Productivity* 38, 141-148.
- Todde, G., Murgia, L., Caria, M., Pazzona, A., 2018. A Comprehensive energy analysis and related carbon footprint of dairy farms, Part 2: Investigation and modeling of indirect energy requirements. *Energies* 11(2).
- Tonelli, F., Taticchi, P., Starnini, E., 2009. A framework for evaluating product-service systems strategies, WSEAS International Conference. Proceedings. Recent Advances in Computer Engineering. WSEAS.
- Tubiello, F., Córdor-Golec, R., Salvatore, M., Piersante, A., Federici, S., Ferrara, A., Rossi, S., Flammini, A., Cardenas, P., Biancalani, R., 2015. Estimating greenhouse gas emissions in agriculture: A manual to address data requirements for developing countries. *Estimating greenhouse gas emissions in agriculture: a manual to address data requirements for developing countries*.

- Tukker, A., 2004. Eight types of product-service system: eight ways to sustainability? Experiences from SusProNet. *Bus. Strat. Env.* 13(4), 246-260.
- Tukker, A., Tischner, U., 2006. *New business for old Europe. Product services, sustainability and competitiveness.* Sheffield, UK: Greenleaf Publishing Ltd.
- Tukker, A., Tischner, U., 2006. Product-services as a research field: Past, present and future. Reflections from a decade of research. *Journal of Cleaner Production* 14(17), 1552-1556.
- Tzilivakis, J., Lewis, K.A., 2004. The development and use of farm-level indicators in England. *Sustainable development* 12(2), 107-120.
- UNEP, 2002. *Product-service systems and sustainability. Opportunities for sustainable solutions.* UNEP, Division of Technology Industry and Economics, Production and Consumption Branch, Paris, France.
- UNEP, IUCN, WWF For Nature, 1991. *The caring for the earth: A strategy for sustainable living* IUCN Publication.
- United Nations, 2000. *United Nations Millennium Declaration.* p. 9.
- United Nations, 2001. *Indicators of sustainable development: Guidelines and methodologies.* United Nations Department of Economic and Social Affairs, Division for Sustainable Development, New York.
- United Nations, 2012. *The Future We Want: Outcome document adopted at Rio+20 Conference on Sustainable Development.* Rio+20 United Nations Conference on Sustainable Development, 1-49.
- United Nations, 2020. *World economic situation and prospects 2020.* United Nations, New York.
- United Nations, Department of Economic and Social Affairs, Population Division, 2019. *World population prospects 2019, custom data acquired via website.*
- Vagnoni, E., Franca, A., Breedveld, L., Porqueddu, C., Ferrara, R., Duce, P., 2015. Environmental performances of Sardinian dairy sheep production systems at different input levels. *Sci. Total Environ.* 502, 354-361.
- van Calker, K.J., Berentsen, P.B.M., de Boer, I.J.M., Giesen, G.W.J., Huirne, R.B.M., 2007. Modelling worker physical health and societal sustainability at farm level: An application to conventional and organic dairy farming. *Agricultural Systems* 94(2), 205-219.
- Van Calker, K.J., Berentsen, P.B.M., Romero, C., Giesen, G.W.J., Huirne, R.B.M., 2006. Development and application of a multi-attribute sustainability function for Dutch dairy farming systems. *Ecological Economics* 57(4), 640-658.
- Van Cauwenbergh, N., Biala, K., Biolders, C., Brouckaert, V., Franchois, L., Garcia Ciudad, V., Hermy, M., Mathijs, E., Muys, B., Reijnders, J., Sauvenier, X., Valckx, J., Vanclooster, M., Van der Veken, B., Wauters, E., Peeters, A., 2007. SAFE—A hierarchical framework for assessing the sustainability of agricultural systems. *Agriculture, Ecosystems & Environment* 120(2-4), 229-242.
- Van den Akker, J., 1999. Principles and methods of development research, Design approaches and tools in education and training. Springer, pp. 1-14.
- Van Halen, C., Vezzoli, C., Wimmer, R., 2005. *Methodology for product service system innovation: How to develop clean, clever and competitive strategies in companies.* Uitgeverij Van Gorcum.
- Van Hemel, C.G., 2001. *Design for environment in practice: Three dutch industrial approaches compared.*
- Van Linden, V., Herman, L., 2014. A fuel consumption model for off-road use of mobile machinery in agriculture. *Energy* 77, 880-889.
- Van Loon, J., Baudron, F., Krupnik, T., 2015. A round tour of mechanisation. *Rural 21 - The international Journal for Rural Development.*
- Van Loon, J., Speratti, A., Gabarra, L., Govaerts, B., 2018. Precision for smallholder farmers: A small-scale-tailored variable rate fertilizer application kit. *Agriculture* 8(4).
- Van Loon, J., Woltering, L., Krupnik, T.J., Baudron, F., Boa, M., Govaerts, B., 2020. Scaling agricultural mechanization services in smallholder farming systems: Case studies from sub-Saharan Africa, South Asia, and Latin America. *Agric. Syst.* 180, 102792.
- Van Nes, N., Cramer, J., 2006. Product lifetime optimization: A challenging strategy towards more sustainable consumption patterns. *Journal of Cleaner Production* 14, 1307-1318.
- Veiga, J.P.S., Malik, A., Lenzen, M., Ferreira Filho, J.B.D.S., Romanelli, T.L., 2018. Triple-bottom-line assessment of São Paulo state's sugarcane production based on a Brazilian multi-regional input-output matrix. *Renewable Sustainable Energy Rev* 82, 666-680.
- Veisi, H., 2012. Exploring the determinants of adoption behaviour of clean technologies in agriculture: A case of integrated pest management. *Asian J. Technol. Innov.* 20(1), 67-82.
- Velamuri, V.K., Neyer, A.-K., Möslin, K.M., 2011. Hybrid value creation: A systematic review of an evolving research area. *Journal für Betriebswirtschaft* 61(1), 3-35.
- Venable, J., 2006. A framework for design science research activities, *Emerging Trends and Challenges in Information Technology Management: Proceedings of the 2006 Information Resource Management Association Conference.* Idea Group Publishing, pp. 184-187.

- Venugopal, P., 2004. State of the Indian farmer: A millennium study. Input management. Department of Agriculture and Cooperation, Ministry of Agriculture, Government of India.
- Vergragt, P., Green, K., 2007. The SusHouse methodology. Design orienting scenarios for sustainable solutions. *Management* 5(2), 1-16.
- Vezzoli, C., Ceschin, F., 2009. Sustainable scenarios for upstream waste reduction in the food chain, *Food Science Research and Technology*. Nova Science Publishers, New York, pp. 65-110.
- Vezzoli, C., Ceschin, F., Diehl, J.C., Kohtala, C., 2015. New design challenges to widely implement 'Sustainable Product-Service Systems'. *Journal of Cleaner Production* 97, 1-12.
- Vezzoli, C.A., Kohtala, C., Srinivasan, A., Xin, L., Fusakul, M., Sateesh, D., Diehl, J.C., 2014. Product-service system design for sustainability. Greenleaf Publishing.
- Vezzoli, C.A., Manzini, E., 2008. Design for environmental sustainability. Springer Science & Business Media.
- Vieri, M., Sarri, D., 2010. Criteria for introducing mechanical harvesting of oil olives: Results of a five-year project in central Italy. *Adv. Hortic. Sci.* 24(1), 78-90.
- Vogtländer, J.G., 2012. LCA: a practical guide for students, designers and business managers, 4 ed. Delft Academic Press (VSSD Publishers).
- Vogtländer, J.G., Bijma, A., Brezet, H.C., 2002. Communicating the eco-efficiency of products and services by means of the eco-costs/value model. *Journal of Cleaner Production* 10(1), 57-67.
- Von Alan, R.H., March, S.T., Park, J., Ram, S., 2004. Design science in information systems research. *Mis Quart* 28(1), 75-105.
- Walker, S., 1998. Experiments in sustainable product design. *Journal of Sustainable Product Design*, 42-53.
- Walls, J.G., Widmeyer, G.R., El Sawy, O.A., 1992. Building an information system design theory for vigilant EIS. *Information systems research* 3(1), 36-59.
- Waltemode, S., Mannweiler, C., Aurich, J.C., 2012. Life cycle oriented quality assessment of Technical Product-Service Systems, in: Dornfeld, D.A., Linke, B.S. (Eds.), 19th CIRP Conference on Life Cycle Engineering, LCE 2012. Springer Berlin Heidelberg, pp. 49-54.
- Wang, J., Lv, B., Yan, J., Li, Y., Li, Z., Chen, M., 2018. Ecological optimization design of silage equipment key components based on innovation method theory, in: Lu, C., Su, J., Pei, X. (Eds.), 6th International Forum on Industrial Design, IFID 2018. EDP Sciences.
- Wang, J., Rothausen, S.G.S.A., Conway, D., Zhang, L., Xiong, W., Holman, I.P., Li, Y., 2012. China's water-energy nexus: Greenhouse-gas emissions from groundwater use for agriculture. *Environmental Research Letters* 7(1).
- Weidema, B.P., 2005. The integration of economic and social aspects in life cycle impact assessment. *The International Journal of Life Cycle Assessment* 11(S1), 89-96.
- Wenzel, H., Hauschild, M.Z., Alting, L., 1997. Environmental assessment of products, Methodology, tools, techniques and case studies. Chapman & Hall, United Kingdom.
- Wever, R., Van Kuijk, J., Boks, C., 2008. User-centred design for sustainable behaviour. *International journal of sustainable engineering* 1(1), 9-20.
- Wiek, A., Binder, C.R., 2005. Solution spaces for decision-making—a sustainability assessment tool for city-regions. *Environmental impact assessment review* 25(6), 589-608.
- Wolfenson, K.D.M., 2013. Coping with the food and agriculture challenge: Smallholders' agenda. Food and Agriculture Organisation of the United Nations, Rome.
- Woltering, L., Fehlenberg, K., Gerard, B., Ubels, J., Cooley, L., 2019. Scaling – from “reaching many” to sustainable systems change at scale: A critical shift in mindset. *Agricultural Systems* 176.
- World Programme for the Census of Agriculture (WCA), 2010. A system of integrated agricultural census and surveys. FAO Statistical Development.
- Wrasse, K., Hayka, H., Stark, R., 2015. Simulation of product-service-systems piloting with agent-based models (outlined revision), in: Brissaud, D., Boucher, X. (Eds.), 7th CIRP Industrial Product-Service Systems Conference, IPSS 2015. Elsevier B.V., pp. 108-113.
- Xing, K., Ness, D., Lin, F.R., 2013a. A service innovation model for synergistic community transformation: Integrated application of systems theory and product-service systems. *Journal of Cleaner Production* 43, 93-102.
- Xing, K., Wang, H.F., Qian, W., 2013b. A sustainability-oriented multi-dimensional value assessment model for product-service development. *International Journal of Production Research* 51(19), 5908-5933.
- Xue, J.F., Pu, C., Liu, S.L., Zhao, X., Zhang, R., Chen, F., Xiao, X.P., Zhang, H.L., 2016. Carbon and nitrogen footprint of double rice production in Southern China. *Ecol Indic* 64, 249-257.
- Xue, X., Pang, Y., Landis, A.E., 2014. Evaluating agricultural management practices to improve the environmental footprint of corn-derived ethanol. *Renew. Energy* 66, 454-460.
- Yang, C.J., Chen, J.L., 2011. Accelerating preliminary eco-innovation design for products that integrates case-based reasoning and TRIZ method. *Journal of Cleaner Production* 19(9-10), 998-1006.

- Yang, K.X., Moore, P., Wong, C.-B., Pu, J.-S., Chong, S.K., Simon, M., 2004. A methodology for implementing product-service systems for consumer products, SusProNet Conference Information Product Service Systems: Practical Value. Brussels, Belgium, p. 78.
- Yang, X., Li, F., Wang, X., Wang, L., 2012. A green-feature based LCA backtracking mechanism, 2012 Electronics Goes Green 2012+. IEEE, pp. 1-6.
- Yang, X., Moore, P., Pu, J.S., Wong, C.B., 2009. A practical methodology for realizing product service systems for consumer products. *Computers and Industrial Engineering* 56(1), 224-235.
- Yaregal, E., 2014. Experience of rice value chain project in Amhara region. *Experience in Rice Mechanization*; Shiratori, K., Alemu, D., Kelemu, F., Eds, 1-16.
- Yixiang, Y., Zhenggang, L., Xiao, L., Chouyong, C., 2012. Study on development & design of product service system, 2nd International Conference on Advanced Design and Manufacturing Engineering, ADME 2012. Taiyuan, pp. 468-474.
- Zahn, F., Viaux, P., Vilain, L., Girardin, P., Mouchet, C., 2008. Assessing farm sustainability with the IDEA method—from the concept of agriculture sustainability to case studies on farms. *Sustainable development* 16(4), 271-281.
- Zhang, C., Anadon, L.D., 2014. A multi-regional input–output analysis of domestic virtual water trade and provincial water footprint in China. *Ecological Economics* 100, 159-172.
- Zhang, H., Haapala, K.R., Vanlue, M.E., Funk Ii, K.H., 2011. Environmental impact and cost assessment of product service systems using IDEFO modeling, 39th Annual North American Manufacturing Research Conference, NAMRC39. Corvallis, OR, pp. 172-181.
- Zhang, Z.F., Ostrosi, E., Fougères, A.J., Bluntzer, J.B., Liu, Y., Pfaender, F., Tzen, M.Z., 2014. City-product service system: A multi-scale intelligent engineering design approach, in: Curran, R., Xu, W., Chou, S.Y., Cha, J., Stjepandic, J. (Eds.), 21st ISPE Inc. International Conference on Concurrent Engineering: Moving Integrated Product Development to Service Clouds in the Global Economy, CE 2014. IOS Press BV, pp. 405-413.
- Zhen, L., Routray, J.K., 2003. Operational indicators for measuring agricultural sustainability in developing countries. *Environ Manage* 32(1), 34-46.
- Ziout, A., Azab, A., 2015. Industrial product service system: A case study from the agriculture sector. *Procedia CIRP* 33, 64-69.
- Zwolinski, P., Lopez-Ontiveros, M.-A., Brissaud, D., 2006. Integrated design of remanufacturable products based on product profiles. *Journal of Cleaner Production* 14(15-16), 1333-1345.